

Proportional pressure relief valve, pilot operated

RA 29160/04.05
Replaces: 06.98

1/10

Model DBE(M) and DBE(M)E

Sizes 10, 25 ¹⁾
Component series 5X
Maximum operating pressure 350 bar
Maximum flow 400 L/min

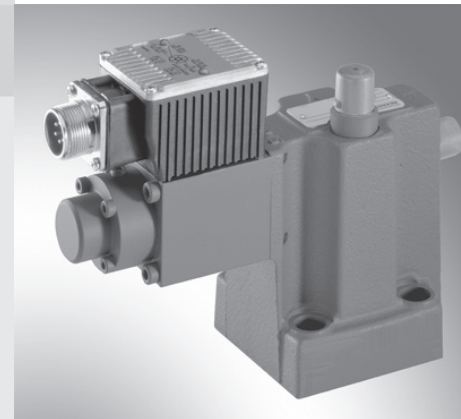

Table of contents

Contents	Page
Features	1
Ordering code	2
Preferred types	2
Symbols	2
Function, section	3
Technical data	4 and 5
Control electronics	5 and 6
Electrical connection, cable sockets	5
Characteristic curves	7
Unit dimensions	8 and 9

¹⁾ Size 32, component series 3X, see data sheet RE 29142

Features

- Pilot operated valve for limiting a system pressure
- Operation by proportional solenoid
- For subplate mounting:
 - Position of ports according to DIN 24340, form E
 - subplates according to data sheet RE 45064, (separate order, see pages 8 and 9)
- Optional maximum pressure relief function by means of spring-loaded pilot valve
- Valve and control electronics from a single source
- External control electronics for types DBE and DBEM:
 - Analogue amplifier type VT-VSPA1-1 in Euro-card format (separate order, see page 5)
 - Digital amplifier type VT-VSPD-1 in Euro-card format (separate order, see page 5)
 - Amplifier type VT 11131 of modular design (separate order, see page 5)
- Integrated electronics (OBE) with types DBEE and DBEME:
 - Low tolerances of the command value/pressure characteristic curve
 - Up and down ramps can be adjusted independently of each other

Ordering code

DBE	-5X/	G24	*
Proportional pressure relief valve Without maximum pressure relief function = No code With maximum pressure relief function = M For external control electronics = No code With integrated electronics (OBE) = E Size 10 = 10 Size 25 = 20 Component series 50 to 59 (50 to 59: unchanged installation and connection dimensions) = 5X Pressure stage up to 50 bar (725 PSI) = 50 up to 100 bar (1450 PSI) = 100 up to 200 bar (2900 PSI) = 200 up to 315 bar (4569 PSI) = 315 up to 350 bar (5075 PSI) = 350 External pilot oil drain = Y Unloading port X, external pilot oil drain = XY			Further details in clear text Seal material M = NBR seals, suitable for mineral oil (HL, HLP) to DIN 51524 V = FKM seals Electrical connection for DBE; DBEM: K4 = Without cable socket, with component plug to DIN EN 175301-803 Cable socket – separate order, see page 5 for DBEE; DBEME: K31 = Without cable socket, with component plug to DIN EN 175201-804 Cable socket – separate order, see page 5 Supply voltage of electronics G24 = 24 V DC

Standard types

Size 10

Type DBEME 10	Material no.
DBEME 10-5X/50YG24K31M	R900908585
DBEME 10-5X/100YG24K31M	R900954707
DBEME 10-5X/200YG24K31M	R900954708
DBEME 10-5X/315YG24K31M	R900536812
DBEME 10-5X/350YG24K31M	R900941261

Size 25

Type DBEME 20	Material no.
DBEME 20-5X/50YG24K31M	R900954711
DBEME 20-5X/100YG24K31M	R900937307
DBEME 20-5X/200YG24K31M	R900954709
DBEME 20-5X/315YG24K31M	R900536813
DBEME 20-5X/350YG24K31M	R900954710

Symbols

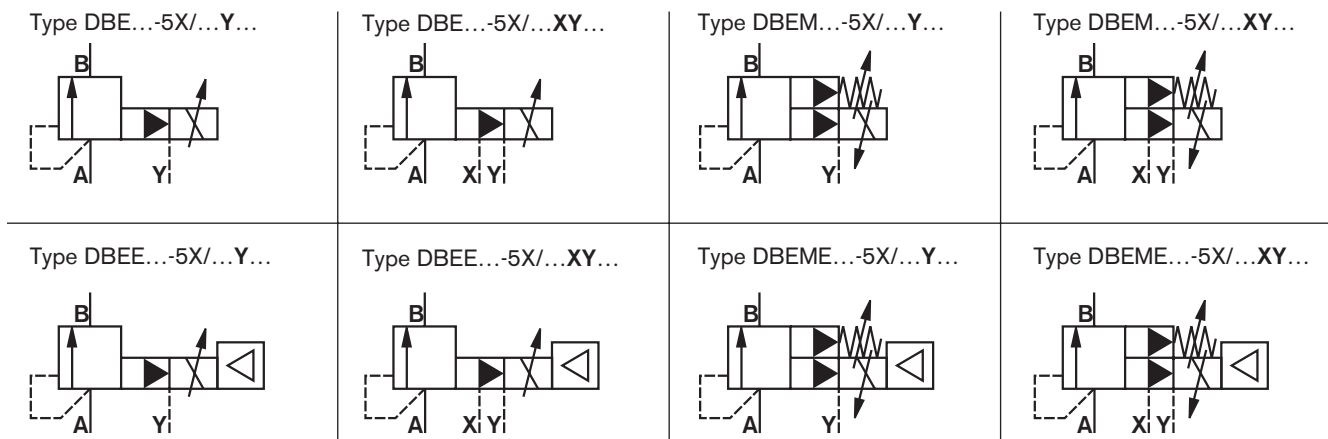

Function, section

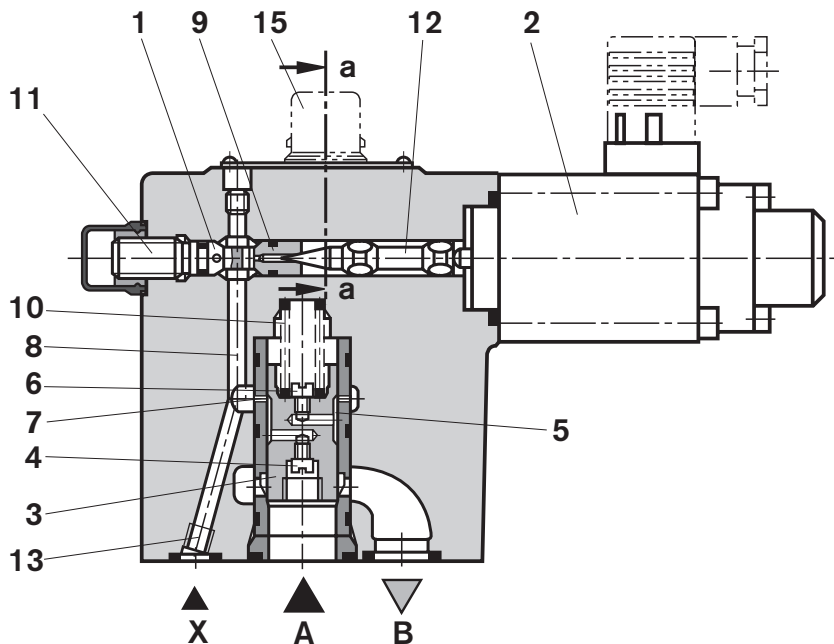

Type DBE...-5X/...XY...G24K4.

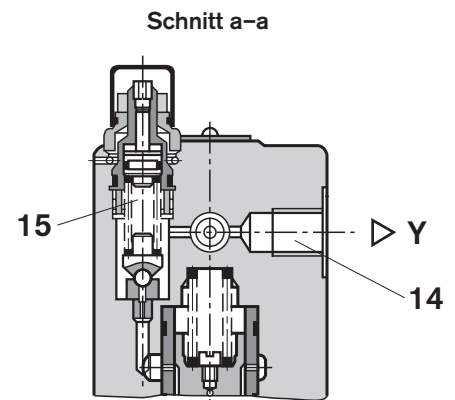

Type DBEM...-5X/...
with maximum pressure relief function

13 Version "XY" – with additional unloading port X

14 Port Y – external pilot oil drain, separate and at zero pressure to tank

Valves of types DBE and DBEM are pilot operated pressure relief valves. They are used to limit the pressure in hydraulic systems.

These valves can be used to infinitely adjust the pressure to be limited in relation to the electrical command value.

Basically, these valves consist of a pilot valve (1) installed in a common housing, with proportional solenoid (2) and the main spool insert (3).

Type DBE...

The pressure present in port A acts on the underside of the main spool (3). At the same time, the pressure is applied via orifice (4), ring channel (5) and orifice (6) to the spring loaded side of the main spool (3). The hydraulic force at the pilot poppet (12) acts via the radial bore (7), control bore (8) and orifice (9) against the command value-dependent force of the proportional solenoid (2). When the hydraulic force overcomes the solenoid force, the pilot poppet (12) opens. Due to this, pilot oil can drain via port Y (14) to the tank and causes a pressure differential across the orifice, which acts on the main spool (3) and lifts it against the force of the return spring (10). The connection of ports A to B is opened and there is no further pressure increase.

At port X (13) the valve may be unloaded or the maximum pressure limited.

Type DBEM...

Optionally the valve is available with an additional spring loaded pilot valve (15) for maximum pressure limitation (redundant pressure relief function).

We generally recommend the selection of this version! (When using these valves, observe the notes on page 4.)

Type DBEE and DBEME – with integrated electronics (OBE)

In terms of function and design, these valves are basically the same as types DBE and DBEM, except for the integrated electronics. The control electronics which is accommodated in housing (16) receives the supply and command value voltages via the cable socket (17).

The command value/pressure characteristic curve (zero point at valve seat (11) and gradient at I_{max} potentiometer (R30) in the control electronics) is factory-set with very low manufacturing tolerances.

The ramp times for pressure build-up and reduction can be set independently of each other using two potentiometers.

For further details regarding the integrated electronics, see pages 5 and 6.

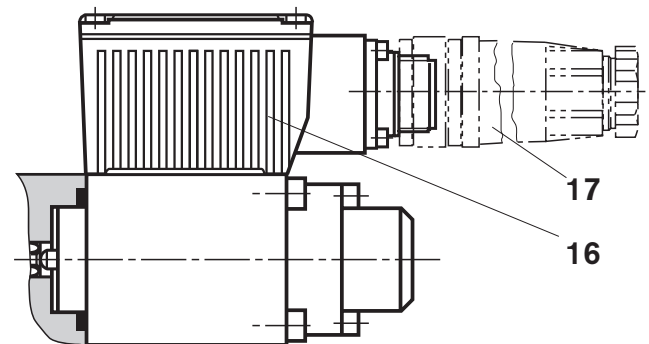

Type DBEE...-5X/...G24K31...

Technical data (for applications outside these parameters, please consult us!)**General**

Size		Size	10	25
Weight	- DBE and DBEM	kg (lb)	3.4	3.8
	- DBEE and DBEME	kg (lb)	3.5	3.9
Installation orientation			Optional	
Storage temperature range		°C (°F)	- 20 to + 80 (- 68 to + 176)	
Ambient temperature range	- DBE and DBEM	°C (°F)	- 20 to + 70 (- 68 to + 158)	
	- DBEE and DBEME	°C (°F)	- 20 to + 50 (- 68 to + 122)	
Hydraulic [measured with HLP 46 at 40°C ± 5°C (104°F ± 41°F)]				
Size		Size	10	25
Max. operating pressure	- Ports A, B and X	bar (PSI)	350	
	- Port Y		Separate and at zero pressure to tank	
Max. set pressure	- Pressure stage	bar (PSI)	50 (725)	
	- Pressure stage	bar (PSI)	100 (1450)	
	- Pressure stage	bar (PSI)	200 (2900)	
	- Pressure stage	bar (PSI)	315 (4569)	
	- Pressure stage	bar (PSI)	350 (5076)	
Min. set pressure at zero command value		bar (PSI)	See characteristic curve on page 7	
Maximum pressure relief function (infinitely adjustable)			Pressure adjustment range:	Factory setting:
	- Pressure stage	bar (PSI)	30 to 70 (435 to 1015)	to 70 bar (1015)
	- Pressure stage	bar (PSI)	50 to 130 (725 to 1886)	to 130 bar (1886)
	- Pressure stage	bar (PSI)	90 to 230 (1305 to 3336)	to 230 bar ()
	- Pressure stage	bar (PSI)	150 to 350 (2176 to 5076)	to 350 bar ()
	- Pressure stage	bar (PSI)	200 to 390 (2901 to 5657)	to 390 bar ()
Max. flow		L/min (GPM)	200 (52.83)	400 (105.67)
Pilot oil flow		L/min (GPM)	0.5 to 1.8 (0.13 to 0.47)	0.5 to 2.1 (0.13 to 0.55)
Hydraulic fluid			Mineral oil (HL, HLP) to DIN 51524 Other hydraulic fluids on enquiry!	
Hydraulic fluid temperature range		°C (°F)	- 20 to + 80	
Viscosity range		mm ² /s (SUS)	15 to 380	
Max. permissible degree of contamination of the hydraulic fluid - cleanliness class to ISO 4406 (c)			Class 20/18/15 ¹⁾	
Hysteresis (see command value/pressure characteristic curve)		%	± 1.5 of max. set pressure	
Repeatability		%	< ± 2 of max. set pressure	
Linearity		%	± 3.5 of max. set pressure	
Tolerance of the command value/pressure curve, referred to the hysteresis curve, increasing pressure	- DBE and DBEM	%	± 2.5 of max. set pressure	
	- DBEE and DBEME	%	± 1.5 of max. set pressure	
Step response $T_u + T_g$	0 % → 100 %	ms	150 depends on flow and on the line volume (A) of the system	
	100 % → 0 %	ms		

¹⁾ The cleanliness classes specified for components must be adhered to in hydraulic systems. Effective filtration prevents malfunction and, at the same time, increases the service life of components.

For the selection of filters, see data sheets RE 50070, RE 50076, RE 50081, RE 50086 and RE 50088.

Technical data (for applications outside these parameters, please consult us!)

Electrical

Supply voltage	V	24 DC
Min. control current	mA	100
Max. control current	– DBE and DBEM	mA 1600
	– DBEE and DBEME	mA 1440 to 1760
Coil resistance	– Cold value at 20° C	Ω 5.4
	– Max. hot value	Ω 7.8
Duty cycle	%	100
Electrical connection	– DBE and DBEM	With component plug to DIN EN 175301-803 Cable socket to DIN EN 175301-803 ¹⁾
	– DBEE and DBEME	With component plug to DIN EN 175201-804 Cable socket to DIN EN 175201-804 ¹⁾
Type of protection of the valve to EN 60529		IP 65 with cable socket mounted and locked

Control electronics

– For DBEE and DBEME		Integrated in the valve, see page 6
– For DBE and DBEM		
Amplifier in Euro-card format (separate order)	analogue	VT-VSPA1-1 according to data sheet RE 30111
	digital	VT-VSPD-1 according to data sheet RE 30523
Amplifier of modular design (separate order)	analogue	VT 11131 according to data sheet RE 29865

¹⁾ Separate order, see below

Note: For details regarding **environment simulation testing** in the fields of EMC (electromagnetic compatibility), climate and mechanical stress, see RE 29160-U (declaration on environmental compatibility).

Electrical connection, cable sockets (nominal dimensions in mm)

For types DBE and DBEM – for external control electronics

Cable socket to DIN EN 175301-803

Separate order: Material no. **R901017011**

Connection to component plug

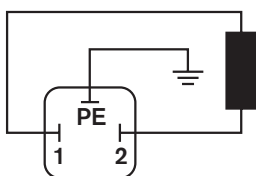

Connection to cable socket

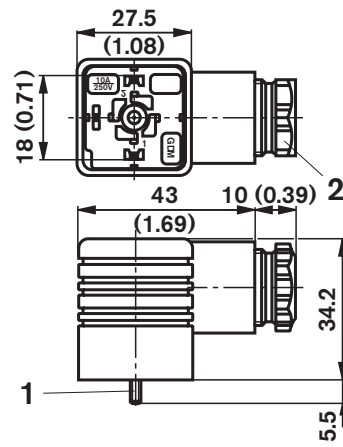
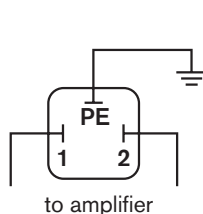

1 Fixing screw M3
Tightening torque $M_T = 0.5 \text{ Nm}$

For types DBEE and DBEME – with integrated electronics (OBE)

Cable socket to DIN EN 175201-804

Separate order: Material no. **R900021267** (version made of plastic)

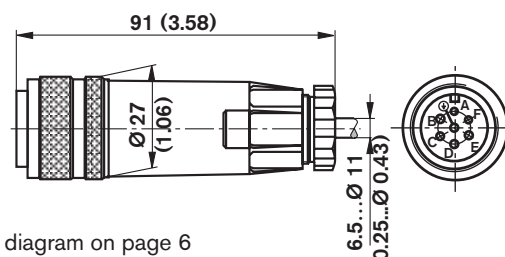

For the pin assignment, see block circuit diagram on page 6

Integrated electronics for types DBEE and DBEME

Function

The integrated electronics is controlled via the two differential amplifier connections D and E.

The ramp generator generates from a command value step change (0 to 10 V or 10 to 0 V) a delayed rise or drop in the solenoid current. The rise time can be adjusted by means of potentiometer R14, the drop time by means of potentiometer R13.

The maximum ramp time of 5 s is only possible over the entire command value range. With smaller command value changes the ramp time shortens accordingly.

The command value/solenoid current characteristic curve is matched to the valve by the characteristic curve generator, so that non-linearities in the hydraulics can be compensated for and hence a linear command value/pressure characteristic curve is obtained.

The current regulator controls the solenoid current independ-

ently of the solenoid coil resistance.

The gradient of the command value/current characteristic curve, and hence also the gradient of the command value/pressure characteristic curve of the proportional pressure valve may be altered using potentiometer R30.

Potentiometer R43 is used to adjust the biasing current. This setting should not be altered. If necessary, the zero point of the command value/pressure characteristic curve can be adjusted at the valve seat.

The power stage of the electronics for controlling the proportional solenoid is a chopper amplifier. It is pulse-width-modulated with a clock frequency of 300 Hz.

The solenoid current can be measured at the two measurement sockets MP1 and MP2. A voltage drop of 0.352 V at the measurement resistor corresponds to a solenoid current of 1.6 A.

Block circuit diagram / pin assignment of integrated electronics

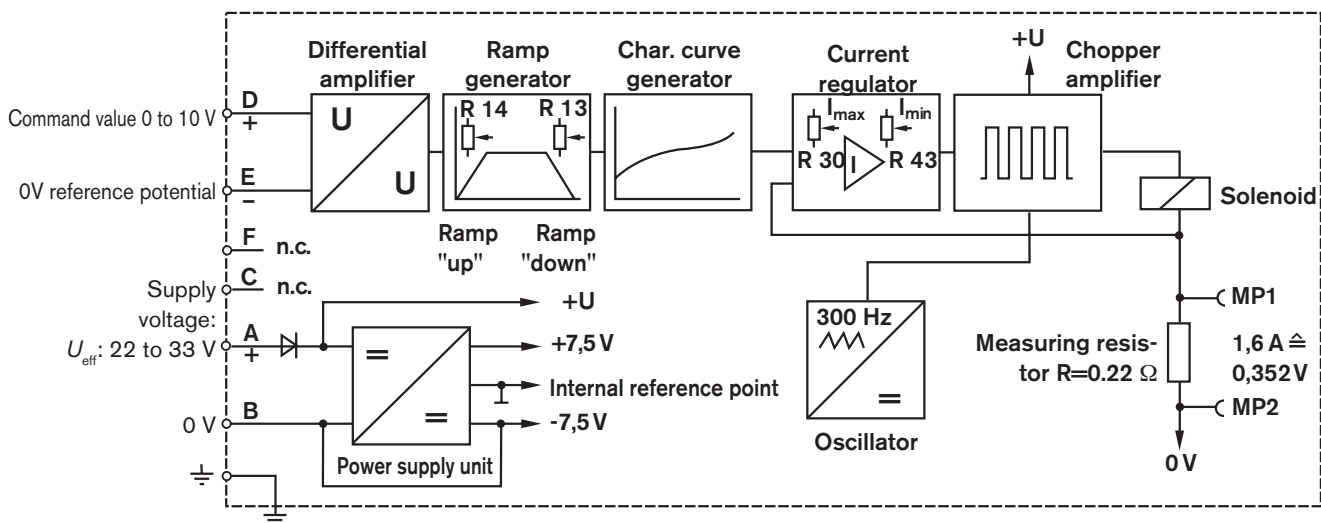

Supply voltage

Power supply unit with rectifier

Single phase rectification or three phase bridge: $U_{eff} = 22$ to 33 V

Residual ripple content at power supply unit: $< 5\%$

Output current: $I_{eff} = \text{max. } 1.4$ A

- Supply cable:
- Recommended: 5-core 0.75 or 1 mm² with PE conductor and shield
 - Outside diameter 6.5 to 11 mm
 - Shield to 0 V supply voltage
 - Max. permissible length 100 m

The minimum supply voltage of the power supply unit depends on the length of the supply cable (see diagram).

For lengths > 50 m a capacitor of 2200 μ F must be installed near the valve in the supply line.

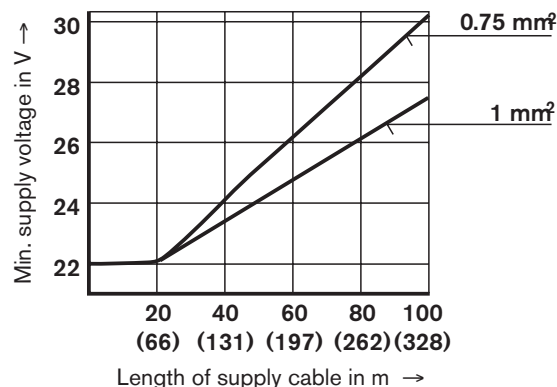

Characteristic curves - measured with HLP-46, $\vartheta_{oil} = 40^{\circ}\text{C} \pm 5^{\circ}\text{C}$ ($104^{\circ}\text{F} \pm 41^{\circ}\text{F}$)

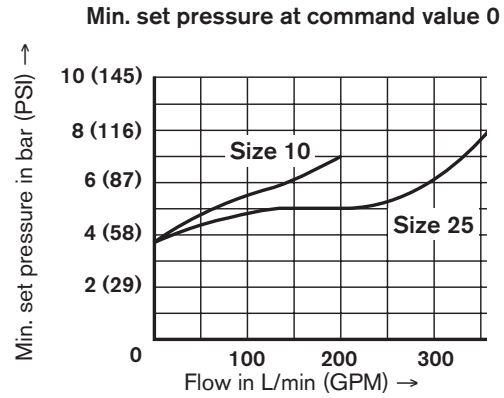
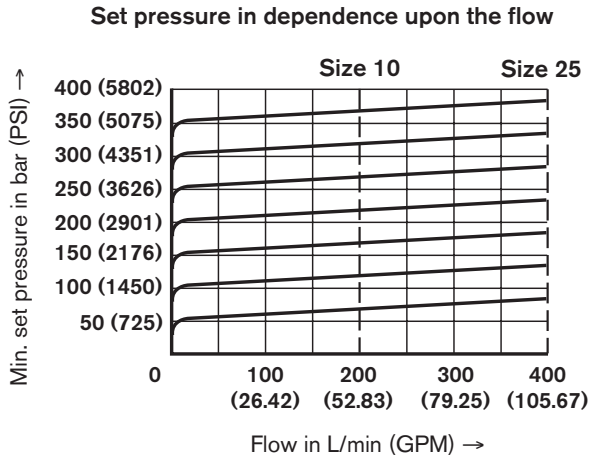

The characteristic curves are valid for an outlet pressure in $B = 0$ bar over the entire flow range.

Note: In order that the min. set pressure can be achieved, the biasing current must not exceed 100 mA.

Command value/pressure characteristic curves
(measured at a flow of 27 L/min)

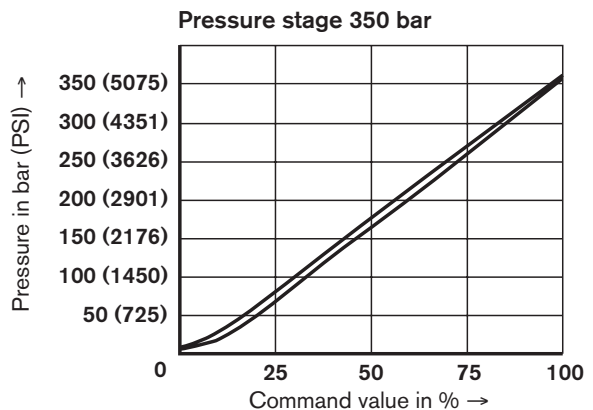
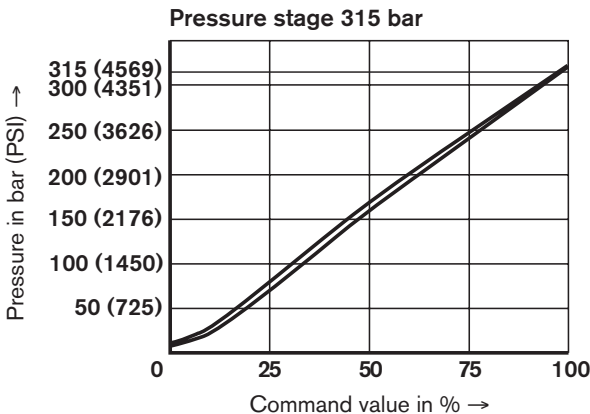
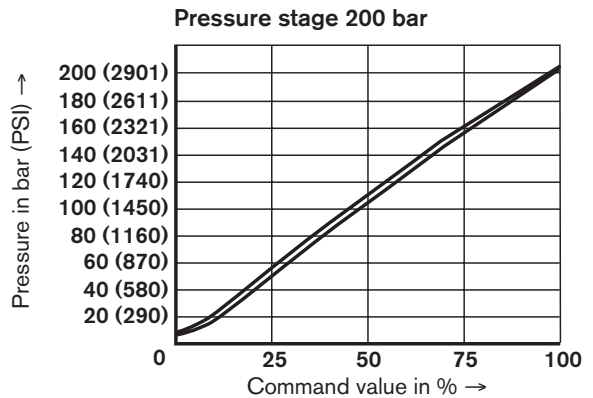
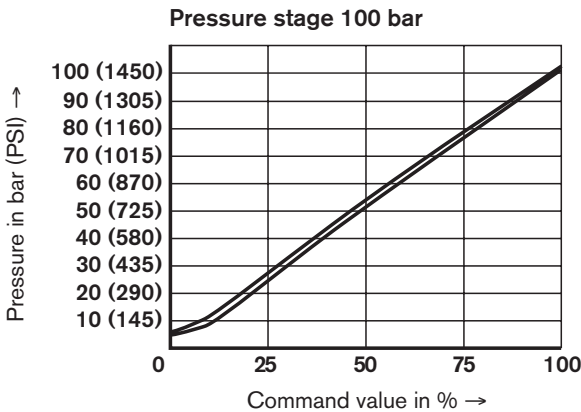
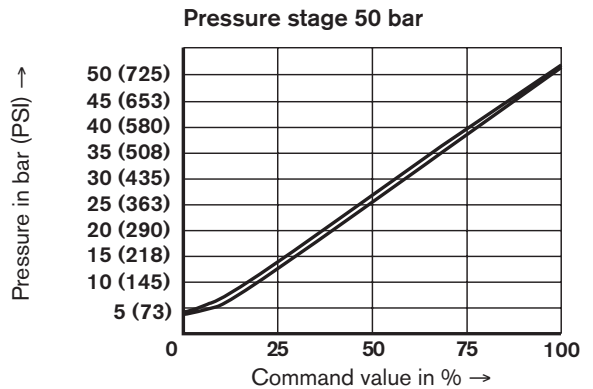

Unit dimensions: Size 10 - nominal dimensions in mm (inches)

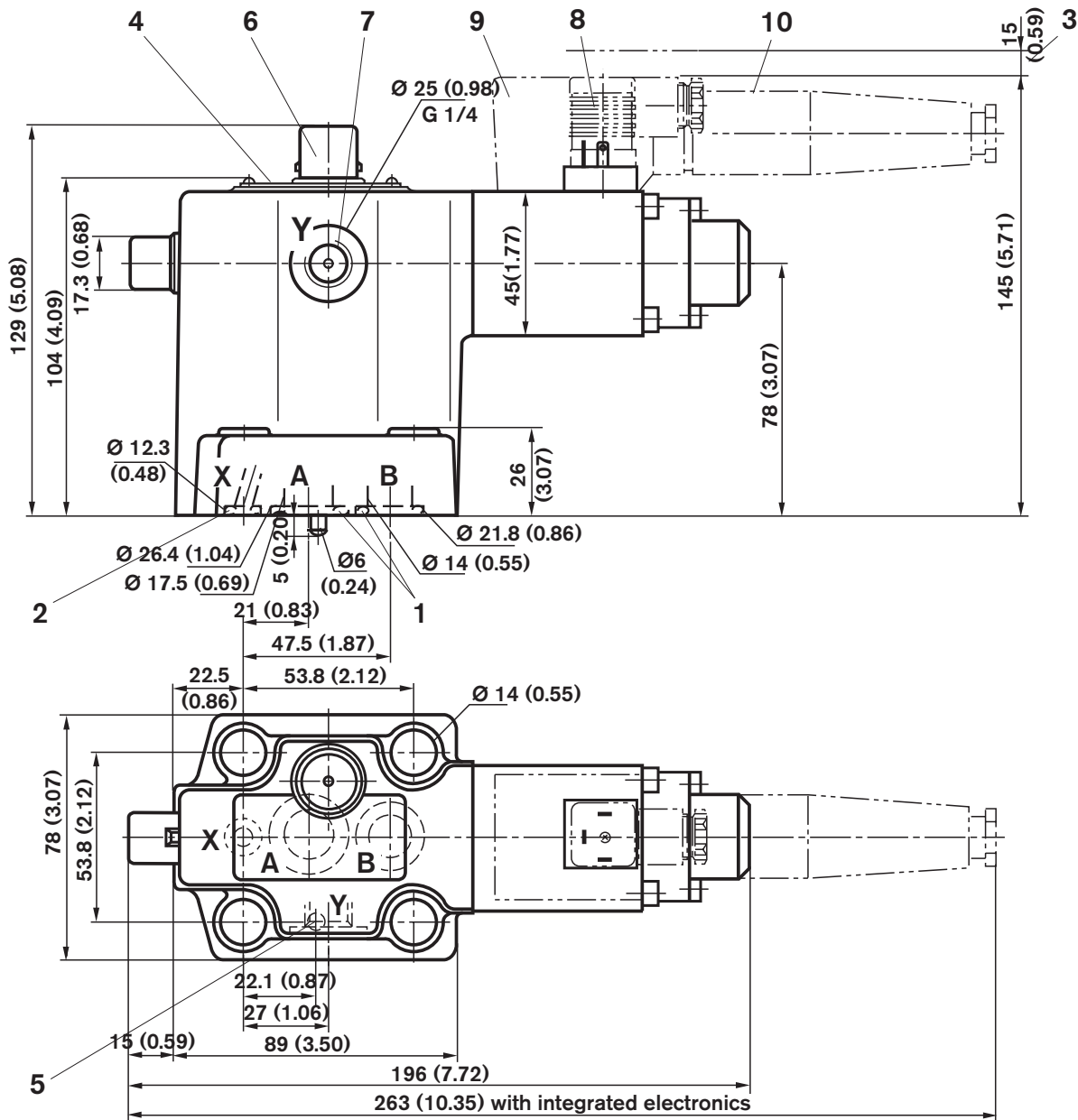

- 1 Different seal rings for ports A and B
- 2 Seal ring for port X
- 3 Space required to remove cable socket
- 4 Nameplate
- 5 Locating pin
- 6 Maximum pressure relief function (types DBEM, DBEME)
When using these valves, observe the notes on page 4!
- 7 External pilot oil drain,
separate and at zero pressure to tank
- 8 Cable socket for type DBE(M)
(separate order, see page 5).
- 9 Integrated electronics (OBE)
- 10 Cable socket for type DBE(M)E
(separate order, see page 5).

Required surface quality of the mating part

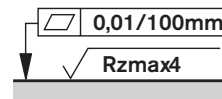

Tolerances to: – General tolerances ISO 2768-mK
– Tolerancing principle ISO 8015

Subplates to data sheet RE 45064 and valve fixing screws must be ordered separately.

Subplates: G 545/01, G 3/8 (SAE-6; 9/16-18)
G 546/01, G 1/2 (SAE-8; 3/4-16)

Valve fixing screws:

4 socket head cap screws M12 x 50 DIN 912-10.9
(1/2-13 UNC x 2")

Tightening torque $M_T = 70 \text{ Nm}$ (51.63 lb-ft)

Unit dimensions: Size 25 - nominal dimensions in mm (inches)

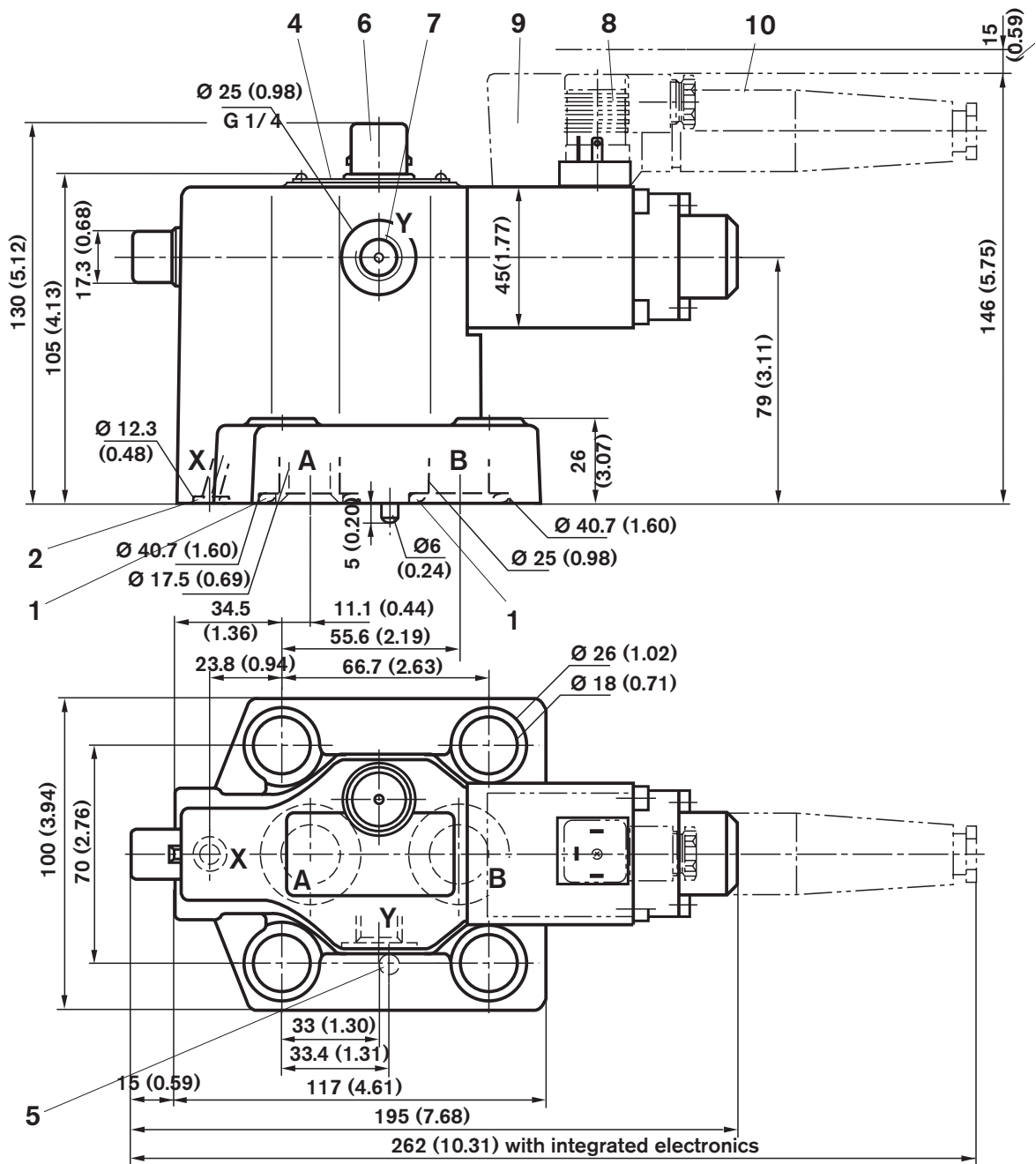

- 1 Identical seal rings for ports A and B
- 2 Seal ring for port X
- 3 Space required to remove cable socket
- 4 Nameplate
- 5 Locating pin
- 6 Maximum pressure relief function (types DBEM, DBEME)
When using these valves, observe the notes on page 4!
- 7 External pilot oil drain, separate and at zero pressure to tank
- 8 Cable socket for type DBE(M)
(separate order, see page 5)
- 9 Integrated control electronics
- 10 Cable socket for type DBE(M)E
(separate order, see page 5)

Required surface quality of the mating part

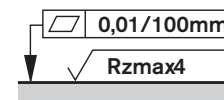

Tolerances to: – General tolerances ISO 2768-mK
– Tolerancing principle ISO 8015

Subplates to data sheet RE 45064 and valve fixing screws must be ordered separately.

Subplates: G 408/01, G 3/4 (SAE-12; 1-1/16-12)
G 409/01, G 1 (SAE-16; 1-5/16-20)

Valve fixing screws:

4 socket head cap screws M16 x 50 DIN 912-10.9
(5/8-11 UNC x 2")

Tightening torque $M_T = 150 \text{ Nm}$ (110.63 lb-ft)

Notes

Bosch Rexroth Corp.
Industrial Hydraulics
2315 City Line Road
Bethlehem, PA 18017-2131
USA
Telephone (610) 694-8300
Facsimile (610) 694-8467
www.boschrexroth-us.com

© 2004 Bosch Rexroth Corporation

All rights reserved. Neither this document nor any part of it may be reproduced, duplicated, circulated or disseminated, whether by copy, electronic format or any other means, without the prior consent and authorization of Bosch Rexroth Corporation.

The data and illustrations in this brochure/data sheet are intended only to describe or depict the products. No representation or warranty, either express or implied, relating to merchantability or fitness for intended use, is given or intended by virtue of the information contained in this brochure/data sheet. The information contained in this brochure/data sheet in no way relieves the user of its obligation to insure the proper use of the products for a specific use or application. All products contained in this brochure/data sheet are subject to normal wear and tear from usage.

Subject to change.

Notes

Bosch Rexroth Corp.
Industrial Hydraulics
2315 City Line Road
Bethlehem, PA 18017-2131
USA
Telephone (610) 694-8300
Facsimile (610) 694-8467
www.boschrexroth-us.com

© 2004 Bosch Rexroth Corporation

All rights reserved. Neither this document nor any part of it may be reproduced, duplicated, circulated or disseminated, whether by copy, electronic format or any other means, without the prior consent and authorization of Bosch Rexroth Corporation.

The data and illustrations in this brochure/data sheet are intended only to describe or depict the products. No representation or warranty, either express or implied, relating to merchantability or fitness for intended use, is given or intended by virtue of the information contained in this brochure/data sheet. The information contained in this brochure/data sheet in no way relieves the user of its obligation to insure the proper use of the products for a specific use or application. All products contained in this brochure/data sheet are subject to normal wear and tear from usage.

Subject to change.

Notes

Bosch Rexroth Corp.
Industrial Hydraulics
2315 City Line Road
Bethlehem, PA 18017-2131
USA
Telephone (610) 694-8300
Facsimile (610) 694-8467
www.boschrexroth-us.com

© 2004 Bosch Rexroth Corporation

All rights reserved. Neither this document nor any part of it may be reproduced, duplicated, circulated or disseminated, whether by copy, electronic format or any other means, without the prior consent and authorization of Bosch Rexroth Corporation.

The data and illustrations in this brochure/data sheet are intended only to describe or depict the products. No representation or warranty, either express or implied, relating to merchantability or fitness for intended use, is given or intended by virtue of the information contained in this brochure/data sheet. The information contained in this brochure/data sheet in no way relieves the user of its obligation to insure the proper use of the products for a specific use or application. All products contained in this brochure/data sheet are subject to normal wear and tear from usage.

Subject to change.