

A200P

Advanced™ Series **PLASTIC** Pumps

EOM

Engineering
Operation &
Maintenance

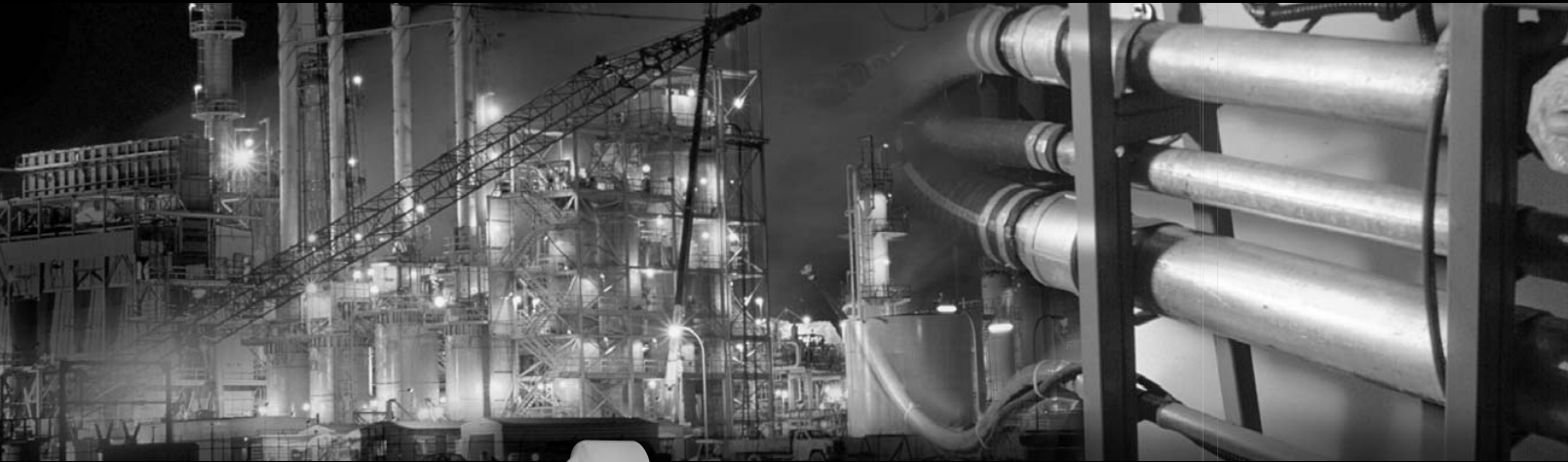

Simplify your process

airpumping.co.uk

of 1979
Unit 16, Upminster Trading Park, Wanley St., Upminster, Essex, RM14 3PJ, ENGLAND

WILDEN®

A **DOVER** COMPANY

ACCU-FLO™
SOLENOID PUMP TECHNOLOGY



WIL-11060-E-03
REPLACES WIL-11060-E-02

TABLE OF CONTENTS

SECTION 1 CAUTIONS—READ FIRST!1

SECTION 2 WILDEN PUMP DESIGNATION SYSTEM2

SECTION 3 HOW IT WORKS—PUMP & AIR DISTRIBUTION SYSTEM3

SECTION 4 DIMENSIONAL DRAWINGS4

SECTION 5 PERFORMANCE

 A. A200P Performance Curves

 Rubber-Fitted5

 PTFE-Fitted5

 B. Suction Lift Curves6

SECTION 6 SUGGESTED INSTALLATION, OPERATION & TROUBLESHOOTING7

SECTION 7 EXPLODED VIEW AND PARTS LISTING

 A200P Advanced™ Plastic

 Rubber-Fitted12

 PTFE-Fitted14

SECTION 8 ELASTOMER OPTIONS16



CAUTIONS — READ FIRST!



TEMPERATURE LIMITS*

Wetted Path

Polypropylene (PP) 0°C to 79.4°C 32°F to 175°F
 Polyvinylidene fluoride (PVDF)

-12.2°C to 107.2°C 10°F to 225°F

PTFE PFA -28.9°C to 87.8°C -20°F to 190°F

Elastomers

Neoprene -17.8°C to 93.3°C 0°F to 200°F

Buna-N -12.2°C to 82.2°C 10°F to 180°F

EPDM -51.1°C to 137.8°C -60°F to 280°F

Viton® -40°C to 176.7°C -40°F to 350°F

Wil-Flex™ -40°C to 107.2°C -40°F to 225°F

Polyurethane 12.2°C to 65.6°C 10°F to 150°F

Tetra-Flex™ PTFE w/Neoprene

4.4°C to 107.2°C 40°F to 225°F

Tetra-Flex™ PTFE w/EPDM

-10°C to 137°C 14°F to 280°F

Polytetrafluoroethylene (PTFE)

4.4°C to 104.4°C 40°F to 220°F

*Elastomer choice may change temperature limits



CAUTION: When choosing pump materials, be sure to check the temperature limits for all wetted components. Example: Viton® has a maximum limit of 176.7°C (350°F) but polypropylene has a maximum limit of only 79.4°C (175°F).



CAUTION: Maximum temperature limits are based upon mechanical stress only. Certain chemicals will significantly reduce maximum safe operating temperatures. Consult engineering guide for chemical compatibility and temperature limits.



CAUTION: Always wear safety glasses when operating pump. If diaphragm rupture occurs, material being pumped may be forced out air exhaust.



WARNING: Prevention of static sparking — If static sparking occurs, fire or explosion could result. Proper grounding of pump, valves, and containers is critical when handling flammable fluids or whenever discharge of static electricity is a hazard.



NOTE: Do not exceed 5.2 bar (75 psig) air supply for PFA pumps.



CAUTION: Do not exceed 8.6 bar (125 psig) air supply on polypropylene and PVDF pumps.



CAUTION: Advanced™ series plastic pumps are made with plastic that is not UV stabilized. Direct sunlight for prolonged periods can cause deterioration of plastics.



CAUTION: Before any maintenance or repair is attempted, the compressed air line to the pump should be disconnected and all air pressure allowed to bleed from pump. Disconnect all intake, discharge and air lines. Drain the pump by turning it upside down and allowing any fluid to flow into a suitable container.



CAUTION: Blow out air line for 10 to 20 seconds before attaching to pump to make sure all pipe line debris is clear. Use an in-line air filter. A 5µ (micron) air filter is recommended.



NOTE: Tighten all bolts prior to installation. Fittings may loosen during transportation.



NOTE: When installing polytetrafluoroethylene (PTFE) diaphragms, it is important to tighten outer pistons simultaneously (turning in opposite directions) to ensure tight fit.



CAUTION: Verify the chemical compatibility of the process and cleaning fluid to the pump's component materials in the Chemical Resistance Guide (see E4).



CAUTION: When removing the end cap using compressed air, the air valve end cap may come out with considerable force. Hand protection such as a padded glove or rag should be used to capture the end cap.



CAUTION: Do not over-tighten the air inlet reducer bushing. Additionally, too much torque on the muffler may damage the air valve muffler plate. Do not exceed 0.9 N·m (8 in-lbs).



CAUTION: Only explosion proof (NEMA 7) solenoid valves should be used in areas where explosion proof equipment is required.



CAUTION: Do not lubricate lube-free pumps.



CAUTION: The A200P pump is not submersible.



NOTE: When reinstalling the outer pistons, apply two (2) drops of Loctite® 246 to the shaft internal threads before the diaphragm assembly.

WILDEN PUMP DESIGNATION SYSTEM

**A200 ADVANCED™
PLASTIC**

**25 mm (1") Pump
Maximum Flow Rate:
170 LPM (45 GPM)**

**Maximum Operating
Pressure for PFA
is 5.2 bar (75 psig)**

LEGEND

A200P / XXXXX / XXX / XX / XXX / XXXX

MODEL

WETTED PARTS & OUTER PISTON
CENTER SECTION
AIR VALVE

DIAPHRAGMS

VALVE BALLS

O-RINGS
VALVE SEAT

SPECIALTY
CODE
(if applicable)

MATERIAL CODES

WETTED PARTS & OUTER PISTON

KK = PVDF / PVDF
PK = POLYPROPYLENE / PVDF
TT = PTFE / PTFE

CENTER SECTION

PP = POLYPROPYLENE

AIR VALVE

P = POLYPROPYLENE

DIAPHRAGMS

BNS = BUNA-N (Red Dot)
EPS = EPDM (Blue Dot)
FSS = SANIFLEX™
[Hytre® (Cream)]
NES = NEOPRENE (Green Dot)
PUS = POLYURETHANE (Clear)
TEU = PTFE W/EPDM
BACK-UP (White)
TNU = PTFE W/NEOPRENE
BACK-UP (White)
TSU = PTFE W/SANIFLEX™
BACK-UP (White)
VTS = VITON® (White Dot)
WFS = WIL-FLEX™ [Santoprene®
(Orange Dot)]

VALVE BALL

BN = BUNA-N (Red Dot)
EP = EPDM (Blue Dot)
FS = SANIFLEX™
[Hytre® (Cream)]
NE = NEOPRENE (Green Dot)
PU = POLYURETHANE (Brown)
TF = PTFE (White)
VT = VITON® (White Dot)
WF = WIL-FLEX™ [Santoprene®
(Orange Dot)]

VALVE SEAT

K = PVDF
P = POLYPROPYLENE
T = PTFE PFA

VALVE SEAT O-RING

BN = BUNA-N
PU = POLYURETHANE (Brown)
TV = PTFE ENCAP. VITON®
WF = WIL-FLEX™ (Santoprene®)

SPECIALTY CODES

- 0150 Accu-Flo™, 24V DC coil
- 0151 Accu-Flo™, 24V AC / 12V DC coil
- 0167 Accu-Flo™, 24V AC / 12V DC coil,
Wil-Gard II™ 110V
- 0180 Accu-Flo™, 24V AC / 12V DC coil, PFA coated
- 0360 Accu-Flo™, 24V DC coil, DIN flange

NOTE: MOST ELASTOMERIC MATERIALS USE COLORED DOTS FOR IDENTIFICATION.

Viton® is a registered trademark of DuPont Dow Elastomers.

HOW IT WORKS—PUMP

The Wilden diaphragm pump is an air-operated, positive displacement, self-priming pump. These drawings show flow pattern through the pump upon its initial stroke. It is assumed the pump has no fluid in it prior to its initial stroke.

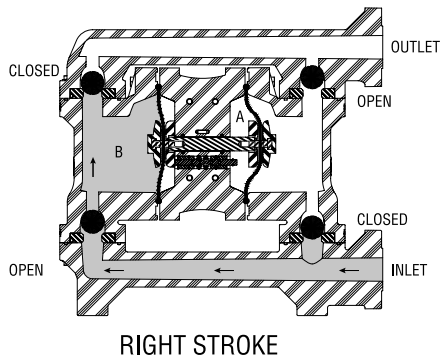

RIGHT STROKE

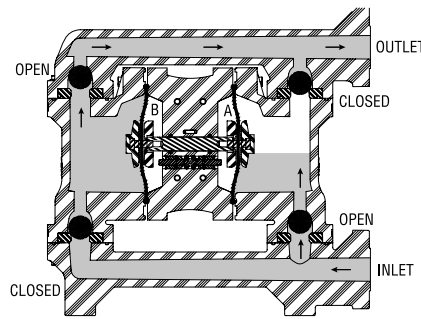

MID STROKE

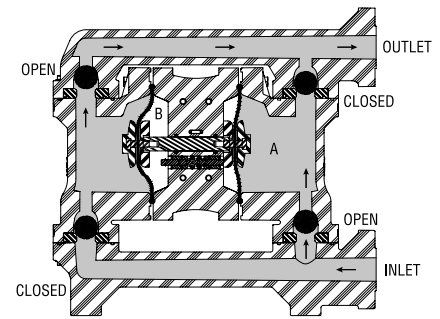

LEFT STROKE

FIGURE 1 The air valve directs pressurized air to the back side of diaphragm A. The compressed air is applied directly to the liquid column separated by elastomeric diaphragms. The diaphragm acts as a separation membrane between the compressed air and liquid, balancing the load and removing mechanical stress from the diaphragm. The compressed air moves the diaphragm away from the center block of the pump. The opposite diaphragm is pulled in by the shaft connected to the pressurized diaphragm. Diaphragm B is on its suction stroke; air behind the diaphragm has been forced out to the atmosphere through the exhaust port of the pump. The movement of diaphragm B toward the center block of the pump creates a vacuum within chamber B. Atmospheric pressure forces fluid into the inlet manifold forcing the inlet valve ball off its seat. Liquid is free to move past the inlet valve ball and fill the liquid chamber (see shaded area).

FIGURE 2 When the pressurized diaphragm, diaphragm A, reaches the limit of its discharge stroke, the air valve redirects pressurized air to the back side of diaphragm B. The pressurized air forces diaphragm B away from the center block while pulling diaphragm A to the center block. Diaphragm B is now on its discharge stroke. Diaphragm B forces the inlet valve ball onto its seat due to the hydraulic forces developed in the liquid chamber and manifold of the pump. These same hydraulic forces lift the discharge valve ball off its seat, while the opposite discharge valve ball is forced onto its seat, forcing fluid to flow through the pump discharge. The movement of diaphragm A toward the center block of the pump creates a vacuum within liquid chamber A. Atmospheric pressure forces fluid into the inlet manifold of the pump. The inlet valve ball is forced off its seat allowing the fluid being pumped to fill the liquid chamber.

FIGURE 3 At completion of the stroke, the air valve again redirects air to the back side of diaphragm A, which starts diaphragm B on its exhaust stroke. As the pump reaches its original starting point, each diaphragm has gone through one exhaust and one discharge stroke. This constitutes one complete pumping cycle. The pump may take several cycles to completely prime depending on the conditions of the application.

HOW IT WORKS—AIR DISTRIBUTION SYSTEM

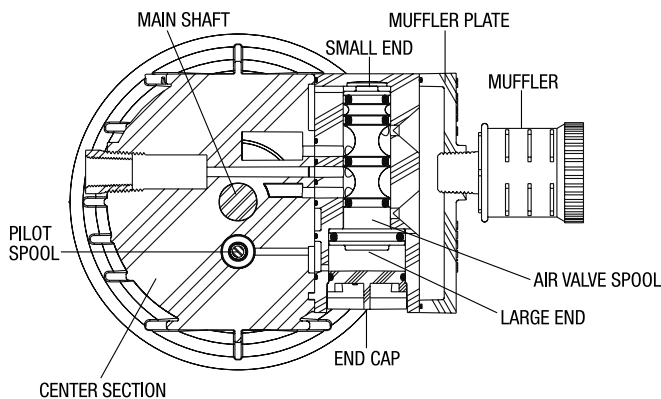

The Pro-Flo® patented air distribution system incorporates three moving parts: the air valve spool, the pilot spool, and the main shaft/diaphragm assembly. The heart of the system is the air valve spool and air valve. As shown in Figure A, this valve design incorporates an unbalanced spool. The smaller end of the spool is pressurized continuously, while the large end is alternately pressurized then exhausted to move the spool. The spool directs pressurized air to one air chamber while exhausting the other. The air causes the main shaft/diaphragm assembly to shift to one side — discharging liquid on that side and pulling liquid in on the other side. When the shaft reaches the end of its stroke, the inner piston actuates the pilot spool, which pressurizes and exhausts the large end of the air valve spool. The repositioning of the air valve spool routes the air to the other air chamber.

DIMENSIONAL DRAWINGS

A200P Advanced™ Plastic

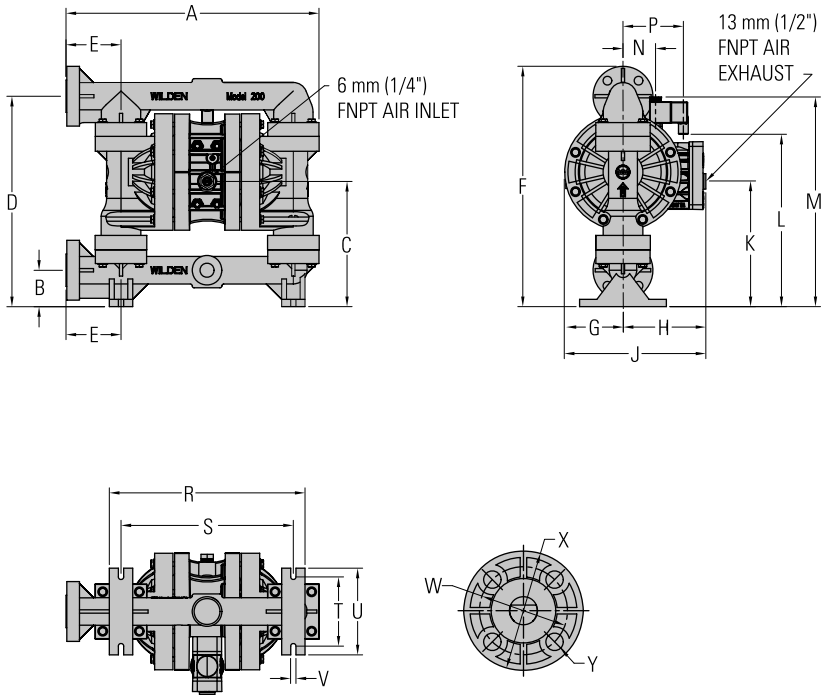

DIMENSIONS

ITEM	METRIC (mm)	STANDARD (inch)
A	457	18.0
B	66	2.6
C	259	10.2
D	381	15.0
E	99	3.9
F	434	17.1
G	104	4.1
H	150	5.9
J	257	10.1
K	226	8.9
L	310	12.2
M	378	14.9
N	58	2.3
P	109	4.3
R	353	13.9
S	310	12.2
T	124	4.9
U	157	6.2
V	10	0.4
	DIN (mm)	ANSI (inch)
W	85 DIA.	3.1 DIA.
X	115 DIA.	4.3 DIA.
Y	14 DIA.	0.6 DIA.

A200B Advanced™ Plastic

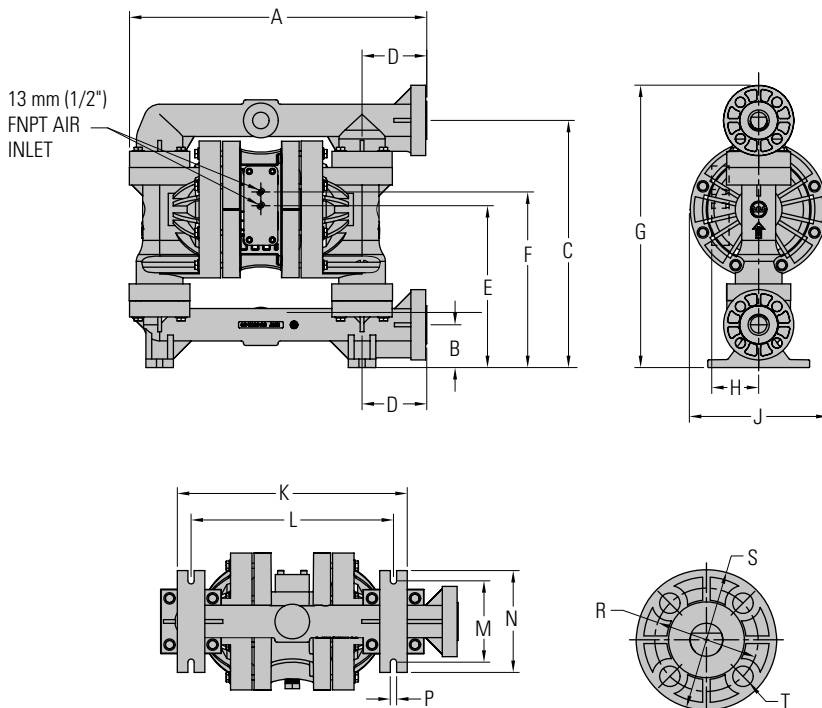

DIMENSIONS

ITEM	METRIC (mm)	STANDARD (inch)
A	457	18.0
B	66	2.6
C	381	15.0
D	99	3.9
E	249	9.8
F	269	10.6
G	434	17.1
H	71	2.8
J	213	8.4
K	353	13.9
L	310	12.2
M	124	4.9
N	157	6.2
P	10	0.4
	DIN (mm)	ANSI (inch)
W	85 DIA.	3.1 DIA.
X	115 DIA.	4.3 DIA.
Y	14 DIA.	0.6 DIA.

**A200P
RUBBER-FITTED**

Height 434 mm (17.1")
 Width 457 mm (18.0")
 Depth 257 mm (10.1")
 Est. Ship Weight.....
 Polypropylene 14 kg (31 lbs)
 PVDF 19 kg (41 lbs)
 Air Inlet 6 mm (1/4")
 Inlet 25 mm (1")
 Outlet 25 mm (1")
 Suction Lift 4.8 m Dry (15.9')
 9.3 m Wet (30.6')
 Displacement/Stroke 0.34 l (0.09 gal.)¹
 Max. Flow Rate 170 lpm (45 gpm)
 Max. Size Solids..... 4.8 mm (3/16")

¹Displacement per stroke was calculated at 4.8 bar (70 psig) air inlet pressure against a 2 bar (30 psig) head pressure

Example: To pump 75.7 lpm (20 gpm) against a discharge pressure head of 3.4 bar (50 psig) requires 5.5 bar (80 psig) and 34 Nm³/h (20 scfm) air consumption

Caution: Do not exceed 8.6 bar (125 psig) air supply pressure.

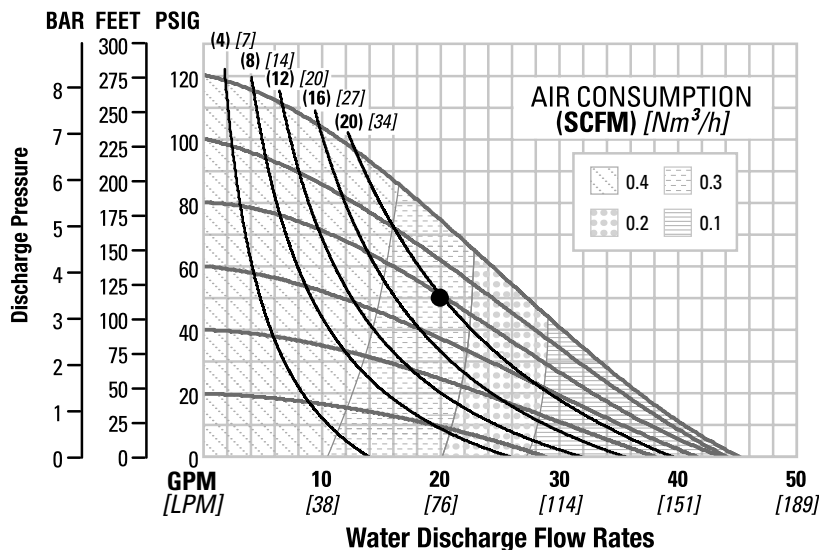

Flow rates indicated on chart were determined by pumping water.

For optimum life and performance, pumps should be specified so that daily operation parameters will fall in the center of the pump performance curve.

**A200P
PTFE-FITTED**

Height 434 mm (17.1")
 Width 457 mm (18.0")
 Depth 257 mm (10.1")
 Est. Ship Weight.....
 Polypropylene 14 kg (31 lbs)
 PVDF 19 kg (41 lbs)
 Air Inlet 6 mm (1/4")
 Inlet 25 mm (1")
 Outlet 25 mm (1")
 Suction Lift 4.8 m Dry (15.9')
 9.3 m Wet (30.6')
 Displacement/Stroke 0.34 l (0.09 gal.)¹
 Max. Flow Rate 170 lpm (45 gpm)
 Max. Size Solids..... 4.8 mm (3/16")

¹Displacement per stroke was calculated at 4.8 bar (70 psig) air inlet pressure against a 2 bar (30 psig) head pressure.

Example: To pump 30.3 lpm (8 gpm) against a discharge pressure head of 4.1 bar (60 psig) requires 5.5 bar (80 psig) and 20.4 Nm³/h (12 scfm) air consumption.

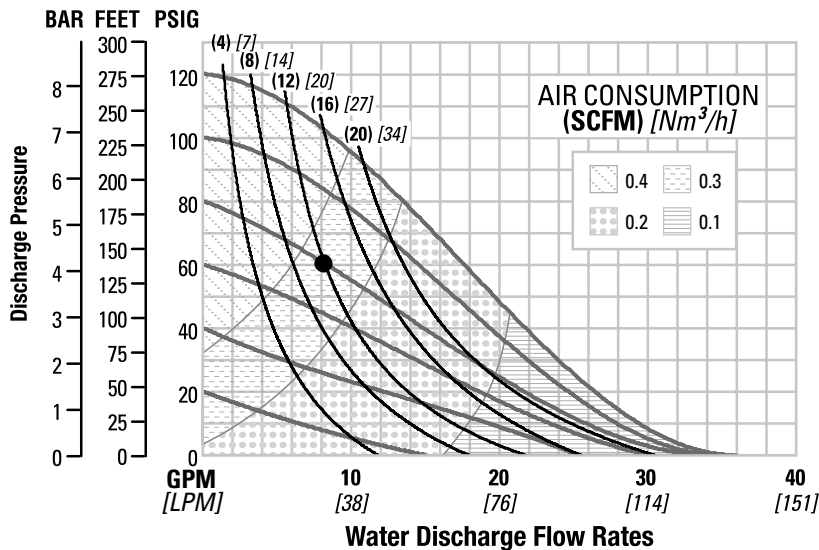

Flow rates indicated on chart were determined by pumping water.

For optimum life and performance, pumps should be specified so that daily operation parameters will fall in the center of the pump performance curve.

SUCTION LIFT CURVES

**A200P ADVANCED™
PLASTIC SUCTION
LIFT CAPABILITY**

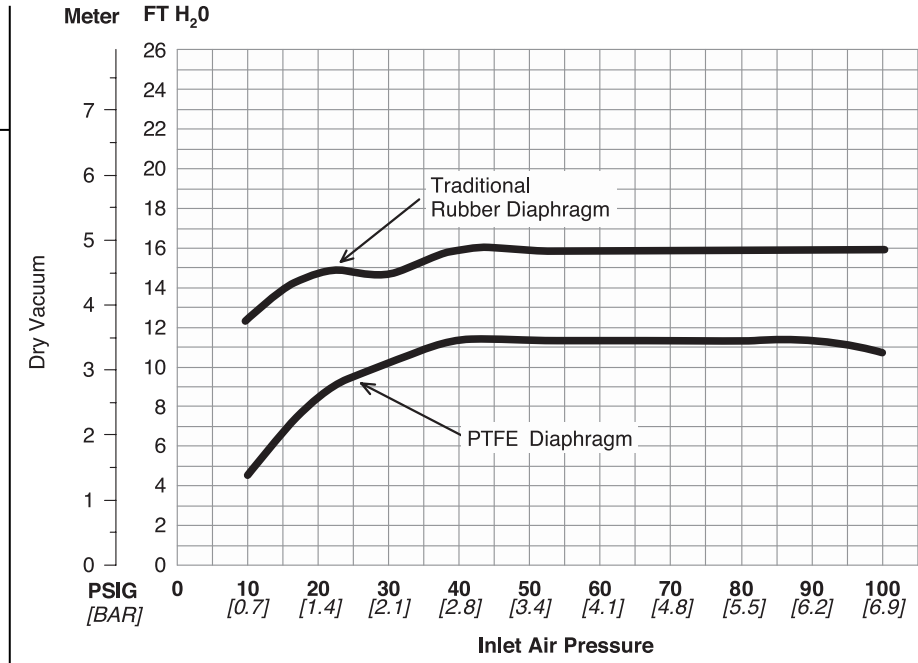

These curves demonstrate the flow created when the stroke rate is modified under static air and fluid pressure condition.

This curve can be applied to different pressure conditions to estimate the change in flow due to stroke rate.

SUGGESTED INSTALLATION

All Wilden pumps are manufactured with a variety of materials for the air distribution system, liquid path and elastomers. This variety is offered to satisfy the temperature, chemical compatibility, abrasion and flex life requirements for most applications. Consult manual for available materials and temperature limitations for this pump model.

For Accu-Flo™ models only, all wiring used to operate the pump should be placed and connected according to all applicable electrical codes. It is important that the wiring be of adequate gauge to carry the current required to operate the pump. In addition, it is necessary that the electrical power supply be large enough to supply the current required to operate the pump. Wiring should be above ground level if possible (in case of fluid spill or leakage), and all wiring and connections which could become wet or damp should be made watertight.

The suction pipe used for installation should be sized equal to, or greater than, the pump liquid inlet connection. This will minimize pump cavitation and potential blockages of the pump inlet. The discharge piping should also be sized equal to, or greater than, the pump liquid discharge connection. If the pump is to be used in a self-priming application, be sure that all connections are airtight and that the suction lift is within the pump's ability. (Consult manual for suction lift information.) Note: Materials of construction and elastomer materials have an effect on suction lift parameters.

INSTALLATION: Months of careful planning, study, and selection efforts can result in unsatisfactory pump performance if installation details are left to chance.

Premature failure and long term dissatisfaction can be avoided if reasonable care is exercised throughout the installation process.

LOCATION: Noise, safety, and other logistical factors usually dictate where equipment should be situated on the production floor. Multiple installations with conflicting requirements can result in congestion of utility areas, leaving few choices for additional pumps.

Within the framework of these and other existing conditions, every pump should be located in such a way that five key factors are balanced against each other to maximum advantage.

ACCESS: First, the location should be accessible. If it is easy to reach the pump, maintenance personnel will have an easier time carrying out routine inspections and adjustments. Should major repairs become necessary, ease of access can play a key role in speeding the repair process and reducing total downtime.

AIR SUPPLY: Every pump location should have an air line large enough to supply the volume of air necessary to achieve the desired pumping rate (see Section 5).

For best results, the pumps should use a 5 μ (micron) air filter, needle valve and regulator. The use of an air filter before the pump will insure that the majority of any pipeline contaminants will be eliminated.

SOLENOID OPERATION: When operation is controlled by a solenoid valve in the air line, three-way valves should be

used, thus allowing trapped air to bleed off and improving pump performance. Pumping volume can be set by counting the number of strokes per minute and multiplying by displacement per stroke.

SOUND: Sound levels are reduced using the standard Wilden muffler element. Other mufflers can be used, but usually reduce pump performance.

ELEVATION: Selecting a site that is well within the pump's dynamic lift capability will assure that loss-of-prime troubles will be eliminated. In addition, pump efficiency can be adversely affected if proper attention is not given to site location.

PIPING: Final determination of the pump site should not be made until the piping problems of each possible location have been evaluated. The impact of current and future installations should be considered ahead of time to make sure that inadvertent restrictions are not created for any remaining sites.

The best choice possible will be a site involving the shortest and straightest hook-up of suction and discharge piping. Unnecessary elbows, bends, and fittings should be avoided. Pipe sizes should be selected to keep friction losses within practical limits. All piping should be supported independently of the pump. In addition, the piping should be aligned to avoid placing stresses on the pump fittings.

Flexible hose can be installed to aid in absorbing the forces created by the natural reciprocating action of the pump. If the pump is to be bolted down to a solid location, a mounting pad placed between the pump and the foundation will assist in minimizing pump vibration. Flexible connections between the pump and rigid piping will also assist in minimizing pump vibration. If quick-closing valves are installed at any point in the discharge system, or if pulsation within a system becomes a problem, a surge suppressor should be installed to protect the pump, piping and gauges from surges and water hammer.

When pumps are installed in applications involving flooded suction or suction head pressures, a gate valve should be installed in the suction line to permit closing of the line for pump service.

If the pump is to be used in a self-priming application, be sure that all connections are airtight and that the suction-lift is within the ability of the model. Note: Materials of construction and elastomer material have an effect on suction lift parameters. Please consult Wilden distributors for specifics.

Pumps in service with a positive suction head are most efficient when inlet pressure is limited to 0.5–0.7 bar (7–10 psig). Premature diaphragm failure may occur if positive suction is 0.7 bar (10 psig) and higher.

WHENEVER THE POSSIBILITY EXISTS THAT LARGE SOLID OBJECTS MAY BE SUCKED INTO THE PUMP, A STRAINER SHOULD BE USED ON THE SUCTION LINE.

CAUTION: DO NOT EXCEED RATED MAXIMUM PRESSURE AS STATED IN CAUTIONS AND WARNINGS, SECTION 1.

SUGGESTED INSTALLATION

This illustration is a generic representation of an air-operated double-diaphragm pump.

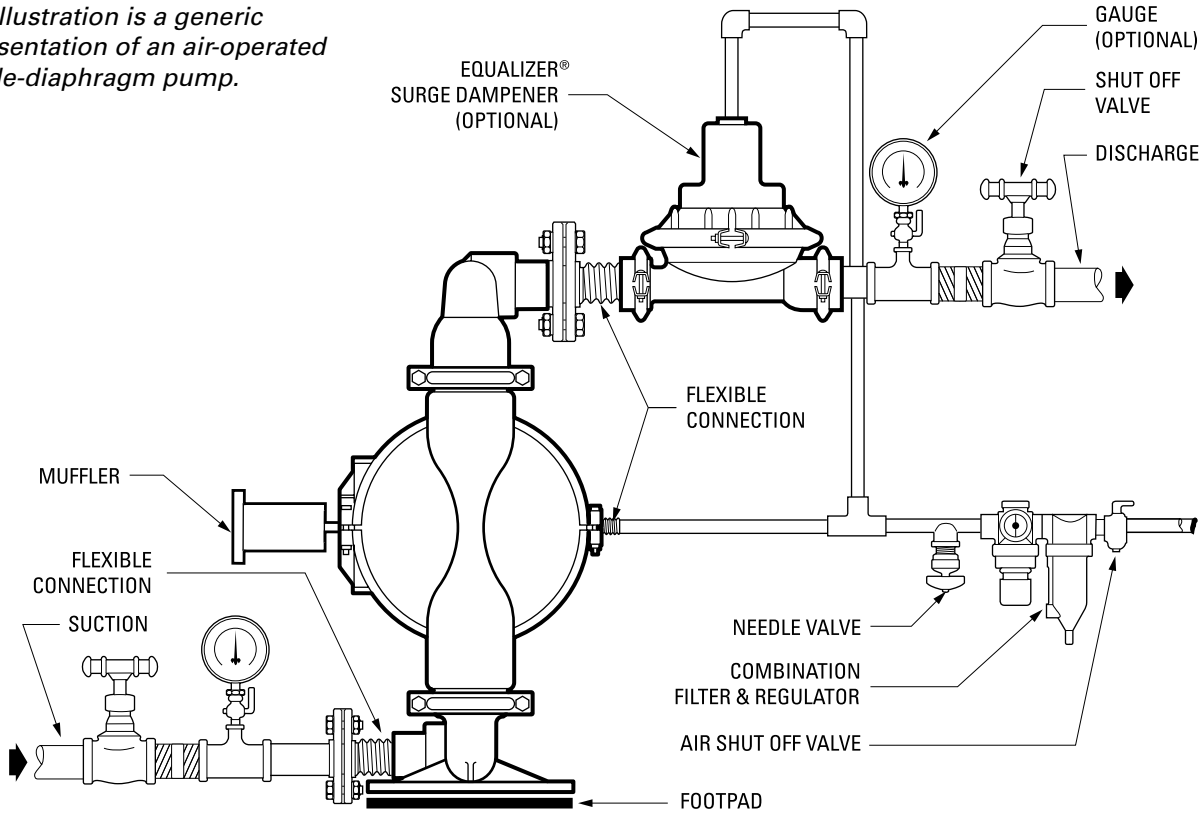

NOTE: In the event of a power failure, the shut off valve should be closed, if the restarting of the pump is not desirable once power is regained.

AIR OPERATED PUMPS: To stop the pump from operating in an emergency situation, simply close the

shut off valve (user supplied) installed in the air supply line. A properly functioning valve will stop the air supply to the pump, therefore stopping output. This shut off valve should be located far enough away from the pumping equipment such that it can be reached safely in an emergency situation.

OPERATING PRINCIPLES

OPERATION: The A200P is pre-lubricated, and does not require in-line lubrication. Additional lubrication will not damage the pump, however if the pump is heavily lubricated by an external source, the pump's internal lubrication may be washed away. If the pump is then moved to a non-lubricated location, it may need to be disassembled and re-lubricated as described in the ASSEMBLY/DISASSEMBLY INSTRUCTIONS.

Pump discharge rate can be controlled by limiting the solenoid, the volume, and/or pressure of the air supply to the pump. A regulator is used to control air pressure while a needle valve is used to control volume. Pump discharge rate can also be controlled by throttling the pump discharge by partially closing a valve in the discharge line of the pump. This action increases friction loss which reduces flow rate. (See Section 5.) This is useful when the need exists to control the pump from a remote location. When the pump discharge pressure equals or exceeds the air supply pressure, the pump will stop; no bypass or pressure relief valve is needed, and pump damage will not occur. The pump has reached a "deadhead" situation and can be restarted by reducing the fluid discharge pressure or increasing the air inlet pressure. The Wilden A200P pump runs solely on compressed air and does not generate heat, therefore your process fluid temperature will not be affected.

MAINTENANCE AND INSPECTIONS: Since each application is unique, maintenance schedules may be different for every pump. Frequency of use, line pressure, viscosity and abrasiveness of process fluid all affect the parts life of a Wilden pump. Periodic inspections have been found to offer the best means for preventing unscheduled pump downtime. Personnel familiar with the pump's construction and service should be informed of any abnormalities that are detected during operation.

RECORDS: When service is required, a record should be made of all necessary repairs and replacements. Over a period of time, such records can become a valuable tool for predicting and preventing future maintenance problems and unscheduled downtime. In addition, accurate records make it possible to identify pumps that are poorly suited to their applications.

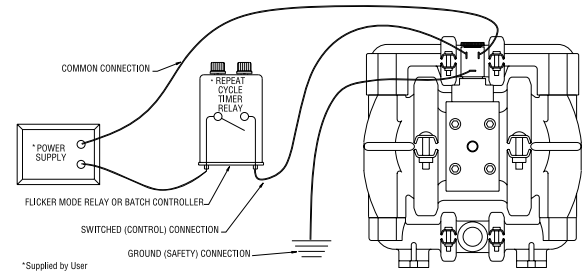

SUGGESTED OPERATION & MAINTENANCE

The pump will not shift reliably unless the minimum supply pressure is provided. For the A200P the minimum supply pressure for reliable operation is 2.7 bar (40 psig).

The solenoid operated pump is permanently lubricated during assembly, and requires no additional lubrication under normal operation. If the unit runs under extreme conditions (continuous operation at high speeds), it may be necessary to relubricate the center block with a buna-n compatible white bearing grease every 50 million cycles. Continuous lubrication with a compatible oil is not harmful, and will provide longer seal life, but it may flush all grease out of the unit.

A red button on the side of the air valve is a manual override; when actuated it will shift the valve as if an electric current had actuated the solenoid.

RECORDS: When service is required, a record should be made of all necessary repairs and replacements. Over a period of time, such records can become a valuable

tool for predicting and preventing future maintenance problems and unscheduled downtime. In addition, accurate records make it possible to identify pumps that are poorly suited to their applications.

MAINTENANCE AND INSPECTIONS: Since each application is unique, maintenance schedules may be different for every pump. Frequency of use, line pressure, viscosity and abrasiveness of process fluid all effect the parts life of a Wilden pump. Periodic inspections have been found to offer the best means for preventing unscheduled pump downtime. Personnel familiar with the pump's construction and service should be informed of any abnormalities that are detected during operation. Internal maintenance is not recommended for Accu-Flo™ solenoid air valves. When worn or damaged, a new air valve body, coil or terminal connector must be purchased. Please consult Section 8 for part numbers.

Pump will not run.

1. Check for pressurized air at the inlet.
2. Check air inlet and filter for debris.
3. Connect a test lamp to the two wires which run to pump and ensure that the lamp cycles on and off.
4. Make sure that the air valve manual override (small red knob on front of valve) is switched to the "0" position.
5. Check pilot pressure vent at the top of the operator/coil assembly to ensure that it is not clogged.
6. Check for a worn out air valve. If air continually blows out the exhaust in very large quantities, the air valve seals may be worn beyond their ability to function. In this case, the valve must be replaced.

NOTE: Before the valve is scrapped, it is possible that it may be saved by completely disassembling the valve, cleaning all components and relubricating the valve.

Pump runs but little or no fluid comes out.

1. Check that the discharge isolation valve is not closed.
2. Check that the electronic signal is slow enough that the pump is able to complete each physical stroke before it is signaled to change direction. The time required to complete the stroke is determined by a variety of factors which include fluid viscosity and head pressure.
3. Check for pump cavitation; slow pump speed down to match the thickness of the material being pumped.
4. Check for sticking ball check valves. If the material being pumped is not compatible with the pump elastomers, swelling may occur. Replace ball check valves and o-ring with the proper elastomers.
5. Check to make sure that all suction connections are air tight, and that the clamp bands are properly tightened.

Pump air passages blocked with ice.

1. Check for excessive moisture in compressed air line. As the air expands out the exhaust during the operation of the pump, water vapor entrapped in the compressed air can freeze and block the air passageways in the pump. If this occurs, it may be necessary to install a coalescing filter, an air dryer, or a hot air generator for the compressed air.

Air bubbles in pump discharge.

1. Check for ruptured diaphragm.
2. Check tightness of clamp bands, and the integrity of the o-rings, especially at intake manifold.

Product comes out air exhaust.

1. Check for diaphragm rupture.
2. Check tightness of piston plates to shaft.

Pump rattles.

1. See E10 Troubleshooting Guide.
2. Create false discharge head or suction lift.

Solenoid buzzes or solenoid burnout.

1. Incorrect voltage, faulty or dirty solenoid.

Solenoid valve fails to shift electrically but shifts with manual override.

1. Incorrect voltage, defective coil or wiring.

Solenoid valve fails to shift electrically or with manual override.

1. Inadequate air supply, contamination, inadequate or improper lubrication, mechanical binding in the valve.

Valve shifts but fails to return.

1. Broken spring, mechanical binding.

Excessive leaking from air valve vent.

1. Worn seals in air valve.

Control the Flow

P U M P A C C E S S O R I E S

SPCI

SOLENOID PUMP CONTROLLER



- Designed to complement and expand the application range for Accu-Flo™ pumps
- Automate your process
- Control flow rate remotely
- Interface with external inputs
- Preventative maintenance indicator

Power Requirement:

110-120V AC @ 50/60 Hz., 220-240V AC @ 50 Hz.

Pump Output Voltage & Amps:

12V DC at no greater than 0.4 amps.

External Input Activation:

Dry contact less than 1 mA

WILDEN
A DOVER COMPANY

22069 VAN BUREN STREET • GRAND TERRACE, CA 92313-5607
(909) 422-1730 • FAX (909) 783-3440
www.wildenpump.com

EXPLODED VIEW AND PARTS LISTING

A200P ADVANCED™ PLASTIC

Rubber/TPE-Fitted

EXPLODED VIEW

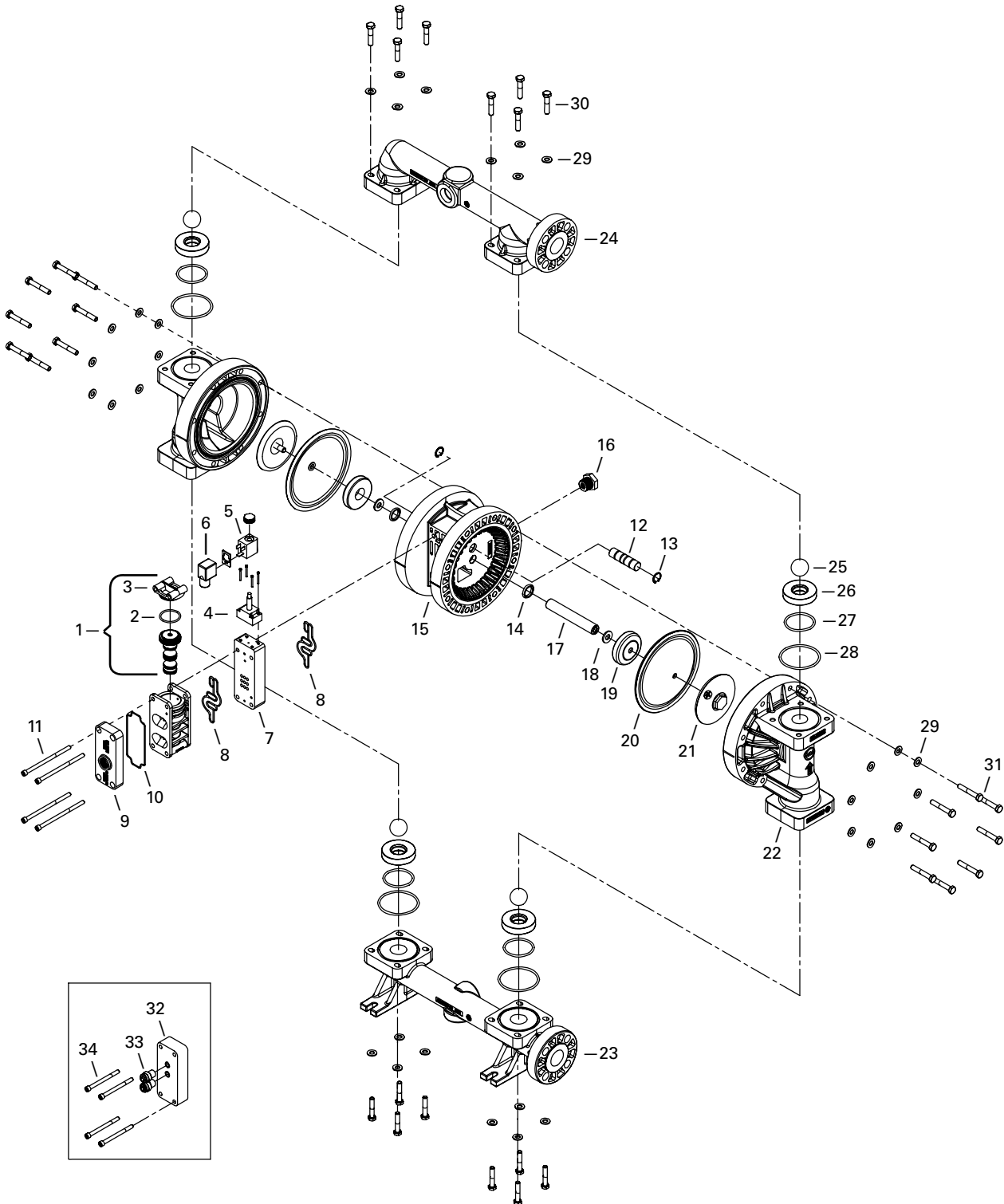

EXPLODED VIEW AND PARTS LISTING

A200P ADVANCED™ PLASTIC

Rubber/TPE-Fitted

PARTS LISTING

No.	Part Description	Qty.	A200P/PKPPP	A200P/KKPPP	A200P/TTPPP
1	Assembly, Air Valve, P1/P2	1	01-2010-20	01-2010-20	01-2010-20
2	O-Ring, End Cap	1	01-2395-52	01-2395-52	01-2395-52
3	End Cap	1	01-2332-20	01-2332-20	01-2332-20
4	Operator, Solenoid, NEMA 4	1	00-2120-99	00-2120-99	00-2120-99
5	Coil	1	***	***	***
6	Connector, Solenoid Coil	1	00-2130-99	00-2130-99	00-2130-99
7	Solenoid Spacer Plate, P1/P2, Poly	1	01-2160-20	01-2160-20	01-2160-20
8	Gasket, Air Valve, Pro-Flo®	2	01-2615-52	01-2615-52	01-2615-52
9	Muffler Plate, Pro-Flo®	1	01-3181-20	01-3181-20	01-3181-20
10	Gasket, Muffler Plate	1	01-3505-52	01-3505-52	01-3505-52
11	Screw, SHC, 1/4-20 X 4.00	4	02-6002-03	02-6002-03	02-6002-03
12	Assembly, Pilot Plug, A2P	1	P02-2285-99	P02-2285-99	P02-2285-99
13	Retaining Ring	2	00-2650-03	00-2650-03	00-2650-03
14	Glyd™ Ring II	2	02-3210-55-225	02-3210-55-225	02-3210-55-225
15	Center Section, P200, Poly	1	02-3141-20	02-3141-20	02-3141-20
16	Bushing Reducer	1	01-6950-20	01-6950-20	01-6950-20
17	Shaft, Straight, P2	1	02-3810-03	02-3810-03	02-3810-03
18	Washer, Disc Spring (.413 X.906)	2	02-6802-08	02-6802-08	02-6802-08
19	Piston, Inner, P2	2	02-3701-01	02-3701-01	02-3701-01
20	Diaphragm, Primary	2	*	*	*
21	Piston, Outer, P2	2	02-4570-21-500	02-4570-21-500	02-4570-22-500
22	Chamber, Liquid, Adv	2	02-5005-20	02-5005-21	02-5005-22
23	Manifold, Inlet, ANSI ²	1	02-5090-20	02-5090-21	02-5090-22
24	Manifold, Discharge, ANSI ¹	1	02-5030-20	02-5030-21	02-5030-22
25	Ball, Valve	4	*	*	*
26	Seat, Valve, Bolted, Poly	4	02-1125-20	02-1125-21	01-1160-55
27	O-Ring (1.859 X.139)	4	*	*	*
28	O-Ring (2.734 X.139)	4	*	*	*
29	Washer, Flat, 5/16	32	02-6731-03	02-6731-03	02-6731-03
30	Screw, HHC, 5/16-18 X 1.50	16	02-6181-03	02-6181-03	02-6181-03
31	Screw, HHC, 5/16-18 X 2	16	02-6191-03	02-6191-03	02-6191-03
	Muffler, 1/2" (not pictured)	1	02-3510-99	02-3510-99	02-3510-99

* Refer to corresponding elastomer chart in Section 8

*** Refer to coil voltage selection chart in Section 8

¹DIN Flange: Polypropylene = 02-5031-02, PVDF = 02-5031-21

²DIN Flange: Polypropylene = 02-5091-02, PVDF = 02-5091-21

All boldface items are primary wear parts.

ADAPTER BLOCK OPTION FOR A200B

No.	Part Description	Qty.	A200P/PPPP
32	Adapter Block	1	00-2155-20
33	Fitting, Air Inlet	2	00-2170-20
34	Screw, HHC	4	04-6000-03

EXPLODED VIEW AND PARTS LISTING

A200P ADVANCED™ PLASTIC

PTFE-Fitted

EXPLODED VIEW

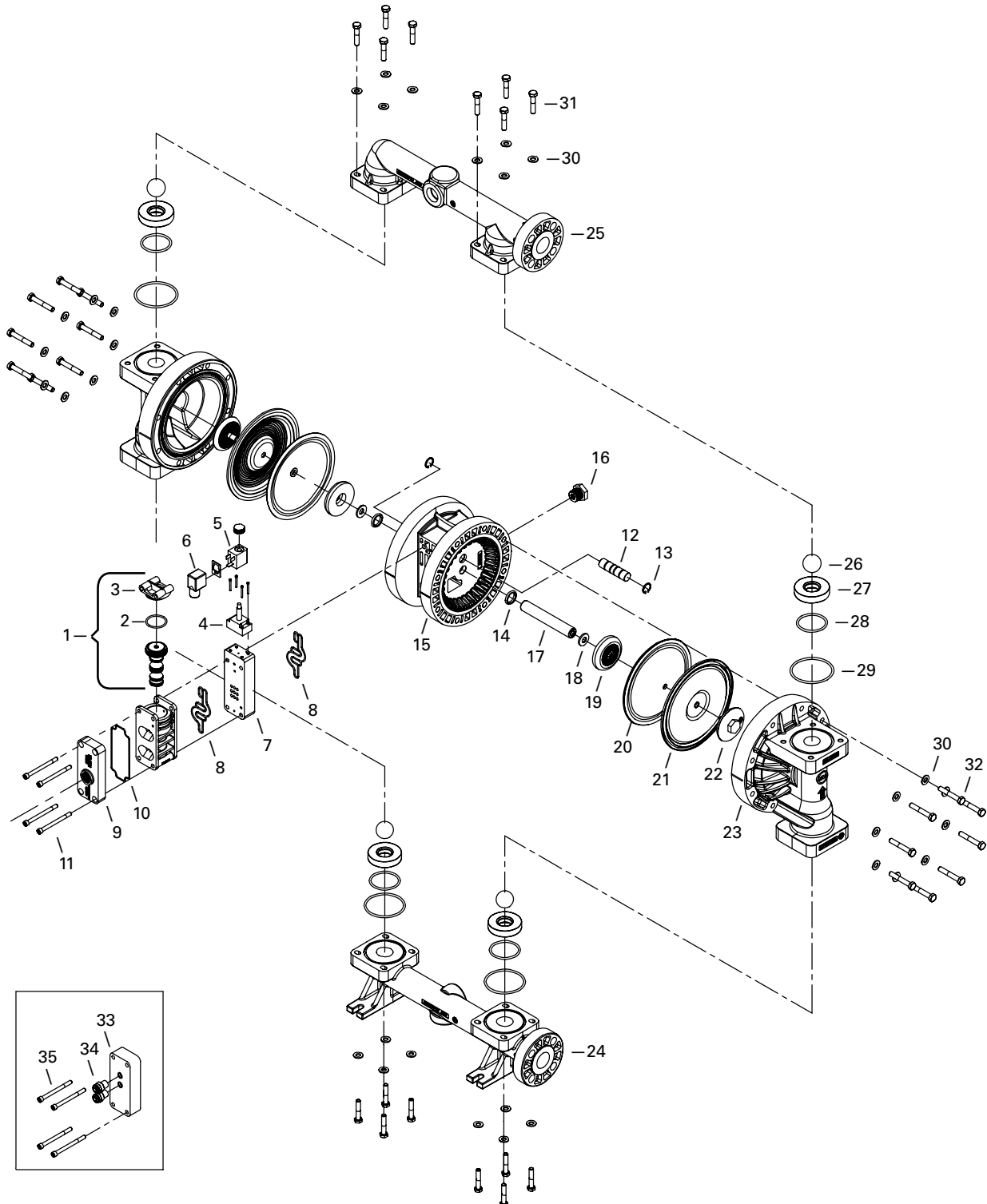

EXPLODED VIEW AND PARTS LISTING

A200P ADVANCED™ PLASTIC

PTFE-Fitted

PARTS LISTING

No.	Part Description	Qty.	A200P/PKPPP	A200P/KKPPP	A200P/TTPPP
1	Assembly, Air Valve, P1/P2	1	01-2010-20	01-2010-20	01-2010-20
2	O-Ring, End Cap	1	01-2395-52	01-2395-52	01-2395-52
3	End Cap	1	01-2332-20	01-2332-20	01-2332-20
4	Operator, Solenoid, NEMA 4	1	00-2120-99	00-2120-99	00-2120-99
5	Coil	1	***	***	***
6	Connector, Solenoid Coil	1	00-2130-99	00-2130-99	00-2130-99
7	Solenoid Spacer Plate, P1/P2, Poly	1	01-2160-20	01-2160-20	01-2160-20
8	Gasket, Air Valve, Pro-Flo®	2	01-2615-52	01-2615-52	01-2615-52
9	Muffler Plate, Pro-Flo®	1	01-3181-20	01-3181-20	01-3181-20
10	Gasket, Muffler Plate	1	01-3505-52	01-3505-52	01-3505-52
11	Screw, SHC, 1/4-20 X 4.00	4	02-6002-03	02-6002-03	02-6002-03
12	Assembly, Pilot Plug, A2P	1	P02-2285-99	P02-2285-99	P02-2285-99
13	Retaining Ring	2	00-2650-03	00-2650-03	00-2650-03
14	Glyd™ Ring II	2	02-3210-55-225	02-3210-55-225	02-3210-55-225
15	Center Section, P200, Poly	1	02-3141-20	02-3141-20	02-3141-20
16	Bushing Reducer	1	01-6950-20	01-6950-20	01-6950-20
17	Shaft, Straight, P2	1	02-3840-03	02-3840-03	02-3840-03
18	Washer, Disc Spring (.413 X.906)	2	02-6802-08	02-6802-08	02-6802-08
19	Piston, Inner, P2	2	02-3751-01	02-3751-01	02-3751-01
20	Diaphragm, Back-Up, Neoprene	2	02-1060-51	02-1060-51	02-1060-51
21	Diaphragm, Primary	2	02-1010-55	02-1010-55	02-1010-55
22	Piston, Outer, P2	2	02-4570-21-500	02-4570-21-500	02-4570-22-500
23	Chamber, Liquid, Adv	2	02-5005-20	02-5005-21	02-5005-22
24	Manifold, Inlet, ANSI ¹	1	02-5090-20	02-5090-21	02-5090-22
25	Manifold, Discharge, ANSI ¹	1	02-5030-20	02-5030-21	02-5030-22
26	Ball, Valve, PTFE	4	02-1085-55	02-1085-55	02-1085-55
27	Seat, Valve, Bolted, Poly	4	02-1125-20	02-1125-21	02-1160-22
28	O-Ring (1.859 X.139)	4	02-1220-60	02-1220-60	02-1220-60
29	O-Ring (2.734 X.139)	4	04-1300-60-500	04-1300-60-500	04-1300-60-500
30	Washer, Flat, 5/16	32	02-6731-03	02-6731-03	02-6731-03
31	Screw, HHC, 5/16-18 X 1.50	16	02-6181-03	02-6181-03	02-6181-03
32	Screw, HHC, 5/16-18 X 2	16	02-6191-03	02-6191-03	02-6191-03
	Muffler, 1/2" (not pictured)	1	02-3510-99	02-3510-99	02-3510-99

* Refer to corresponding elastomer chart in Section 8

*** Refer to coil voltage selection chart in Section 8

¹DIN Flange: Polypropylene = 02-5031-02, PVDF = 02-5031-21

²DIN Flange: Polypropylene = 02-5091-02, PVDF = 02-5091-21

All boldface items are primary wear parts.

ADAPTER BLOCK OPTION FOR A200B

No.	Part Description	Qty.	A200P/PPPP
33	Adapter Block	1	00-2155-20
34	Fitting, Air Inlet	2	00-2170-20
35	Screw, HHC	4	04-6000-03

ELASTOMER OPTIONS

A200 PLASTIC ADVANCED™ PUMPS

MATERIAL	COLOR CODE	DIAPHRAGM (2) P/N	VALVE BALL (4) P/N	VALVE SEAT O-RING (4) P/N	FLANGE O-RING (4) P/N	BACKUP DIAPHRAGM P/N
Polyurethane	Natural	02-1010-50	02-1085-50	02-1220-50	04-1300-50-500	N/A
Buna-N	Red	02-1010-52	02-1085-52	04-2390-52-700	04-1300-52-500	N/A
PTFE Encapsulated Viton®	None	N/A	N/A	02-1220-60	04-1300-60-500	N/A
Neoprene	Green	02-1010-51	02-1085-51	N/A	N/A	02-1060-56
Viton®	Silver	02-1010-53	02-1085-53	N/A	N/A	N/A
EPDM	Blue	02-1010-54	02-1085-54	N/A	N/A	02-1060-54 ¹
PTFE®	White	02-1010-55	02-1085-55	N/A	N/A	N/A
Tetra-Flex™ PTFE w/Neoprene	White	02-1010-64	N/A	N/A	N/A	N/A
Tetra-Flex™ PTFE w/EPDM	White	02-1010-81	N/A	N/A	N/A	N/A
Saniflex™	Off-White	02-1010-56	02-1085-56	N/A	N/A	02-1060-56 ¹
Wil-Flex™	Orange	02-1010-58	02-1085-58	02-1220-58	02-1370-58	N/A

¹Saniflex™ and EPDM back-up diaphragms are available upon request. Please consult your local distributor.

SOLENOID-OPERATED VALVE ASSEMBLY OPTIONS (CONSISTS OF VALVE BODY, COIL AND CONNECTOR)

PUMP MODELS DESIGNATING SPECIALTY CODE #	PART NUMBER	DESCRIPTION
150	02-2000-99-150	24V DC Valve Assembly
151	02-2000-99-151	24V AC / 12V DC Valve Assembly
153	02-2000-99-153	24V AC / 12V DC Valve Assembly (Nema 7)
154	02-2000-99-154	24V DC Valve Assembly (Nema 7)
155	02-2000-99-155	110V AC Valve Assembly
156	02-2000-99-156	110V AC Valve Assembly (Nema 7)
157	02-2000-99-157	International 24V DC Valve Assembly ¹

Item 1 Main Valve Body Options

PART NUMBER	DESCRIPTION
02-2000-01-150	Main Valve Body
02-2000-01-154	Main Valve Body (Nema 7)

Item 2 Coil Options

PUMP MODELS DESIGNATING SPECIALTY CODE #	PART NUMBER	DESCRIPTION
150	00-2110-99-150	24V DC Coil
151	00-2110-99-151	24V AC Coil
153	00-2110-99-153	24V AC, Nema 7 Coil
154	00-2110-99-154	24V DC, Nema 7 Coil
155	00-2110-99-155	110V AC Coil
156	00-2110-99-156	110V AC Nema 7 Coil
157	00-2110-99-157	International 24V DC Coil ¹

¹Meets European standards and regulations; CENELEC/PTB File #EX-91.C.2027.

WARRANTY

Each and every product manufactured by Wilden Pump and Engineering, LLC is built to meet the highest standards of quality. Every pump is functionally tested to insure integrity of operation.

Wilden Pump and Engineering, LLC warrants that pumps, accessories and parts manufactured or supplied by it to be free from defects in material and workmanship for a period of five (5) years from date of installation or six (6) years from date of manufacture, whichever comes first. Failure due to normal wear, misapplication, or abuse is, of course, excluded from this warranty.

Since the use of Wilden pumps and parts is beyond our control, we cannot guarantee the suitability of any pump or part for a particular application and Wilden Pump and Engineering, LLC shall not be liable for any consequential damage or expense arising from the use or misuse of its products on any application. Responsibility is limited solely to replacement or repair of defective Wilden pumps and parts.

All decisions as to the cause of failure are the sole determination of Wilden Pump and Engineering, LLC.

Prior approval must be obtained from Wilden for return of any items for warranty consideration and must be accompanied by the appropriate MSDS for the product(s) involved. A Return Goods Tag, obtained from an authorized Wilden distributor, must be included with the items which must be shipped freight prepaid.

The foregoing warranty is exclusive and in lieu of all other warranties expressed or implied (whether written or oral) including all implied warranties of merchantability and fitness for any particular purpose. No distributor or other person is authorized to assume any liability or obligation for Wilden Pump and Engineering, LLC other than expressly provided herein.

PLEASE PRINT OR TYPE AND FAX TO WILDEN

PUMP INFORMATION

Item # _____

Serial # _____

Company Where Purchased _____

YOUR INFORMATION

Company Name _____

Industry _____

Name _____

Title _____

Street Address _____

City _____

State _____

Postal Code _____

Country _____

Telephone _____

Fax _____

E-mail _____

Web Address _____

Number of pumps in facility? _____

Number of Wilden pumps? _____

Types of pumps in facility (check all that apply): Diaphragm Centrifugal Gear Submersible Lobe Other _____

Media being pumped? _____

How did you hear of Wilden Pump? Trade Journal Trade Show Internet/E-mail Distributor Other _____**ONCE COMPLETE, FAX TO (909) 783-3440**

NOTE: WARRANTY VOID IF PAGE IS NOT FAXED TO WILDEN

WILDEN PUMP & ENGINEERING, LLC



ADVANCED S E R I E S

Advance Your Process

Advanced wetted path designs
Lower the cost of operation
Maximize product containment
Longer MTBF (Mean Time Between Failures)
Enhanced internal clearance
The result of advanced thought



UNITEC™ S E R I E S

Enrich Your Process

Simplicity of design
Unique Technology
Reliable, leak-free & quiet
Validated & certified
Intrinsically safe
The result of unique thought



SANIFLO™ S A N I T A R Y P U M P T E C H N O L O G Y

Refine Your Process

Designed for sanitary applications
Minimize product degradation
Improved production yields
Easy to inspect, clean & assemble
Minimized water requirements
The result of progressive thought



ULTRAPURE P T F E P R O C E S S P U M P S

Optimize Your Process

Validated & certified
Clean room assembled
Low particle count
Compact, efficient & quiet
Runs on clean-dry air
The result of pure thought



ORIGINAL S E R I E S

Simplify Your Process

Long standing design simplicity
Portable & submersible
Variable connection options
Fewest parts in industry
Solutions since 1955
The result of original thought

ACCESSORIES

Maximize Your Process

Electronic control & monitoring
Level control & containment
Pulsation dampening
Drum unloading systems
Complete system solutions
The result of innovative thought

WILDEN®

A DOVER COMPANY

22069 VAN BUREN STREET • GRAND TERRACE, CA 92313-5607
(909) 422-1730 • FAX (909) 783-3440
www.wildenpump.com

Your Local Authorized Distributor:

airpumping.co.uk

est. 1979

Unit 16, Uppminster Trading Park, Warley St., Uppminster, Essex, RM14 3PJ, ENGLAND