

**Check Valves for SAE Flange Ports,
Fit between Port and Flange, O-rings on both Faces
Series RVSAE 3/6DS..., 1200 l/min, 420 bar
Patent No. 38 34 066**

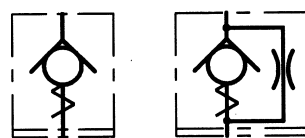

180°-inverted installation

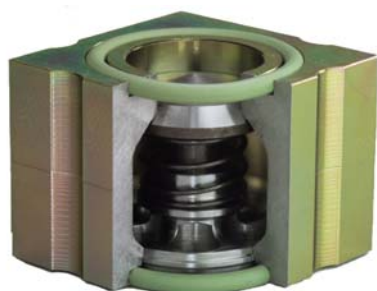
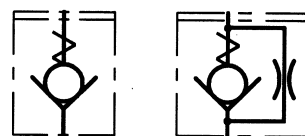

When 2 mating faces both have O-rings,
an insert plate, type ZPSAE...,
must be used.

1 General

1.1 Product description

These patented dual-purpose SAE check valves are centred between the shafts of the four SAE flange bolts. This results in a compact, easy-to-install assembly.

The valves can be used without modification on both 3000 psi (210 bar) and 6000 psi (420 bar) SAE flange ports (does not apply to the 2½" size).

The no-flow direction can be reversed by inverting the valve.

Insert plates for sealing are available as required – see also valve series RVSAE3/6.... with O-ring on one face (Data Sheet 170-P-060000-E).

The valve design is based on a guided poppet that is hardened and ground.

In the no-flow direction, the valve closes.

The valves can be used for pressure relief in the opening direction, but only to a limited extent (consult Bucher Hydraulics for such applications).

1.2 Advantages

- Virtually leak-free
- High dynamic pressure rating
- Compact construction
- The same valve body is used for 3000 psi and 6000 psi ports
- Same valve body is used for no-flow directions A → B and B → A
- Optional orifice for metered flow in the no-flow direction

2 Main characteristics

Designation	SAE check valve
Design	guided spherical-poppet design
Mounting method	fits between port and flange
Size	for SAE ¾" to 2½" flange ports
Dimensions	see Table in section 5, Dimensions
Mounting attitude	unrestricted
No-flow direction	reversible by inverting the valve (see symbol)
Operating pressure range	...6000 psi (420 bar)
Opening pressure	0.2 ... 4 bar
Flow rate, Q max.	...1200 l/min
Fluid	HL and HLP hydraulic oils to DIN 51524. Other fluids, contact Bucher Hydraulics
Temperature range	-30°C... +80°C
Viscosity range	10 ... 500 mm²/s (cSt)
Min. fluid cleanliness	18/14 to ISO 4406 / CETOP RP70H, 8...9 to NAS 1638

For applications outside these parameters, please contact Bucher Hydraulics.

3 Schematic section

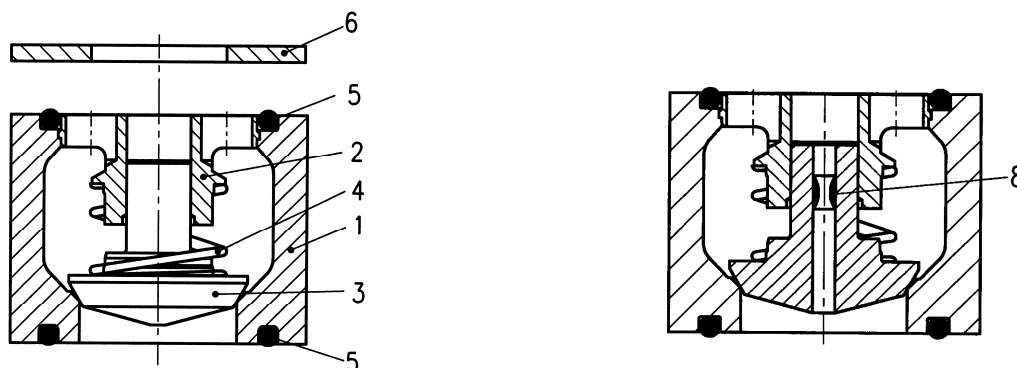

4 Components

Item	Qty.	Description
1	1	Body
2	1	Guide bush
3	1	Spherical poppet
4	1	Spring
5	2	O-ring
6	-	Insert plate (if required, order separately)
8	-	Metering orifice (optional model: RVSAE...-D1x...-...)

5 Dimensions

5.1 Dimensions - valves

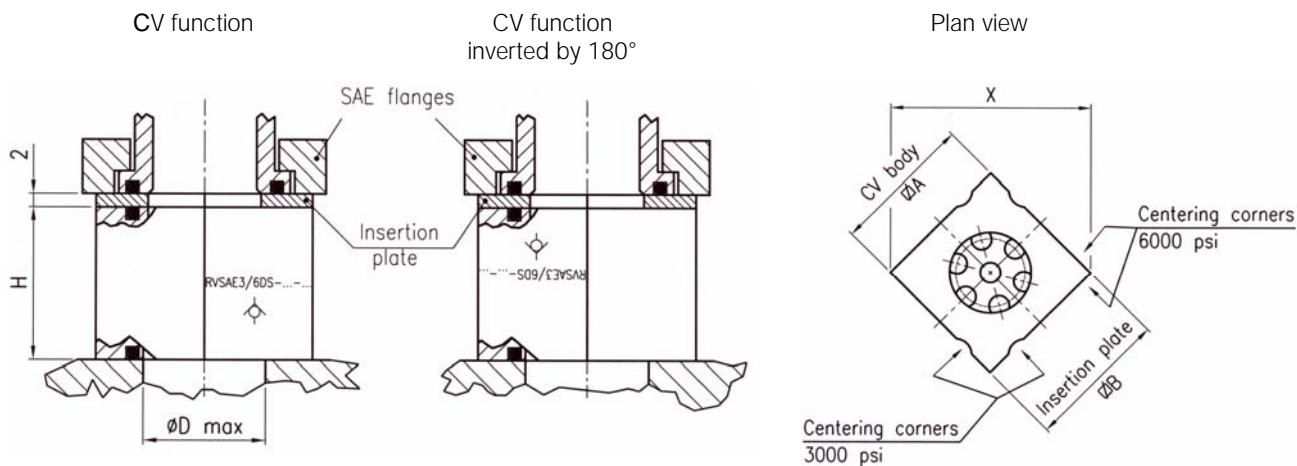

3000 / 6000 psi (210 / 420 bar)		H	A	B	ØD	X	O-rings
	RVSAE3/6DS-34-...	33	42.5	42.5	19	60	24.99 x 3.53 N90
	RVSAE3/6DS-11-...	38	47.9	47.9	25	68	32.92 x 3.53 N90
	RVSAE3/6DS-114-...	43	55.4	55.4	29.5	78.5	37.69 x 3.53 N90
	RVSAE3/6DS-112-...	48	65.8	65.8	35	93	47.22 x 3.53 N90
	RVSAE3/6DS-21-...	63	79.7	79.7	42	113	53.57 x 3.53 N90
	RVSAE3DS-212-...	85	94	94	53.8	132.95	69.45 x 3.53 N90
	RVSAE6DS-212-...	85	104	104	53.8	147.1	69.45 x 3.53 N90

5.2 Dimensions – SAE flange ports

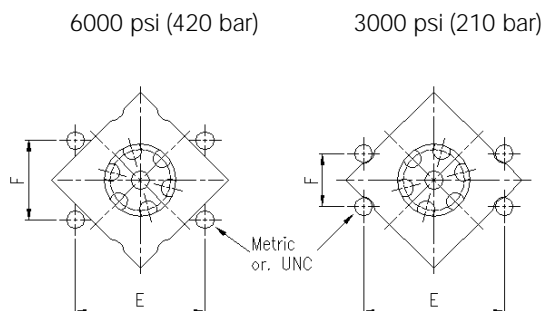

Check valve model		Suitable for flange:				Tightening torque for the flange bolts
		E	F	M	UNC	
3000 psi (210 bar)	RVSAE3/6DS-34-...	47,6	22,2	M 10	3/8"	The tightening torque depends on the grade of the connecting bolts that are used at the SAE flange port
	RVSAE3/6DS-11-...	52,4	26,2	M 10	3/8"	
	RVSAE3/6DS-114-...	58,7	30,2	M 10	--- ¹⁾	
	RVSAE3/6DS-112-...	69,9	35,7	M 12	1/2"	
	RVSAE3/6DS-21-...	77,8	42,9	M 12	1/2"	
	RVSAE3DS-212-...	88,9	50,8	M12	1/2"	
6000 psi (420 bar)	RVSAE3/6DS-34-...	50,8	23,8	M 10	3/8"	
	RVSAE3/6DS-11-...	57,2	27,8	M 12	7/16"	
	RVSAE3/6DS-114-...	66,7	31,8	M 14	1/2"	
	RVSAE3/6DS-112-...	79,4	36,5	M 16	5/8"	
	RVSAE3/6DS-21-...	96,6	44,5	M 20	3/4"	
	RVSAE6DS-212-...	123,8	58,7	M 24	--- ²⁾	

¹⁾ RVSAE3/6-114... on a 3000 psi port, accepts M10 bolts only.

²⁾ RVSAE6DS-114... (6000 psi model) accepts M24 bolts only.

5.3 Minimum distance between 2 SAE check valves

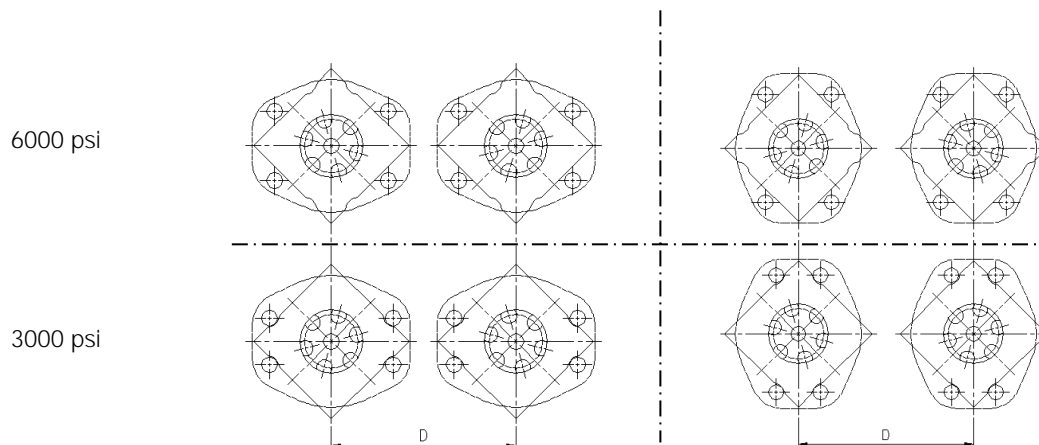

shorter distances on inquiry

		D _{min}
3000 psi (210 bar) and 6000 psi 420 (bar)	RVSAE3/6D-34-...	61,00
	RVSAE3/6DS-11-...	69,00
	RVSAE3/6DS-114-...	79,50
	RVSAE3/6DS-112-...	94,00
	RVSAE3/6DS-21-...	114,00
	RVSAE3DS-212-...	133,00
	RVSAE6DS-212-...	148,10

6 Performance graphs

measured with oil viscosity 33 mm²/s (cSt)

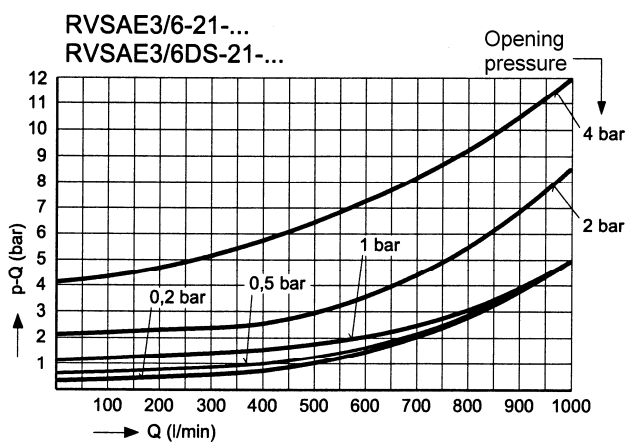
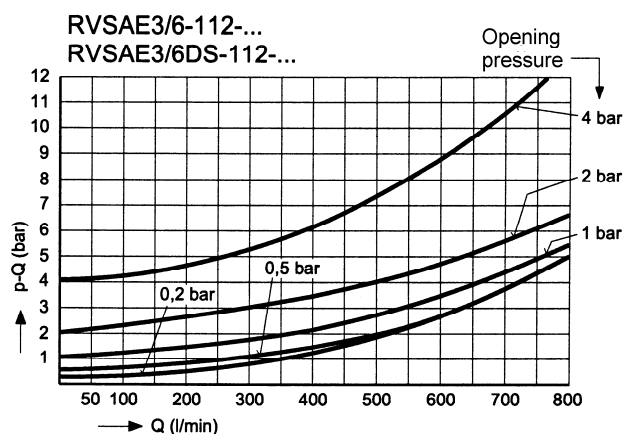
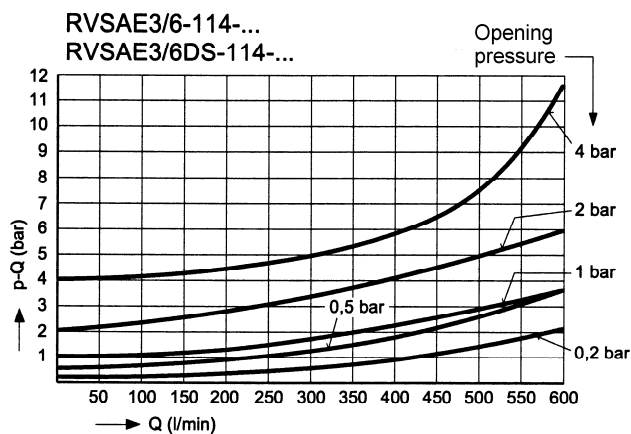
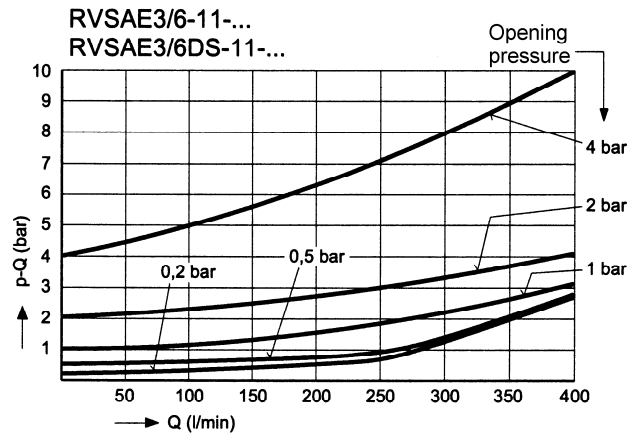
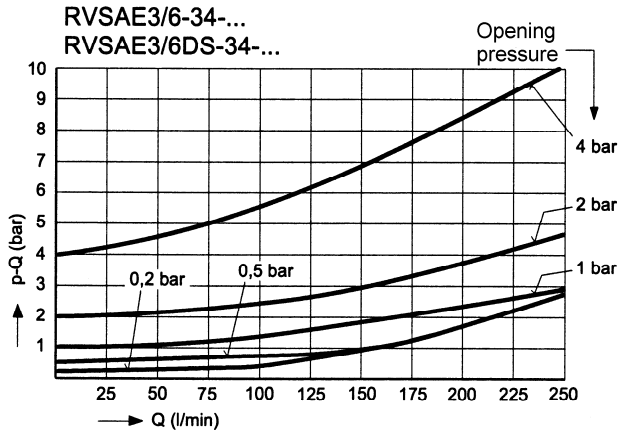

7 Ordering details

Model code key – check valve

	Ex.	RV	SAE	3/6	DS	-	-	-	-
Check valve		RV							
for SAE flange port (fits between port and flange)		SAE							
With dual-purpose body 3000 psi / 6000 psi		3/6							
For 3000 psi port (for size 212)		3							
For 6000 psi port (for size 212)		6							
O-rings on both faces		DS							
Inklusiv one insert plate		DSZ							
Nominal size									
3/4"		34							
1"		11							
1 1/4"		114							
1 1/2"		112							
2"		21							
2 1/2"		212							
Opening pressure									
0.2 bar		02							
0.5 bar		05							
1 bar		1							
2 bar		2							
4 bar		4							
Metering orifice									
Without orifice		(blank)							
With orifice (by consultation)		D1x...							
O-rings									
Nitrile (standard)		(blank)							
Viton		V							

Contact Bucher Hydraulics for further information on:

- other opening pressures
- special materials
- customised designs

Model code key – insert plate

	Ex.	ZPSAE	-	-
Insert plate for SAE check valve		ZPSAE		
Nominal size				
3/4"		34		
1"		11		
1 1/4"		114		
1 1/2"		112		
2"		21		
2 1/2" 3000 psi		212/3		
2 1/2" 6000 psi		212/6		

8 Design and installation notes

By turning them through 90°, the RVSAE3/6DS-... dual-purpose bodies and insert plates can be used on both 3000 psi and 6000 psi ports of the same nominal size (does not apply to the 2 ½" size).

Where an insert plate is added, it is seldom necessary to fit longer SAE

flange connecting bolts.

The installation dimensions and tolerances must be maintained.

Referring to the free-flow direction, nozzles and orifices must not be situated directly before the check valve (see Data Sheet 170-P-059000-E).

When fitting the valve, take particular care to ensure that the valve is firmly seated on the sealing surface, but that valve components are not deformed by the use of excessive force.

Use the specified tightening torque when fitting the SAE flange connecting bolts.

9 Application notes

The maximum operating pressure must not be exceeded and any pressure peaks must be taken into consideration.

The specified nominal flow rate must not be exceeded.

In applications such as accumulator circuits, where sudden pressure can be applied to the valve in the free-flow direction, ensure that the specified flow ratings are not exceeded.

Buyers bear the sole responsibility for ensuring that the selected products are suitable for their applications. Buyers normally establish this by undertaking qualification programs on test stands, or by evaluating the performance of prototype machines or systems.