

Technical manual BA 0419



Pressure

Precont TM pressure transmitter

for continuous measuring of absolute and relative pressures
in gases, steam, liquids and dusts

Pressure ranges from -1 to 60 bar

Ceramic highly overload resp. pressure blow resistive membrane

Various usability, especially for hygienic applications

Suitable for wide process temperature range from -40 °C to $+125$ °C

ATEX II 1/2 G Ex ia IIC T4 Ga/Gb resp. ATEX II 2 G Ex ib IIC T4 Gb

Certificated for the use in explosive hazardous areas

Shortest reaction time and excellent accuracy up to $\leq 0,1\%$

Integrated evaluation electronic in 2-wire-technology with signal 4...20mA

Integrated over voltage protection

ACS-CONTROL-SYSTEM
know how mit system



Lauterbachstr. 57 – 84307 Eggenfelden – Germany
Tel: +49 8721/9668-0 – Fax: +49 8721/9668-30
info@acs-controlsystem.de – www.acs-controlsystem.de

Index

Application	3
Function	3
Permissible pressure to the measurement membrane	4
Safety notes	5
Safety notes 	5
Installation	6
Maintenance	6
Electrical connection	7 / 8
Technical data	9 / 10
Dimension drawings	11
Order code overview	12

Application

The devices of series **Precont TM** with integrated analogue evaluation electronic are compact pressure transmitter for continuous measurement of pressures from –1 up to 60 bar in gases, vapors, liquids and dusts within closed container or pipelines, also in explosive hazardous areas, at process temperatures from – 40°C to +125°C.

The use of a capacitive measuring sensor with ceramic membrane, allows the use in nearly all fields of industry, especially also in hygienic applications.

Application fields are e.g. water, waste water, solvents, oil, sludge, fat, cleaning liquids, etc.

Function

The device is mounted into the wall of the pressure container or of the pipeline.

Characteristics of the ceramic measuring membrane

The system pressure is applied to the ceramic membrane and causes there a variation of the capacity at the back side of the membrane.

A pressure transmitting liquid is not used.

The ceramic membrane offers excellent characteristics like highest pressure and pressure blow strength up to forty times the nominal pressure, vacuum resistance, very high resistance against chemicals, corrosion and abrasion as well as very good insensitiveness against temperature shocks, highest accuracy and reproducibility, good long term stability and a very low temperature influence.

Characteristics of the temperature decoupler – type H

The temperature decoupler is mounted between the pressure recording measuring membrane and the integrated transmitter electronic and reduces by this the heat transfer from the process to the transmitter electronic.

This leads among others to a extension of the permissible medium temperature of – 40 to +125°C and to an essential increase of the temperature stability of the device.

Signal processing

The pressure signal of the ceramic membrane is measured by the integrated analogue electronic and converted in a output current signal of 4...20mA.

The measurement signal range is adjusted by factory in many standard measurement ranges. A factory provided adjustment by customer specification is also possible.

Integrated over voltage protection components prevents the device from destruction by atmospheric influences like e.g. thunderstrike.

Permissible pressure to the measuring membrane

measurement range	vacuum	overload / burst pressure
0...100 mbar _{rel}	0,7 bar _{abs}	+4 bar _{rel}
0...200 mbar _{rel}	0,5 bar _{abs}	+6 bar _{rel}
0...400 mbar _{rel}	0 bar _{abs}	+6 bar _{rel}
0...600 mbar _{rel}	0 bar _{abs}	+10 bar _{rel}
0...1000 mbar _{rel}	0 bar _{abs}	+10 bar _{rel}
0...1600 mbar _{rel}	0 bar _{abs}	+18 bar _{rel}
0...2500 mbar _{rel}	0 bar _{abs}	+25 bar _{rel}
0...4000 mbar _{rel}	0 bar _{abs}	+25 bar _{rel}
0...6000 mbar _{rel}	0 bar _{abs}	+40 bar _{rel}
0...10000 mbar _{rel}	0 bar _{abs}	+40 bar _{rel}
0...16000 mbar _{rel}	0 bar _{abs}	+40 bar _{rel}
0...20000 mbar _{rel}	0 bar _{abs}	+40 bar _{rel}
0...25000 mbar _{rel}	0 bar _{abs}	+40 bar _{rel}
0...40000 mbar _{rel}	0 bar _{abs}	+60 bar _{rel}
0...60000 mbar _{rel}	0 bar _{abs}	+105 bar _{rel}
-100...0 mbar _{rel}	0,7 bar _{abs}	+4 bar _{rel}
-100...+100 mbar _{rel}	0,5 bar _{abs}	+6 bar _{rel}
-1000...0 mbar _{rel}	0 bar _{abs}	+10 bar _{rel}
-1000...+1000 mbar _{rel}	0 bar _{abs}	+18 bar _{rel}
-1000...+9000 mbar _{rel}	0 bar _{abs}	+40 bar _{rel}
0...100 mbar _{abs}	0 bar _{abs}	+4 bar _{abs}
0...200 mbar _{abs}	0 bar _{abs}	+6 bar _{abs}
0...400 mbar _{abs}	0 bar _{abs}	+6 bar _{abs}
0...600 mbar _{abs}	0 bar _{abs}	+10 bar _{abs}
0...1000 mbar _{abs}	0 bar _{abs}	+10 bar _{abs}
0...1600 mbar _{abs}	0 bar _{abs}	+18 bar _{abs}
0...2500 mbar _{abs}	0 bar _{abs}	+25 bar _{abs}
0...4000 mbar _{abs}	0 bar _{abs}	+25 bar _{abs}
0...6000 mbar _{abs}	0 bar _{abs}	+40 bar _{abs}
0...10000 mbar _{abs}	0 bar _{abs}	+40 bar _{abs}
0...16000 mbar _{abs}	0 bar _{abs}	+40 bar _{abs}
0...20000 mbar _{abs}	0 bar _{abs}	+40 bar _{abs}
0...25000 mbar _{abs}	0 bar _{abs}	+40 bar _{abs}
0...40000 mbar _{abs}	0 bar _{abs}	+60 bar _{abs}
0...60000 mbar _{abs}	0 bar _{abs}	+105 bar _{abs}

Safety notes

Each person that is engaged with inauguration and operation of this device, must have read and understood this technical manual and especially the safety notes.



Installation, electrical connection, inauguration and operation of the device must be made by a qualified employee according to the informations in this technical manual and the relevant standards and rules.

The device may only be used within the permitted operation limits that are listed in this technical manual. Every use besides these limits as agreed can lead to serious dangers.

The materials of the device must be chosen resp. checked for suitability to the respective application requirements (contacting substances, process temperature). An unsuitable material can lead to damage, abnormal behavior or destruction of the device and to the resulting dangers.

The device may not be used as sole measure for prevention of dangerous conditions in machines and plants.

This device is conform to article 3 (3) of the EC directive 97/23/EC (pressure equipment device directive) and is designed and produced in good engineer practice.

The device meets the legal requirements of all relevant EC directives.  **0158**

**Safety notes for electrical operating supplies for explosive hazardous areas**

If a device is installed and operated in explosive hazardous areas, the general Ex construction standards (EN60079-14, VDE0165), this safety notes and the enclosed EC conformity certificate must be observed. The installation of explosive hazardous systems must be carried out principally by specialist staff.

The device meets the classification:

II 1/2 G Ex ia IIC T4 Ga/Gb

II 2 G Ex ib IIC T4 Gb

The devices are conceived for measurement of pressures in explosive hazardous areas.

The measured medium may also be combustible liquids, gases, fogs or steams.

The permitted operating temperatures and pressures are type and variant dependent and can be found in this technical manual.

For applications, which require devices of category 1/2, the process pressure and temperature range of the media has to be between 0,8 bar and 1,1 bar and between -20 °C and 60 °C.

The device with over voltage protection Precont Ex1TM_ _B... is earthen for safe technical function. Provide sufficient potential compensation along the complete cable way.

Install the intrinsically safe circuit earth free.

At variants of the devices with chargeable plastic parts (e.g. cable), a warning marking points out to the safety measures, that must be applied because of the electrostatic charging in operation and especially in the case of maintenance activities.

avoid friction - no dry cleaning - no assembling in pneumatic conveying stream

Installation

The installation of the device at locations where high pressure blows can occur should be avoided.

The installation of the device should be made if possible at temperature calmed places to get a reliable measuring result. Large temperature steps, e.g. at filling of a hot medium into a cold system, can produce a short-time higher measuring signal deviation. The deviation will be completely neutralized after the adaptation of the measuring membrane of the pressure transmitter to the temperature.

At a step from +20°C ...+80°C this neutralization can wile up to 3 minutes.

Drive the system pressure free prior installation resp. deinstallation of the sensor.

The tightening of the process connection with screw-in thread may only be done at the hexagon by a suitable spanner. The maximum permitted torque strength is 50 Nm.

The screw in of the process connection by using the housing tube, the connection plug resp. the connection cable is not permitted.

Avoid the pollution of the pressure compensation hole at the version with plug M12x1 resp. of the pressure compensation element at the version with plug DIN EN 175-301-803 resp. of the pressure compensation capillary at the version with connected cable.

The hindrance of the pressure compensation can lead to faulty measuring results.

The pressure compensation is made at the version:

- S – plug acc. to DIN EN 175-301-803-A by the plug socket
- V – plug M12x1 by the drill hole besides the plug
- K – connected cable by the capillary inside the cable

At the version with connected cable, the environmental air pressure is supplied to the measurement membrane of the probe by an integrated pressure compensation capillary. This capillary may not be folded or sealed. To avoid faulting, a micro air filter is placed at the end of the capillary.

In the case of an application conditioned cutting of the connected cable there must be especially paid attention that this micro air filter will be replaced to the end of the capillary after the cutting.

The correct function of the device within the specific technical data can only be guaranteed, if the permitted temperature (see technical data) in the area of the housing tube will not be exceeded.

This can be achieved by the using of the temperature decoupler or also by isolation of the medium carrying part of the plant or by other constructive measures to reduce the transferring of an extreme temperature to the housing tube.

Maintenance

The device is free of maintenance.

Special substances can lead to solid coatings on the membrane.

Such depositions can lead to faulty measurement results of the device.

In the case of coat forming liquids the membrane must be regularly cleaned e.g. with clear water.

Don't use sharp tools or aggressive chemicals for cleaning.

Repair

A repair may only be carried out by the manufacturer.

If the device must be sent back for repair, the following informations must be enclosed:

- An exact description of the application.
- The chemical and physical characteristics of the product.
- A short description of the occurred error.

Before returning the device for repair, the following measures must be proceeded:

- All stick product residues must be removed. This is especially important, if the product is unhealthily, e.g. caustic, toxic, carcinogenic, radioactive etc.
- A returning must be refrained, if it is not possible by 100% to remove the unhealthily product completely, because e.g. it is penetrate into cracks or is diffused through plastic.

Electrical connection

The electrical connection of the device must be carried out according to the respective country specific standards.

Incorrect installation or adjustment could cause applicationally conditioned risks.

Use only twisted shielded signal and measurement wires and install these wires separated from power leading wires. Connect the cable shield only at one side to earth, ideally at the installation place of the device.

The metallic parts of the device (process connection, housing tube) are electrically connected with the terminal PE of the plug DIN EN 175-301-803-A, with the socket of the plug M12x1 or with the cable shield of the version with connected cable.

Due to this the earth connection can be carried out by the process connection.

The voltage applied to the plug contacts may not exceed 45 V, to avoid damage of the electronic.

All connections are polarity protected.

A load, e.g. the measuring shunt of an evaluation device, in series with a device with 4...20 mA current signal in 2-wire-technology reduces the supply voltage available at the device. This results in a maximum value for this resistor, where a correct function is still possible.

The maximum load at signal current 20mA can be calculated by the equation:

$$R_L \text{ max} = (V_S - 11,5V) / 20\text{mA} \text{ with } V_S = \text{applying supply voltage.}$$

For inauguration it is suggested, to deactivate all connected control devices, to avoid unwanted control reactions.

Terminal assignment

**plug (socket)
DIN EN 175-301-803
style A**

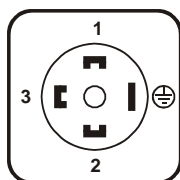

Pin 1 signal +
Pin 2 signal -
Pin 3 not connected

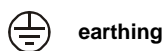

**plug (socket)
M12x1**



Pin 1 signal +
Pin 2 not connected
Pin 3 signal -
Pin 4 not connected

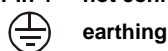

connected cable

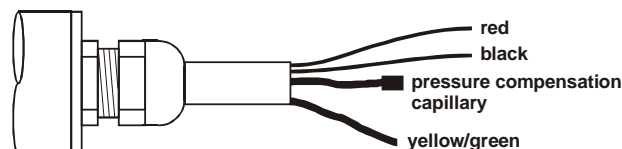

red signal +
black signal -

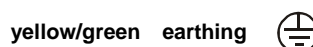

Electrical connection – non explosive hazardous area

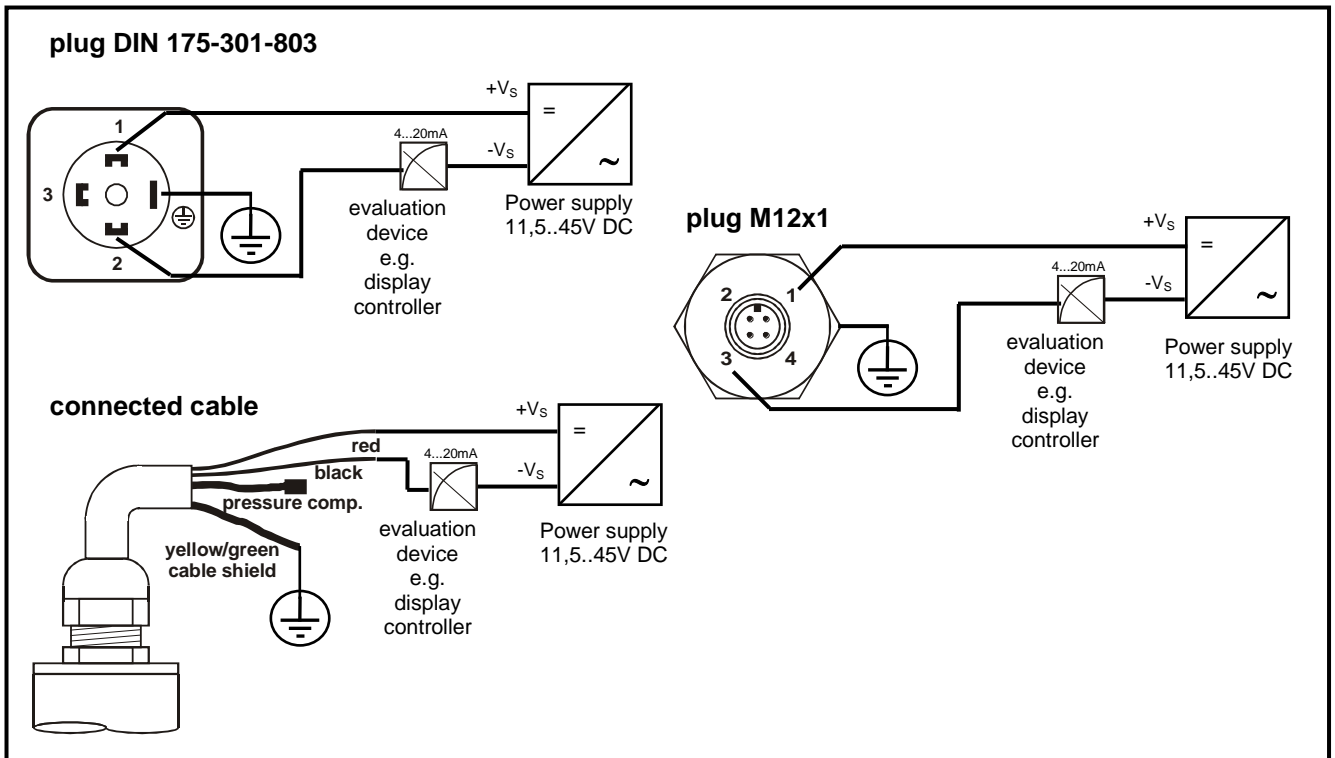

Electrical connection – explosive hazardous area

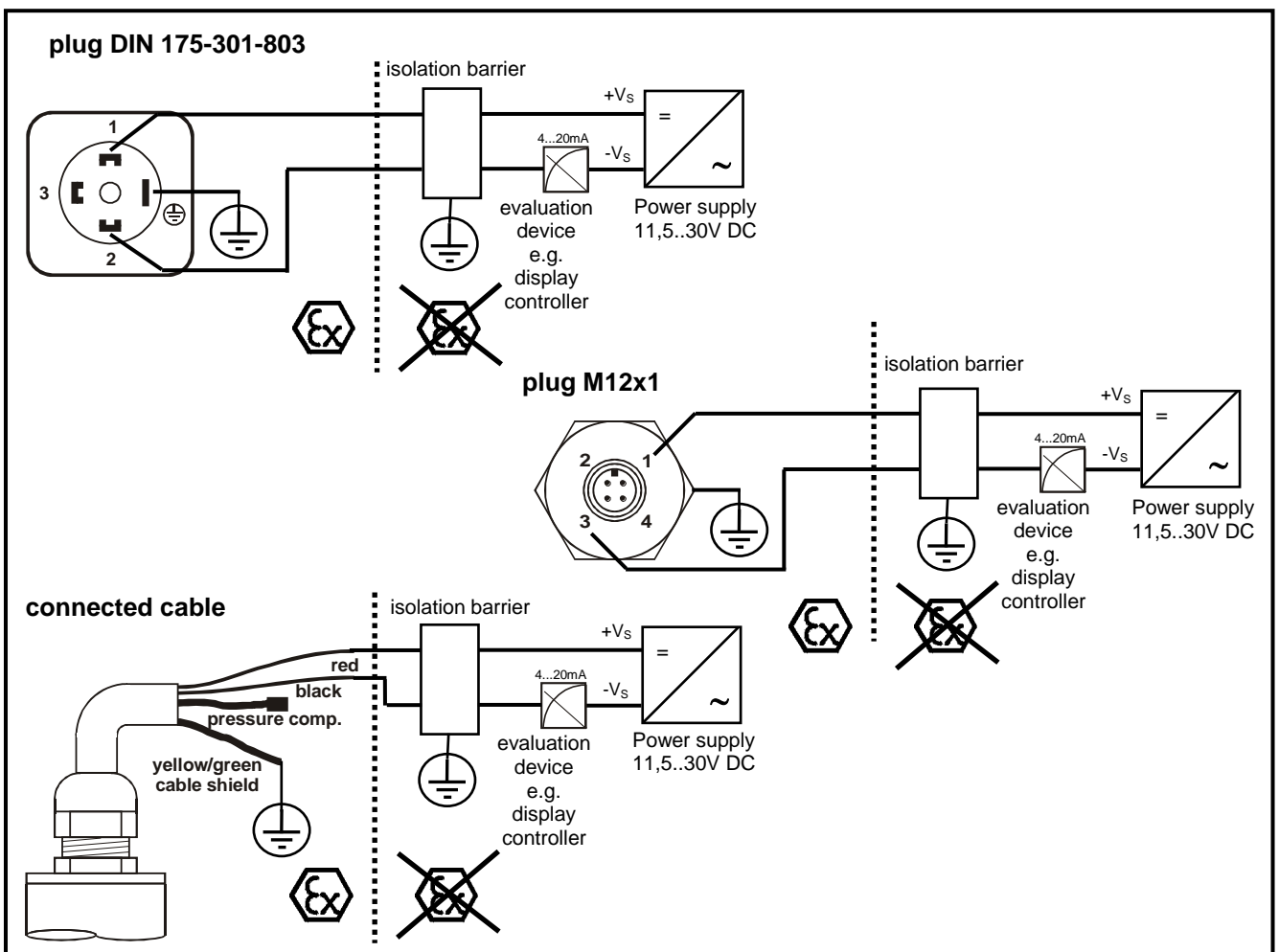

Technical data**Auxiliary supply**

Supply voltage:	reverse polarity protected 11,5 to 45 V DC	for Ex-variant 11,5 V to 30 V DC
Ripple voltage:	$\leq 2 V_{PP}$	condition: within the permitted supply voltage range

Signal output 4...20mA

Signal type:	linear characteristic from ≤ 4 mA resp. ≥ 20 mA, minimum 2,75 mA \pm 0,75 mA / maximum 27 mA	
Permitted load:	$R_L \text{ max} = (V_S - 11,5V) / 20\text{mA}$	
Characteristic deviation ^{3) 5) 12)} :	$\leq 0,1\%$ resp. $0,2\%$ FS ²⁾	
Nonlinearity ¹²⁾ :	$\leq \pm 0,1\%$ / $0,2\%$ FS ²⁾	
Hysteresis ¹²⁾ :	negligible	
Long term deviation ¹²⁾ :	$\leq \pm 0,1\%$ FS ²⁾ / year not cumulative	
Temperature deviation ¹²⁾ :	T_k ⁴⁾ Zero	$\leq \pm 0,10\%$ FS ²⁾ / 10 K, max. $\pm 0,75\%$ FS ²⁾ (-20...+80°C)
	T_k ⁴⁾ Span	$\leq \pm 0,10\%$ FS ²⁾ / 10 K, max. $\pm 0,5\%$ FS ²⁾ (-20...+80°C) max. $\pm 0,8\%$ FS ²⁾ ($\leq 0..0,4$ bar) (-20...+80°C) besides -20...+80°C with factor 2 for T_k
Influence of supply voltage:	$\leq \pm 0,01\%$ FS ²⁾ / 10V	
Minimum delay time:	≤ 2 ms	

Mounting position

Maximum deviation ¹⁰⁾ :	$\leq 0,18$ mbar
------------------------------------	------------------

Over voltage protection

Category:	not available for Ex-variant Ex0TM coarse protection / fine protection
Signal voltage:	max. 30V peak value, to PE connection
Nominal bypass surge current:	10 000 A – wave 8/20 μ s
Trigger voltage:	90V coarse protection 33V fine protection

²⁾ Referring to nominal measuring span resp. full scale (FS)

³⁾ Nonlinearity + Hysteresis + Reproducibility

⁴⁾ T_k = Temperature coefficient

⁵⁾ At limit value adjustment

¹⁰⁾ Device rotated by 180°, process connection upside.

¹²⁾ Higher values for special measuring range

Technical data**Materials**

Membrane: (medium contact)	Ceramic AL ₂ O ₃ 99,9% at process connection 8/9/R >> ceramic AL ₂ O ₃ 96%
Process connection: (medium contact)	Steel 1.4404 (AISI 316L) / 1.4571 (AISI 316Ti)
Temperature decoupler:	CrNi-steel
Housing tube:	CrNi-steel
Device plug:	<i>DIN EN 175-301-803-A</i> housing PA polyamide, contacts tinned, gasket NBR <i>M12x1</i> socket CrNi-steel, insert PUR, contacts gold-plated
Connected cable:	<i>cab</i> cable sheath – PE polyethylene <i>cab gland</i> housing – PA polyamide, gasket – CR / NBR
Pressure compens. element:	PTFE
Gaskets:	medium contact → FPM – fluorelastomere (Viton®) EPDM – etylene-propylene-dienmonomere CR – chloroprene-rubber (Neopren®) FFKM – perfluorelastomere (Kalrez®) others → FPM – fluorelastomere (Viton®)

Environmental conditions

Environmental temperature: – 20°C...+85°C, limitation at Ex variants

Limitation by variant	Environmental temperature range
Connected cable	-20...+70°C

Process temperatures: – 20°C...+100°C, limitation at Ex variants

Extension by variant	Process temperature range
Temperature decoupler – type H	-40...+125°C
Limitation by material	Process temperature range
Gasket FPM	-25...+125°C
Gasket CR	-40...+120°C
Gasket FFKM	-15...+125°C

Process pressure ranges: depends on variant, maximum – 1 bar ...60 bar

Vacuum- / overload resistance: depends on meas. range, see table perm. pressure to the membrane

Weight: depends on variant

Protection classification: *Variant plug acc. to DIN 175-301-803*

IP65 DIN EN 60529

Variant plug M12x1 and variant connected cable

IP68 / 1mH₂O for 1h DIN EN 60529

Climatic classification: 4K4H DIN EN 60721-3-4

Shock classification: 50 g / 11 ms DIN EN 60068-2-27

Vibration classification: 20 g / 10 – 2000 Hz DIN EN 60068-2-6

EM – compatibility: emission DIN EN 61326-1 operation device class B

immunity DIN EN 61326-1 industrial range

Reference conditions: DIN EN 60770-1

T = 25 °C, relative humidity 45...75 %,
environmental air pressure 860...1060 kPa

Dimension drawing

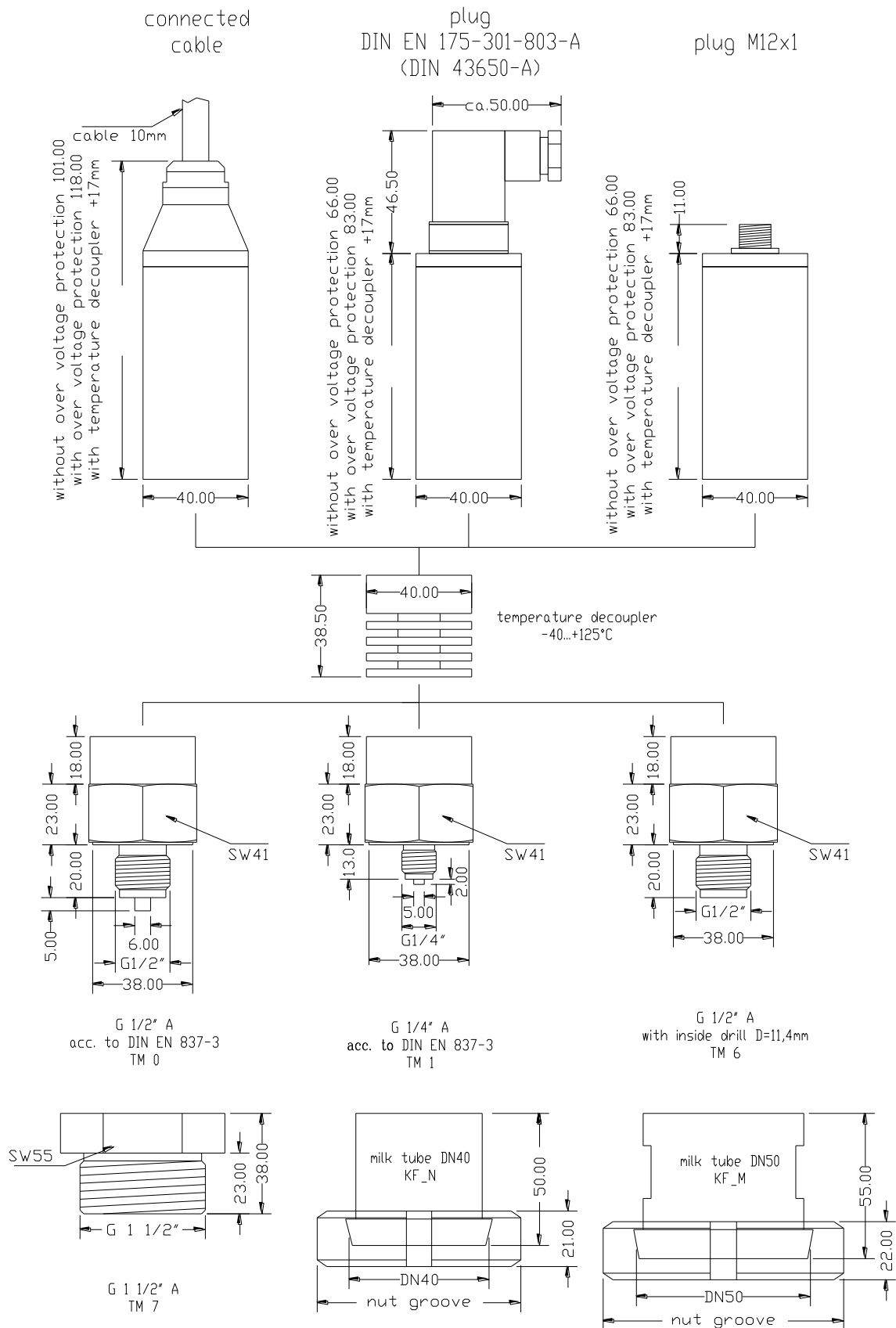

Order codeType:

TM Standard
 Ex0TM ATEX II 1/2 G Ex ia IIC T4 Ga/Gb
 Ex1TM ATEX II 2 G Ex ib IIC T4 Gb

Process connection:

0	G 1/2" A	DIN EN ISO228-1	DIN EN 837-3	manometer (formerly DIN 16288)	
1	G 1/4" A	DIN EN ISO228-1	DIN EN 837-3	manometer (formerly DIN 16288)	
6	G 1/2" A	DIN EN ISO228-1		inside drill 11,4 mm	
7	G 1 1/2" A	DIN EN ISO228-1		front flush membrane	
8	G 3/4" A	DIN EN ISO228-1	≤20 bar	front flush membrane	measuring membrane AL ₂ O ₃ 96%
9	G 1/2" B	DIN EN ISO228-1	≤20 bar	front flush membrane	measuring membrane AL ₂ O ₃ 96%
R	Milk tube	DN 25, PN 40	DIN 11851	≤20 bar	measuring membrane AL ₂ O ₃ 96%
N	Milk tube	DN 40, PN 40	DIN 11851		
M	Milk tube	DN 50, PN 25	DIN 11851		
Y	others on request				

Electronic – output:

A 2-wire-technology signal 4...20 mA

Material process connection (medium contact):

V Steel 1.4404 (AISI 316L) / 1.4571 (AISI 316Ti)

Over voltage protection:

B with over voltage protection not for type Ex0TM
 0 without over voltage protection

Measuring range:

01	0...0,1 bar	11	0...16 bar
02	0...0,2 bar	12	0...25 bar
03	0...0,4 bar	13	0...40 bar
04	0...0,6 bar	14	0...60 bar
05	0...1 bar	15	-0,1...0 bar
06	0...1,6 bar	16	-1...0 bar
07	0...2,5 bar	17	-1...+1 bar
08	0...4 bar	18	-0,1...+0,1 bar
09	0...6 bar	19	-1...+9 bar
10	0...10 bar	YY	special measuring range separate spec. necessary

Gaskets (medium contact):

1	FPM	fluorelastomere (Viton®)	
2	CR	chloroprene-rubber (Neopren®)	
3	EPDM	etylene-propylene-dienmonomere	for food applications
4	FFKM	perfluorelastomere (Kalrez®)	
6	FFKM	perfluorelastomere high density	for gas applications

Process temperature:

0 Standard -20°C to +100°C
 H Extended -40°C to +125°C with temperature decoupler

Pressure type:

R Relative pressure
 A Absolute pressure

Accuracy measuring system¹⁾ – material measuring membrane (medium contact):

1	0,2%	ceramic AL ₂ O ₃	99,9%
		at process connection 8/9/R >>	ceramic AL ₂ O ₃ 96%
3	0,1%	Linearization protocol	ceramic AL ₂ O ₃ 99,9%
		at process connection 8/9/R >>	ceramic AL ₂ O ₃ 96%

Electrical connection:

S Plug acc. to DIN EN 175-301-803-A (formerly DIN 43650-A)
 V Plug M12x1
 K Connected cable, from 1,5m

Precont _ _ **A V** _ _ _ _ _

Installation material and connection cable are not enclosed in the delivery contents.

¹⁾ Higher values for special measuring range