

<hr/> <h1 style="margin: 0;">Specifications</h1> <hr/>	
Product No. :	
Product Name :	<u>MSS*XP Series</u>
Published Date: August 2, 1999	
Revised Date :	

Received by:

I received this document on:
Date:

FA ENGINEERING DEPARTMENT
INDUSTRIAL AND APPLIANCE MOTOR DIVISION
MOTOR COMPANY
MATSUSHITA ELECTRIC INDUSTRIAL CO., LTD.
7-1-1, MOROFUKU, DAITO, OSAKA, 574-0044 JAPAN
TEL 0720-71-1212
FAX 0720-70-3151

Responsible Person in Department	Responsible Person in Section	Approval Stamp	Person in Charge
<i>H. Zame</i>	<i>K. Takada</i>	<i>S. Nakano</i>	<i>K. Ishimoto</i>

Published Date: August 2, 1999	Specifications	Responsible Person in Section	Approval Stamp	Person in Charge
Revised Date:		<i>K. Tokuda</i>	<i>N. Nakamura</i>	<i>K. Shimoto</i>

1. Applicability

This specification relates to a position driver section of AC servo system which consists of an AC servo motor and a position driver that drives the same motor manufactured and delivered by Industrial and Appliance Motor Division of Matsushita Electric Industrial Co., Ltd.

2. Introduction

2-1 After opening the package

Driver		Applicable Motor			
Product No.	Model No.	Rated Output	Voltage Specifications	Rated Speed	Encoder Pulses
MSS3A1 A1XP	MSM3AZA**	30 W	100/200 V	3000 r/min	10-Line 2500P/r
MSS5A1 A1XP	MSM5AZA**	50 W	100/200 V	3000 r/min	10-Line 2500P/r
MSS011 A1XP	MSM011A**	100 W	100 V	3000 r/min	10-Line 2500P/r
MSS021 A1XP	MSM021A**	200 W	100 V	3000 r/min	10-Line 2500P/r
MSS041 A1XP	MSM041A**	400 W	100 V	3000 r/min	10-Line 2500P/r
MSS3A3 A1XP	MSM3A3A**	30 W	100/200 V	3000 r/min	10-Line 2500P/r
MSS5A3 A1XP	MSM5A3A**	50 W	100/200 V	3000 r/min	10-Line 2500P/r
MSS013A1XP	MSMD012A**	100 W	200 V	3000 r/min	10-Line 2500P/r
MSS023A1XP	MSMD022A**	200 W	200 V	3000 r/min	10-Line 2500P/r
MSS043A1XP	MSMD042A**	400 W	200 V	3000 r/min	10-Line 2500P/r
MSS083A1XP	MSMD082A**	750 W	200 V	3000 r/min	10-Line 2500P/r

2-2 Model symbols

Model symbols can be read in the following method

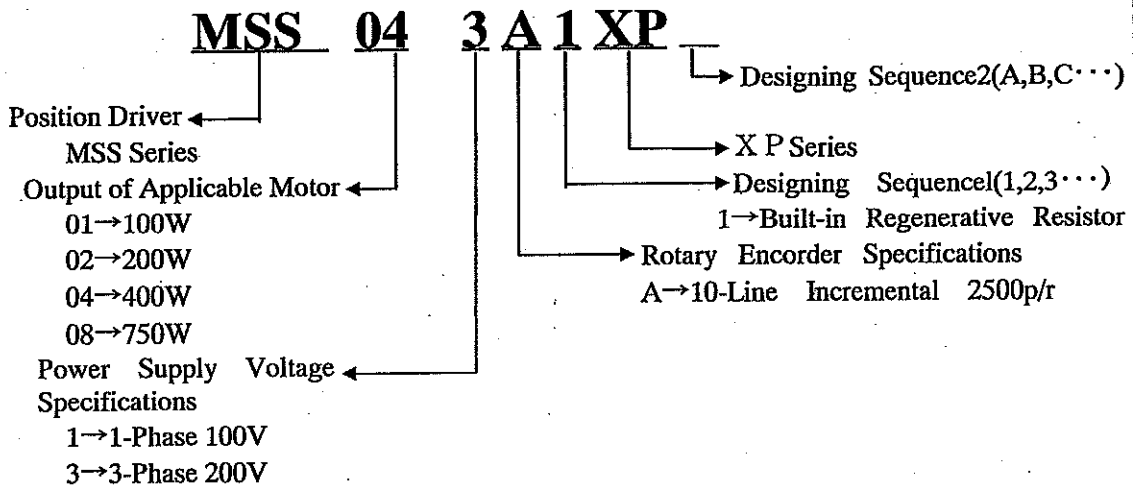

2-3 Outside Dimensions

According to Dimensional Outline drawings (SR-DSV789601)

(SR-DSV789602)

(SR-DSV789603)

3. Appearance and Each Part Name

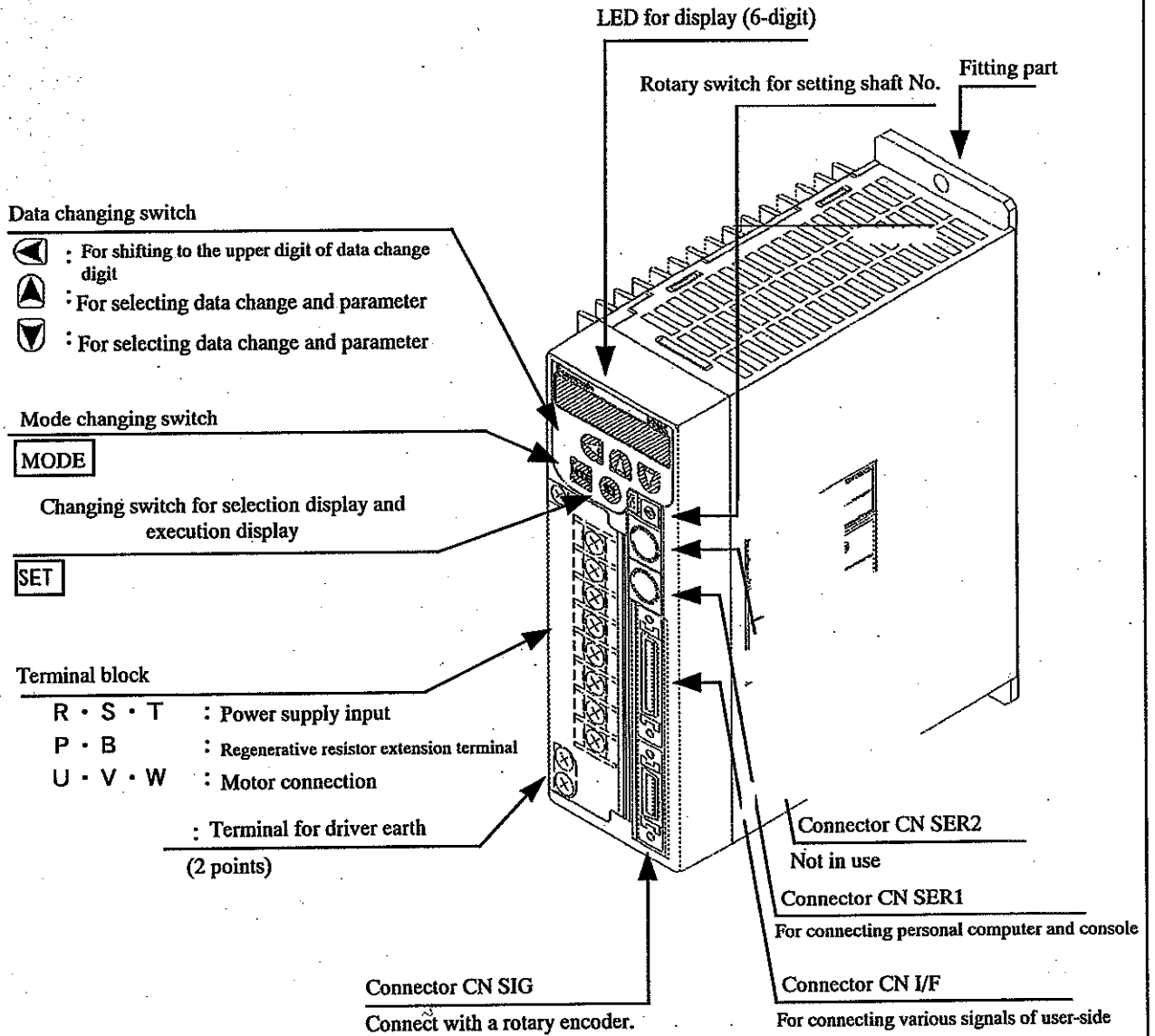

4 Notices in use

Be sure to keep the following to prevent electric shock and injuries.

4-1 Cautions for safety

- (1) Never touch the inside of the position driver during its run as the high-voltage circuit is in the driver. If the overhaul is necessary, request it to our company or other agents designated by us.
- (2) After turning the power supply off, the inside of the circuit is still charged with high voltage for a while. If you'd like to touch the terminals of the terminal board and the inside of the position driver, cut the power supply input completely outside the position driver and wait for 5 minutes or longer.
- (3) Do not touch the position driver, the motor and the peripheral equipment during the power-state as temperature of these units becomes high. Especially when using the regenerative resistor of an option, as the regenerative resistor may become quite high in the temperature, do not put combustibles near the resistor.
- (4) During turning the power supply on, keep enough distance from the motor and the machine driven by it in case of the malfunction.
- (5) Never touch the rotating part of the motor during its run.
- (6) Since temperature for the position driver radiator, the regenerative resistor and the motor are very high for a while even after cutting the power supply, do not touch these units.
- (7) When an alarm is generated, remove the cause to assure the safety and restart after the alarm reset.
- (8) As there may be sudden restart after turning the power supply on again with a instant stop, do not get close to the machine.
- (9) If you don't use for a long time, be sure to turn the power supply off.
- (10) Capacitor of the power supply rectification circuit will lower the capacity due to the aging. We recommend it be exchanged approximately after 5 years to prevent the secondary accident against the troubles.

Panasonic driver is designed and manufactured through the highest quality control however, unexpectedly higher external noise, applying high-static electricity, and any trouble of part and terminal wiring may cause an abnormal operation. Please pay extra attention for the safety of your machine.

- (11) For wiring, use a breaker according to section 6-1-1 "Wiring to the terminal block"(Page 8).

- ◆ Setting and installation of the equipment should be done securely in consideration of an unexpected earthquake.
- ◆ After having an earthquake, be sure to check on the safety.

4-2 In order to use the driver properly

- ◆ Since an incorrect use of the driver may lead to an abnormal operation, or may damage the position driver in the worst case, carefully read the following cautions to operate properly.
- ◆ Read this manual thoroughly for the proper operation. Always keep this manual beside the machine and read it again when you have questions.

- (1) Do not apply voltage higher than the allowable range to the power supply input terminals (R,S, T).
- (2) Do not connect the power supply to other terminals than the power supply input terminals (R,S,T) in any case. For wiring, refer to section 6-1-1 "Wiring to the terminal block " (Page 8).
- (3) The input power side is capacitor input type. When you turn the power supply on, highly-charged current will run and there may be a great voltage drop because of the power supply impedance.
We recommend you to use an independent power supply for the position driver.
- (4) For the power supply capacity, refer to section 6-2 "Wiring device selection" (P. 20).
- (5) Install at ambient temperature of 0°C - 50°C. If the temperature exceeds this range, it may be a cause of malfunction or failure.
- (6) Do not perform pressure proof test (dielectric strength test) or megger test.
(When you perform these tests for an external circuit, pull out all front terminals of the position driver and the connector so that no test voltage may be applied to the position driver.)
- (7) Do not perform a overload operation for the motor and the position driver, not in the ability range (Such as continuous overcurrent operation).
- (8) After turning the power supply off, keep an interval about 6 to 11 seconds before turning it on again. If this interval is short, it may not start up normally because its internal circuit is not initialized.
- (9) If you use a leakage current breaker, use it especially made for "Inverter" with high-frequency ability.
- (10) Use the motor and the position driver in the designated combination.
- (11) After checking that the input voltage is in accordance with the position driver specifications, turn the power supply on and operate. If voltage above the rating is input, an accident with fire or smoke may be generated inside the position driver, leading to a cause of abnormal operation and burning for the motor.
- (12) For the trial run, fix the motor, and install to the machine after confirming the operation under the condition that the machine system is separated. There is a possibility of being injured.
- (13) Since the retaining brake is used for position retention of the machine, do not use it as a stopping device to obtain the machine safety. There is a possibility of being injured.
- (14) As an extreme adjusting change will make the operation unstable, do not conduct it. There is a possibility of being injured.

4-3 Notices on setting and storing

- ◆ For carrying, treat the position driver carefully to prevent its breakage. Do not grasp the cable and the motor shaft when carrying.
- ◆ Do not apply excessive force to the front panel and side plates of the position driver.

- (1) For the servo motor, high frequency switching current is applied and leak current exists under the situation. To release the leak current, be sure to connect the driver earth terminal (⊕) and the motor earth terminal (⊕), and then earth at one position. Also, earth the machine main unit. Class 3 Earthing (Under 100 Ω, φ 1.6mm and above) is recommended for preventing electric shock and malfunction. In case of using the earth leakage breaker, use one provided with high-frequency ability as "for inverter."
 - (2) This position driver is of vertical installation type. Be sure to keep the fitting direction.
 - (3) Install to noncombustibles such as metal.
 - (4) Install appropriately, matching with the output and the main unit weight.
 - (5) This position driver is not of water-proof structure. Do not use the driver outside.
 - (6) Do not get on or put a heavy matter on it.
 - (7) Do not block the intake/outlet port, and try not to take foreign matter in.
 - (8) Perform the wiring correctly and securely. Incorrect and insecure wiring will be a cause of abnormal operation and burning for the motor.
 - (9) Do not harm the cable, apply excessive stress to it, put a heavy matter on it.
- (10) Set the emergency stop circuit externally, enabling stopping the operation immediately and cutting the power supply.
- (11) Never store, install and use the driver at places where vibration and shock of 4.9m/s² or more are applied; there are much metal powder and dust; there are water, oil and grinding fluid splash; there are combustibles nearby; and corrosive gases and inflammable gases are generated. Also, do not use continuously at the resonance point.
 - (12) Do not apply a strong shock.

- (13) Be careful not to be affected by radiation. Heat generated at the position driver control part and heat by the motor current with the motor operation are added. If the position driver is used, storing in the enclosed control box, temperature in the control box may increase abnormally. In case of operating with the driver installed in the control box, pay attention to the cooling to lower the position driver's ambient temperature under the maximum ambient temperature. Try to keep specified distance between the main unit and the inside of the control board or other equipment.

Ambient temperature of the position driver

Life time of the position driver is greatly influenced by the ambient temperature.

Check that ambient temperature of 5cm around the position driver does not exceed the maximum ambient temperature.

Ambient temperature: 0°C - 50°C

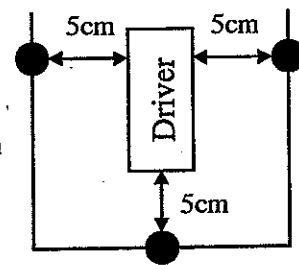

- (14) Do not install near heating elements such as heaters and large-size wire wound resistor. When such installation is unavoidable in terms of mounting and installing conditions, provide a thermal shield etc. between the position driver and the heating elements, not to be affected by such heating elements.
- (15) Do not store in the place where water, splash, harmful gas and liquid are found.
- (16) Store it in the place where it isn't exposed to the direct sunlight and within the designated temperature/humidity range.
- (17) In case the the time stored is quite long, please contact the store where you purchased or the reference indicated in this manual.
- (18) As an overload of the product may be a cause of load shifting, follow the instructions.

5 Installation Place

(1) This driver is the vertical installation type.

For the installation, fit it vertically and have sufficient space for the ventilation around it.

- ◆ When installing, firmly fit the position driver with screws and bolts without applying stress such as bending and twisting to the position driver main unit.
- ◆ For fitting screws and bolts, use size M4 or M5.
- ◆ For the fitting pitch, refer to the dimensional outline drawing.

(2) Do not install at places with high temperature, high humidity, or in the atmosphere with much dust, dirt, iron powder and chip.

(3) Install at places of ambient temperature 0°C - 50°C.

(4) Avoid places exposed with direct sunlight.

(5) Install at places not affected by corrosive gases and grinding fluid.

(6) This unit is not of the dust proof structure.

(7) Do not use outside. Install at places without vibration.
Do not use continuously at the resonance point.

6 Wiring

6-1 Notices in wiring

6-1-1 Wiring to the terminal block

- (1) As the terminal block cover is fixed by screws when wiring to the terminal block, release the screws and open the cover.
- (2) Securely wire according to Fig 6-1 "Wiring to the terminal block".
- (3) With regard to devices for wiring and electric wires to be used, etc., refer to 6-2 "Wiring device selection" (Page 14).
- (4) For power supply voltage, apply voltage indicated on the name plate.
- (5) Do not connect reversely the power input terminals (R,S,T) and the motor output terminals (U,V,W).
- (6) Do not ground or short-circuit the motor output terminals (U,V,W) mutually.

Note) Earth terminal (⊕) has a structure that it will be connected to the frame separately with the terminal block. Incorrect connection of the earth cable to the terminal block may damage the driver.

- (7) Usually, do not connect anything to the terminals (P,B). Also, do not touch the terminals (P,B) as high-voltage is applied when turning the power supply on. If absorbing capacity of regenerative energy is insufficient in some cases, consult with the store where you purchased.
- (8) Unlike an induction motor, in AC servo motor, rotation direction cannot be changed by exchanging the 3-phase. Wire as shown in Fig. 6-1.
- (9) For connecting the terminal block to each terminal, be sure to use a crimp-style terminal with insulation coating.
- (10) Securely connect the connector motor earth terminal (⊕) and the driver earth terminal (⊕), and earth to one point together with the noise filter earth terminal. Earthing the machine main unit is recommended. Earth in Class 3 Earthing. (Earthing resistance under 100 Ω, φ 1.6mm and above)
- (11) After finishing wiring to the terminal block, close the terminal block cover and fix with screws to prevent electric shock.
- (12) Provide the surge absorbing circuit to electromagnetic contactor, between relay contact points, coil and brake winding of a motor with a brake which are allocated around the position driver, for preventing error operation.
- (13) Provide a no-fuse breaker to securely cut the power supply outside the position driver in the emergency. In case of using a earth leakage breaker, use the one provided with high-frequency ability as "for inverter." Capacitor rush current protection circuit is not provided in the position driver power supply input circuit.
- (11) Provide a noise filter for reducing radio noise and preventing error operation. (Ex. LF-200, LF-300 Series made by Tokin Corporation)

After wiring, check again for error wiring before turning the power supply on.

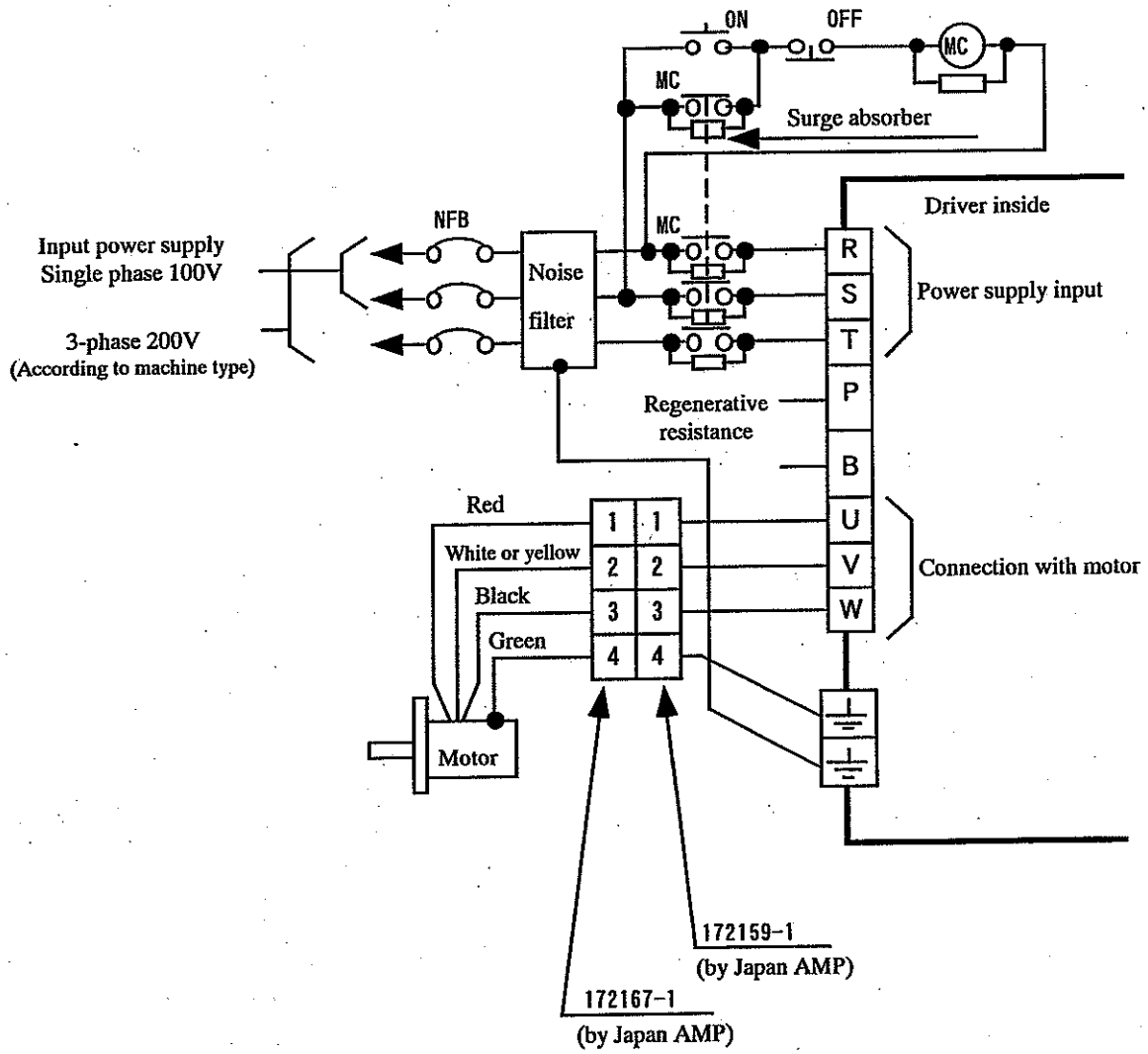

Fig. 6-1 Wiring to the terminal block

6-1-2 Wiring to connector I/F

- (1) For wiring, refer to Fig. 6-2 "Wiring example to connector I/F".
- (2) Supply DC 12-24V control signal power supply for external control connected between COM+ and COM- by the customer.
- (3) Install the position driver and the peripheral equipment within 3m in between to shorten the wiring.
- (4) Wire the power lines (R,S,T,U,V,W,⊕) by separating 30cm or more. Do not pass through the same duct and do not bind together, to prevent error operation.
- (5) Do not apply DC24 V, 50mA and above to each terminal of the control output (BUSY, ALM, COIN/DCLON P1OUT - P16OUT) and do not apply voltage in reverse polarity. It may break the position driver.
- (6) When a relay is directly driven at the control output terminal, fit diode in parallel with the relay in the direction shown in Fig. 6-2. If diode is not fit or fit reversely, the position driver will be broken.
- (7) Either positioning finish signal (COIN) or decelerating output signal (DCLON) can be selected and used by setting of parameter. For details, refer to section 10-2-4 "NC data" (Page 33).
- (8) Frame ground terminal (FG) is connected with the earth terminal (⊕) inside the driver.
- (9) Drive inhibit input signal (limit) is defined as CW drive inhibit input (CW limit) when rotating the servo motor to CW direction and as CCW drive inhibit input (CCW limit) when rotating to CCW direction. CW direction and CCW direction are defined here as the following:

* Rotating direction, seeing from the motor shaft side (arrow direction)

Machine movement may be reversed even with the motor rotation in the same direction, depending on the fitting position and method of the motor. Also, CW/CCW limit is set to operate normally when the input is ON for its safety. If the connection is opened by some errors, the input will be OFF and a limit will be applied. In case that limit function such as rotation is not necessary, set parameter No. 09 "Drive inhibit input inactive" as "1."

- For checking the connection of drive inhibit input signal, perform it under servo-off state with functions of console or I/O monitor of personal computers after completing the wiring. (For I/O monitor function of the console, refer to section 14-4-3 "I/O monitor" (Page 78)) For I/O monitor function used by softwares of personal computers, refer to the attached instruction manual for the softwares.

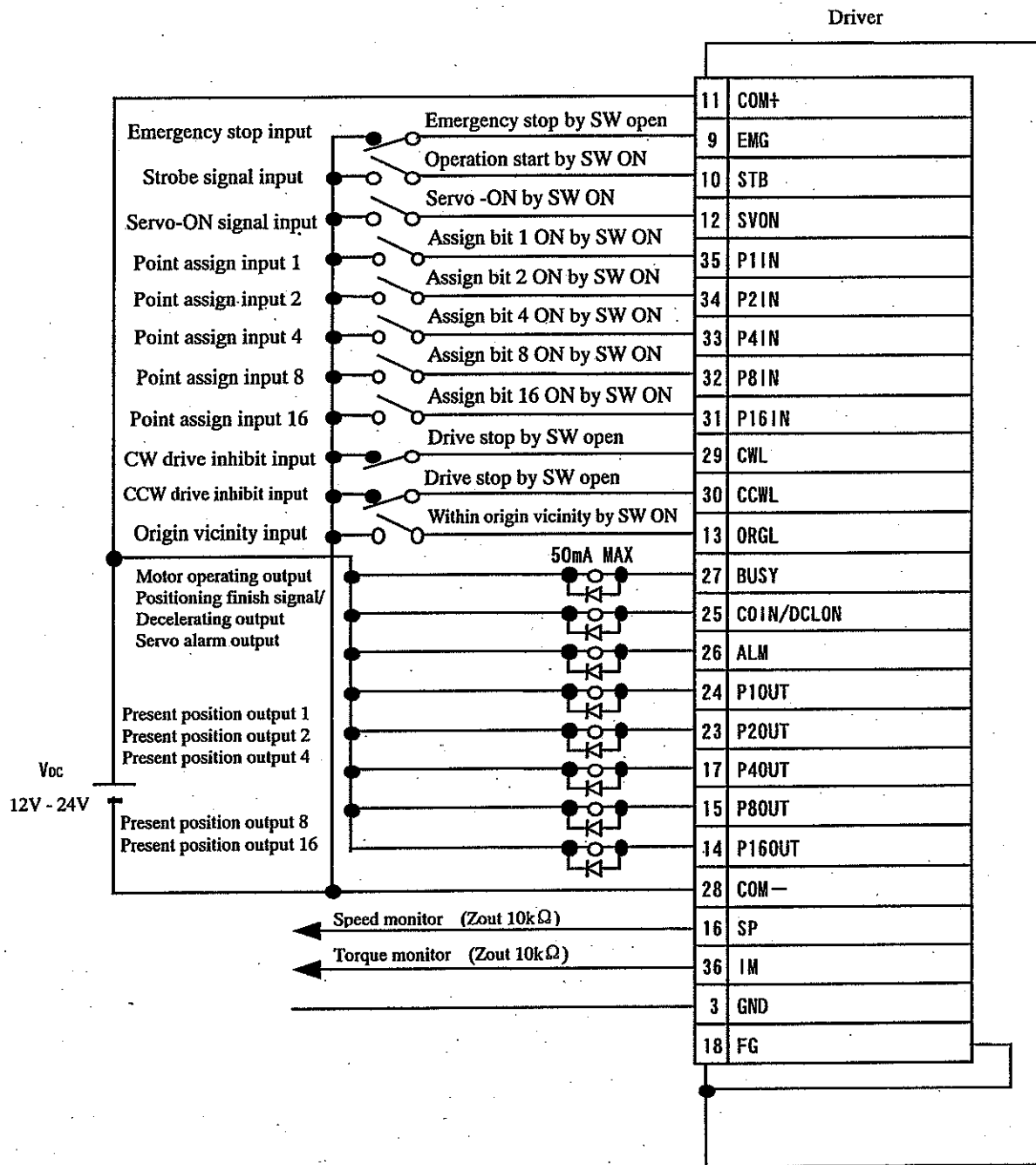

Fig. 6-2 Wiring example to connector I/F

Receptacle on position driver side		Applicable plug on user side (option)		Manufacturer
Connector mark	Product No.	Part name	Product No.	
Connector I/F	10236-52A2JL ^{Note1)}	Plug	10136-3000VE ^{Note2)}	Sumitomo 3M, Ltd.
		Shell kit	10336-52A0-008 ^{Note2)}	

Note 1) For receptacle, parts made by other manufacturers equivalent to products in above may be used.

Note 2) For plug shell kit, use the above products or other products equivalent to the above made by other manufacturers.

6-1-3 Wiring to Connector SIG

- (1) For the encoder cable, use a twisted pair wire having overall shield which is a stranded wire having the core of 0.18mm² or more.
- (2) The length of the cable must be within 20m. When the wiring is long, we recommend that double wiring be used in order to reduce the influence by the voltage drop for 5V (3,4 pin) and 0V (1,2 pin) of the power supply.
- (3) Be sure to connect the shield on the relay cable position driver side to 20 pin (FG) of the connector SIG. Connect the shield on the motor side of the relay cable to the shield of the shielding wire from the encoder.
- (4) Wire the power lines (R,S,T,U,V,W,⊕) by separating 30cm or more. Do not pass through the same duct and do not bind together, to prevent error operation.
- (5) When using a canon plug, connect the shield housing in the motor side of the encoder cable, to J-terminal.
- (6) Do not connect anything to the vacant terminal (5, 6, 13, 14, 15, 16, 19) of the connector SIG.
- (7) Frame ground terminal (FG) is connected with the earth terminal (⊕) inside the driver.

Receptacle on position driver side		Applicable plug on user side (option)		Manufacturer
Connector mark	Product No.	Part name	Product No.	
Connector SIG	10220-52A2JL ^{Note1)}	Plug	10120-3000VE ^{Note2)}	Sumitomo 3M, Ltd.
		Shell kit	10320-52A0-008 ^{Note2)}	

Note 1) For receptacle, parts made by other manufacturers equivalent to products in above may be used.

Note 2) For plug shell kit, use the above products or other products equivalent to the above made by other manufacturers.

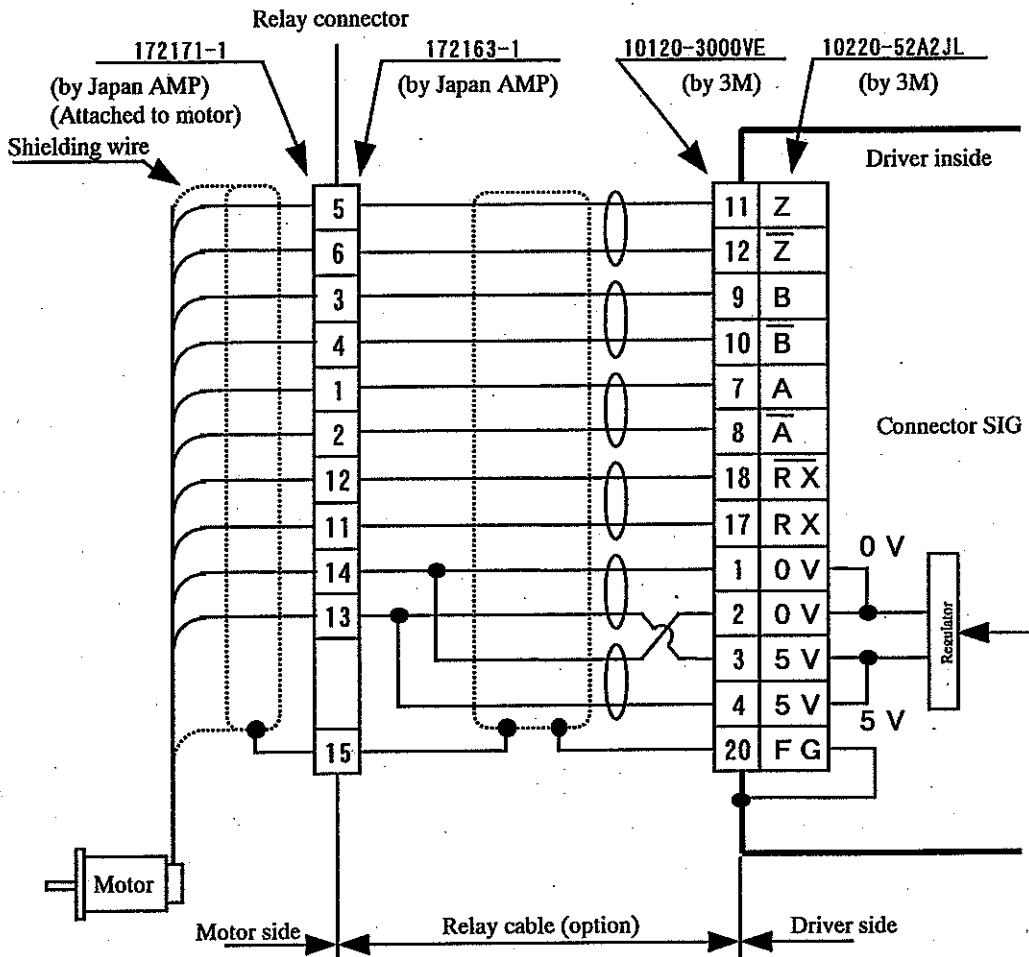

Fig. 6-3 Wiring example to connector SIG

6-1-4 Wiring to connector SER

(1) This position driver can be used, combining the console (option) or marketed personal computers specified in 11-1-1 Structure devices (Page 39) to the connector SER1.

- The following functions are available by combining with the console:
 - * NC parameter setting/change
 - * Gain setting/change
 - * Monitoring of control state
 - * Referring to alarm state
 - * Execution of origin return operation, jog operation and step operation
 - * Execution of reset command
 - * Automatic gain tuning
- The following functions are available by combining with marketed personal computers:
 - * NC parameter setting/change
 - * Various servo parameter setting/change
 - * Monitoring of control state
 - * Referring to alarm state
 - * Referring to alarm record
 - * Automatic gain tuning
 - * Waveform graphic function
 - * Parameter data save/load

Note) As connector SER2 cannot be used, do not connect a cable to the connector SER2.

(2) For connecting the personal computer and the position driver, use the special cable prepared as an option.

6-2 Wiring device selection

Applicable motor			Consumed power (in rated loading)	Overcurrent protection unit ^{Note 1)} (Breaker/Rated current)	Recommended noise filter ^{Note 2)}	Electromagnetic switch ^{Note 1)} (Contact point configuration)	Main circuit electric wire diameter (R·S·T·U·V·W·E)
Series name	Voltage	Output					
MSM	100V	- 50W	Approx. 0.3kVA	BBP2-10 (10A)	LF-210	BMF61041 (4a)	1.25mm ²
		100W	Approx. 0.4kVA	BBP2-15 (15A)	LF-215	BMF61041 (4a)	1.25mm ²
		200W	Approx. 0.5kVA	BBP2-15 (15A)	LF-215	BMF61041 (4a)	2mm ²
		400W	Approx. 1.0kVA	BBP2-30 (30A)	LF-230	BMF61041 (4a)	2mm ²
	200V	- 100W	Approx. 0.3kVA	BBP3-5 (5A)	LF-305	BMF61042 (4a)	1.25mm ²
		200W	Approx. 0.5kVA	BBP3-10 (10A)	LF-310	BMF61042 (4a)	1.25mm ²
		400W	Approx. 0.9kVA	BBP3-10 (10A)	LF-310	BMF61042 (4a)	1.25mm ²
		750W	Approx. 1.3kVA	BBP3-15 (15A)	LF-315	BMF61042 (4a)	2mm ²

Note1) Product No.s for overcurrent protection unit (Breaker) and electromagnetic switch are of Matsushita Electric Works, Ltd.

Note 2) Product No.s for noise filter are of Tokin Corporation.

7 Function

7-1 Details of input/output signals (Connector I/F)

Type	Application (Signal name)	Symbol	Connector Pin No.	Contents
Control Power Supply	Control signal power supply	COM +	11	<input type="checkbox"/> Connect the + pole of the control signal power supply (12-24V) to the COM+ (11pin) and the -pole to the COM- (28 pin). <input type="checkbox"/> Prepare the control signal power supply by customers. <input type="checkbox"/> Power supply capacity differs according to the control output circuit structure. Prepare the power supply with sufficient margin. (Power supply capacity: 500mA and above)
		COM -	28	
Input Signal	Emergency stop input	EMG	9	<input type="checkbox"/> Normally, connect to the COM- of the control signal power supply. <input type="checkbox"/> If setting the connection to the COM- with open-state, an emergency stop error will be made, and the position driver protection function will be operated. For resetting the emergency stop error, turn the power supply on again.
	Strobe signal input	STB	10	<input type="checkbox"/> Normally, set to the open-state. When connecting to the control signal power supply COM-, the position driver reads the signal of point assign input, starting its operation. <input type="checkbox"/> After 10ms. or more of setting the point assign input, connect the strobe signal input (STB signal) to the COM-. The position driver may not read the point assign input correctly. <input type="checkbox"/> Input STB signal for 10ms. or more. TO confirm that the STB signal is definitely received, return the STB signal to the open-state after receiving BUSY signal from the position driver. Refer to section 12-6 "Interface timing" (Page 48).
	Servo-ON signal input	SVON	12	<input type="checkbox"/> If connected to the COM- of the control signal power supply, the position driver becomes Servo- ON state. <input type="checkbox"/> If connection to the COM- is opened, the position driver becomes Servo-OFF state, cutting off the power supply to the motor, operating the dynamic brake and clearing the deviation counter. Note 1) When transferring from Servo-OFF to Servo-ON, be sure to check that the motor is stopped. Note 2) For preventing transient troubles, be sure to turn the power supply ON/OFF in Servo-OFF state. Note 3) After transferring to Servo-ON, take 120ms. or more for time before giving a command. Note 4) If set with Servo-OFF state, the position driver control state moves to reset the state. For performing step operation, execute the origin return command again. However, it is possible to keep the control state at Servo-ON with an option setting. For details and cautions, refer to section 12-8-3 "Control state selection at servo-off" (Page 57). Note 5) As the frequent repeat of Servo ON/OFF may damage the built-in dynamic brake circuit in the position driver, avoid operation in such way.
	Point assign input	P11N - P16IN	35·34·33·32·31	<input type="checkbox"/> Input the position driver command. For details of the command, refer to section 12. "Operation" (Page 40).

Type	Application (Signal name)	Symbol	Connector Pin No.	Contents
Input Signal	CW drive inhibit input	CWL	29	<input type="checkbox"/> In case of having linear drive etc., structure is made in the way to connect to the limit switch in the CW direction in viewing from the motor shaft end and to close the limit switch in the normal operation. <input type="checkbox"/> Under unfinished origin return state, if the CW limit switch is opened, exceeding the limit of the motor position, torque to the CW direction will not be generated. However, by setting an option, it is possible to allow torque output even with the limit switch opened and to inhibit only the pulse output. For details and cautions, refer to section 12-8-4 "Torque output selection at limit signal input" (Page 57). After finishing the origin return, if the switch is opened over the limit, hardware limit input error (55) will be generated. <input type="checkbox"/> When the limit switch is not used, always connect to the COM- of the control signal power supply. <input type="checkbox"/> Dynamic brake can be operated with this input. For details, refer to section 7-3 "Dynamic Brake" (Page 20).
	CCW drive inhibit input	CCWL	30	<input type="checkbox"/> Operation to the CCW direction is inhibited with this input. For functions and structure, refer to the above "CW drive inhibit input."
	Origin vicinity input	ORGL	13	<input type="checkbox"/> Within the origin vicinity, connect to close the origin vicinity input. Note) For origin vicinity input, wire to connect to the COM- at the position 180 degrees before the Z-phase.
Output Signal	Motor operation state output	BUSY	27	<input type="checkbox"/> The transistor will be turned off while the position driver is processing the operation command.
	Positioning finish output	COIN	25	<input type="checkbox"/> With this output signal, it is possible to select and use positioning finish output (COIN) and decelerating output (DCLON) with the parameter. (For setting contents, refer to section 10-2-4 "NC data " (Page 33).) <input type="checkbox"/> The transistor will be turned on when reserved pulse amount of the deviation counter is in the range set by the user parameter No. 22 "Positioning finish range."
	Decelerating output	DCLON	25	<input type="checkbox"/> With this output signal, it is possible to select and use positioning finish output (COIN) and decelerating output (DCLON) with the parameter. (For setting contents, refer to section 10-2-4 "NC data " (Page 33).) <input type="checkbox"/> During the motor deceleration, the transistor will be turned on.
	Servo alarm output	ALM	26	<input type="checkbox"/> The output transistor will be turned off by detecting the error and operating the protection function.
	Present position output	P1OUT - P16OUT	24·23·17·15·14	<input type="checkbox"/> Output present motor position (Point No.). <input type="checkbox"/> All transistors will be turned off when turning the power supply on, generating an alarm and executing the reset command. All transistors will be turned on when finishing the origin return command.
Analog Speed Output	Speed monitor signal	SP	16	<input type="checkbox"/> It outputs the voltage with polarity in proportion to the motor speed and the position deviation. For switching the motor speed and the position deviation, it is possible to set with parameter No. 08 "speed monitor gain selection" and parameter No. 3B "monitor signal selection." Refer to section 10-3 "Details of Servo Parameters (User parameters) " (Page 35). +: Rotation/deviation at CCW -: Rotation/deviation at CW <input type="checkbox"/> For the full scale value of the speed monitor signal, it is possible to set two kinds respectively with parameter No. 08 "speed monitor gain selection." Refer to section 10-3 "Details of Servo Parameters (User parameters) " (Page 35). Note) Output impedance of the speed monitor signal is 10k Ω . Pay attention to the input impedance for the measuring instrument and the circuit to be connected.
		GND	3	
	Torque monitor signal	IM	36	<input type="checkbox"/> It outputs the voltage with polarity in proportion to generated torque of the motor. +: Generates torque at CCW -: Generated torque at CW <input type="checkbox"/> The relationship between the torque monitor signal output voltage and the generated torque, Approx. 3V/100% torque Note) Output impedance of the torque monitor signal is 10k Ω . Pay attention to the input impedance for the measuring instrument and the circuit to be connected.
		GND	3	
	Frame ground		18	<input type="checkbox"/> It is connected to the earth terminal of the driver.

7-2 Input/output circuit configuration

7-2-1 Control input

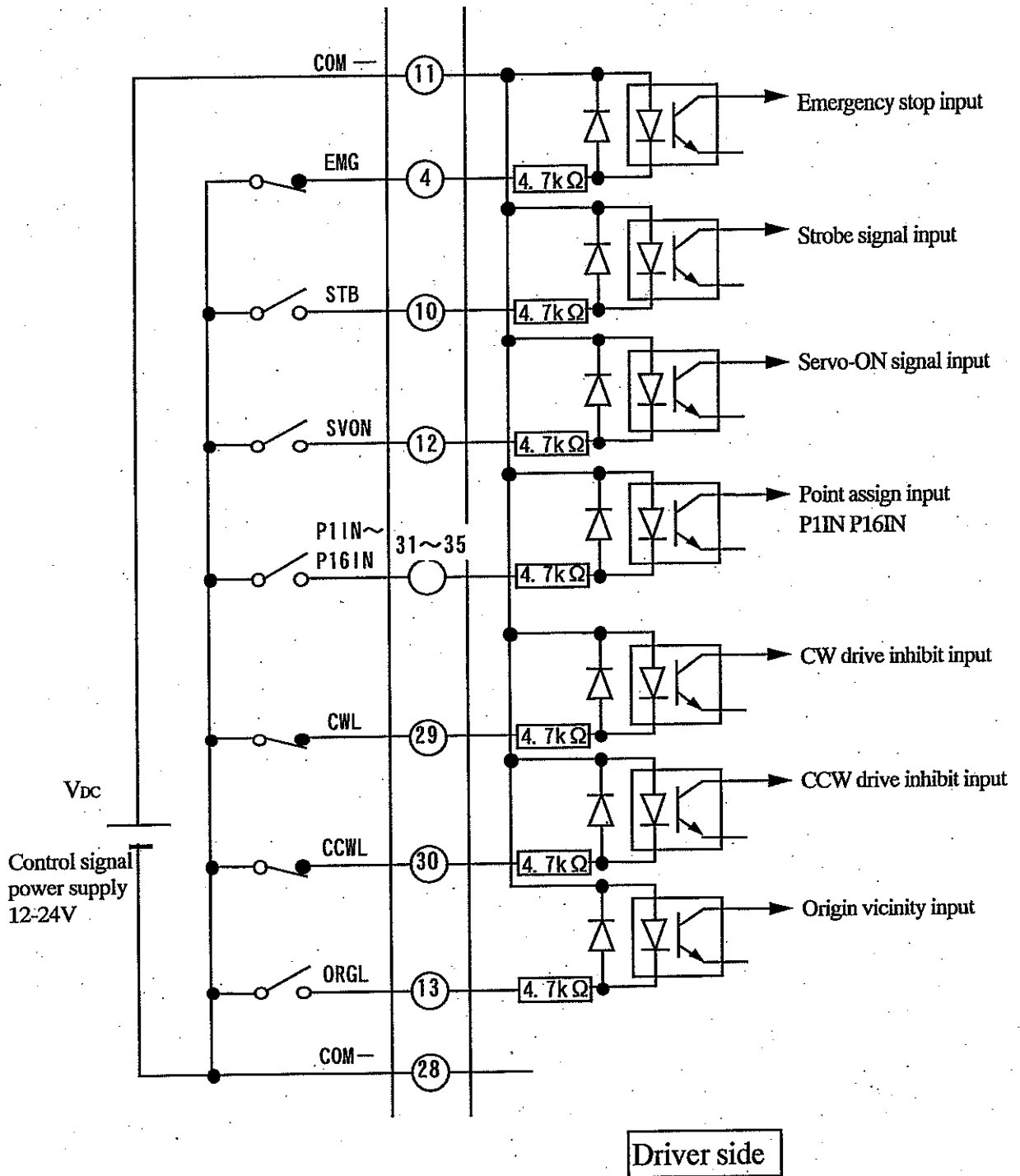

Connector I/F

Fig. 7-1 Control Input

7-2-2 Control output

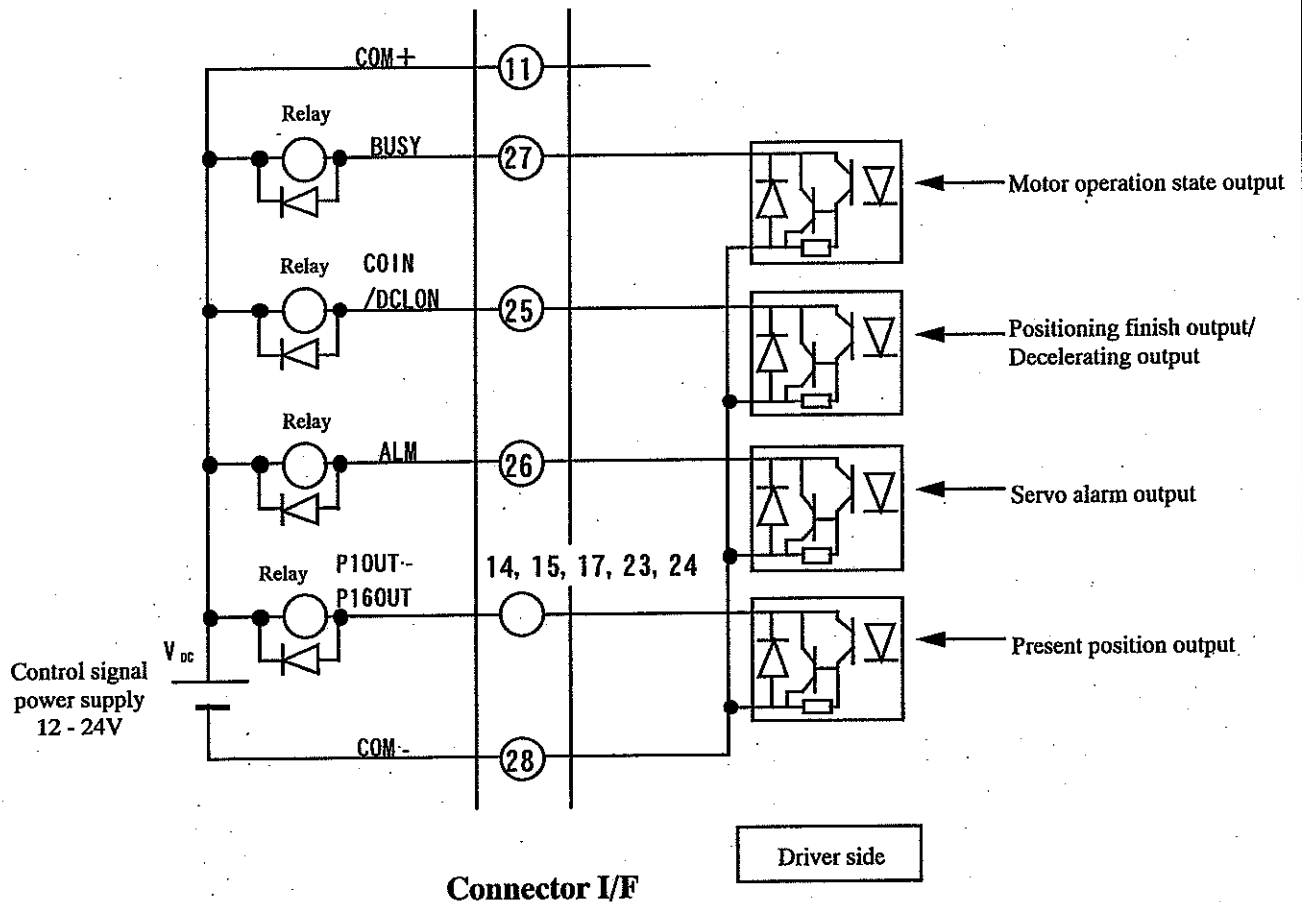

Fig. 7-2 Control output

- (1) Prepare the power supply (V_{DC}) for the control signal at your side. (DC12 - 24V, 0.5A or more)
- (2) Pay attention for the polarity of V_{DC} . Reversed polarity of the above figure 7-2 for the connection will damage the position driver.
- (3) In case of directly driving a relay with each output signal, install a diode in parallel to the relay as shown in Fig. 7-2. If you do not install a diode or install it in the reverse direction, the position driver will be damaged.
- (4) When each output signal is received by a logic circuit such as a gate, be sure to avoid influence by the noise.
- (5) The current fed to each output should be 50mA or less.

7-2-3 Analog signal output (Monitor output)

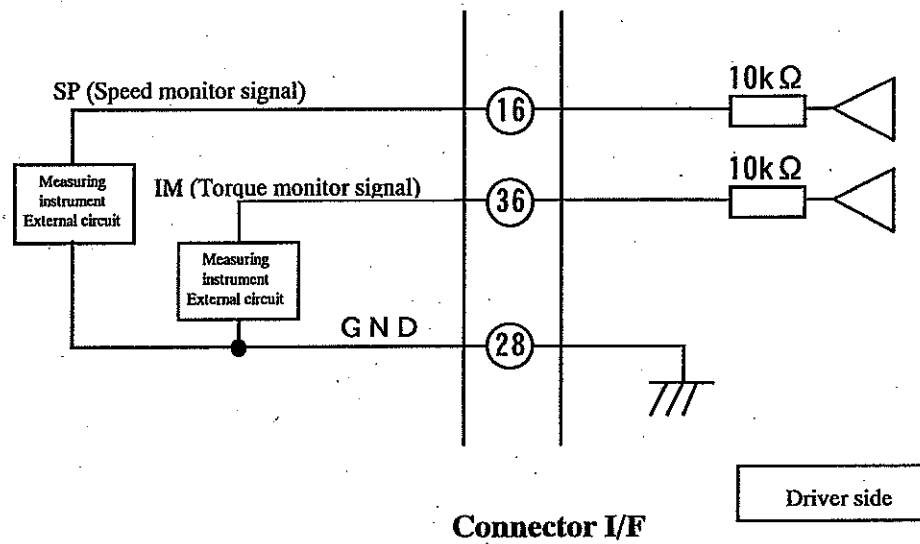

Fig. 7-5 Analog output

- (1) As shown in the above figure, SP output and IM output have $10\text{k}\Omega$ of the output impedance respectively. In case of connecting the measuring instrument or the external circuit to SP/IM output, connect a measuring instrument with high input impedance (Multi meter, oscilloscope, etc.) to reduce the tolerance.

7-3 Dynamic Brake

MSS*XP series has built-in dynamic brake for the emergency stop.

The dynamic brake will be operated in the following cases:

- (1) When the power supply is turned off.
- (2) When the servo is OFF.
- (3) When the protection function is operated.
- (4) During the deceleration operation under the case that the limit switch connected to CW drive inhibit input (CWL) of connector CN I/F is opened at the CW rotation.
- (5) During the deceleration operation under the case that limit switch connected to CCW drive inhibit input (CCWL) of connector CN I/F is opened at the CCW rotation.

Note1) In case of the above (2) (3) (4) (5), you can select whether the dynamic brake is operated or not with the setting of parameter No. 0A, 3D, and 3E. Refer to section 10-3 "Details of Servo Parameters (User parameters)" (Page 35).

Sequence at the drive inhibit input:	Parameter No. 0A
Sequence at the alarm:	Parameter No. 3D
Sequence at the Servo-Off:	Parameter No. 3E

Note2) The dynamic brake is provided with short-time rating, and is used only for the emergency stop.

Specifically, as the frequent repeat of Servo ON/OFF may damage the built-in dynamic brake circuit in the position driver, avoid operation in such way.

7-4 Automatic Gain Tuning

7-4-1 Summary

The driver sets the most appropriate gain automatically, by operating the motor with a certain pattern and by presuming the load inertia from the torque required at the time.

7-4-2 Applicability

- This function is available only when the following conditions are satisfied.
- Even if they are satisfied, there may be some cases that you cannot apply this function, depending on the load condition.
In such cases, set it manually.

	Applicable conditions
Load inertia	<input type="checkbox"/> It should not be greatly fluctuated, making it within 3 times or more and under 15 times of the motor rotor inertia.
Load	<input type="checkbox"/> Machine stiffness should be as high as possible, including coupling to the motor (No belt drive is applicable.). <input type="checkbox"/> Backlash of the gear should be as small as possible. <input type="checkbox"/> There should not be unbalanced load 1/4 or more of the rated torque. (Especially when used at the vertical shift shaft) <input type="checkbox"/> Viscous load torque should be 1/4 or less of the rated torque. <input type="checkbox"/> There should not be safety problem and machine damage to be expected, even when having an oscillation state. <input type="checkbox"/> There should not be a problem with two revolutions for CCW, and with two revolutions for CW in both forward and reverse directions.

7-4-3 Notices

- (1) During the automatic gain tuning, the motor output torque is allowed up to the maximum torque set by parameter No. 06.
- (2) Oscillation state is made depending on the loading state.
Take enough care for the safety. When having oscillation, immediately cut the power supply or make Servo-Off.
- (3) If abnormal situation occurred during the automatic gain tuning, immediately cut the power supply or make Servo-Off.
- (4) When the load inertia cannot be presumed even if the automatic gain tuning is executed, the gain value is the same value as that before tuning, having no change.
- (5) After finishing the automatic gain tuning, note that the position driver becomes "reset state." (For the position driver state, refer to section 12-3 "Position driver state transition" (Page 42).

7-4-4 Automatic Gain Tuning Operation

- (1) When you set the machine stiffness No. (Higher the setting No., stiffer the tuning you can get.) and execute, the automatic gain tuning operation will be started.
- (2) Have 2 revolutions to CCW and 2 revolutions to CW for 2 times. Take this process as one cycle, and repeat 5 cycles at the maximum.
- (3) Operation acceleration will be increased by double per one cycle from the 3rd cycle. Depending on the loading state, there may be some cases such that the automatic gain tuning will be completed before 5 cycles, or the operation acceleration will not be changed. These are not considered as malfunctions.

About the machine stiffness No.

- This No. represents the stiffness of the machine, and ranges from 1 to 9.
With a higher stiffness machine, you can obtain higher value and set higher gain.
- Normally you should start setting the No. changing it to larger gradually, and repeat the automatic gain tuning before you encounter oscillation, abnormal noise or vibration.

7-4-5 How to operate

- (1) Shift the load to an position where no problem is found even with 2 revolutions of the motor.
- (2) Inhibit the command.
- (3) Make "Servo-ON."
- (4) Start up the automatic gain tuning.
In case of starting the automatic gain tuning with PANATERM for MSS*XP, refer to the instruction manual provided with PANATERM.
In case of doing the automatic gain tuning on the front panel, refer to section 13-3-8 "Automatic gain tuning" (Page 72) and section 14-5-5-2 "Automatic gain tuning function" (Page 87) for the automatic gain tuning with a console.
- (5) Write into EEPROM if no problem is found.

Note) If "Alarm" is generated or "Servo-Off" is input during the automatic gain tuning operation, it will lead to an automatic gain tuning error.

7-5 Protection Function

7-5-1 Summary

(1) Protection function operation

MSS*XP has various protection functions. If these protection functions operated, the servo alarm output (ALM) is changed from ON to OFF and it will be in the trip state. (Protection function is operated and the motor is stopped.)

(2) State indication

When protection function is operated with MSS*XP, error code, currently generated on 7 segment LED of the front panel, will be indicated with flashing. When using a console, error code and error name will be displayed on the console display. By using the communication function (Section 11. "Communication Function" (Page 39)), you can check the error state on the monitor of your personal computer.

7-5-2 Details of protection function

- Some error factors can be reset by giving a reset command to restart the position driver (Note1).

For other factors which cannot be reset, the power supply must be turned on again.

Protection Function	Error No.	Contents	Solution
Overvoltage Protection	12	<input type="checkbox"/> Voltage in the converter section is increased by regenerative energy. With 200V machine type, voltage became approx. 400VDC or above, and with 100V machine type, it became approx. 200VDC or above.	<input type="checkbox"/> Make the deceleration time longer or decrease the load inertia. Note) This cannot be applied for cases using regenerative brake continuously.
Undervoltage protection	13	<input type="checkbox"/> Power supply voltage dropped because of instant stop or insufficient power supply capacity.	<input type="checkbox"/> Check if the power supply voltage is within the allowable range. Note) Pay attention to voltage drop or open phase of the power supply by the insufficient power supply capacity or rush current when turning the power supply on.
Overcurrent Protection	14	<input type="checkbox"/> Output current in the converter section increased abnormally.	<input type="checkbox"/> After cutting the power supply completely, check for short circuit of the motor connection cables U, V, W. <input type="checkbox"/> Check insulation resistance between the motor connection cables U, V, W and the motor earth E, and also check for the decrease of insulation against the motor if it exists. <input type="checkbox"/> When overcurrent protection is operated by turning the power supply on again after the check, immediately cut the power supply as there have been a trouble.
Overload Protection	16	<input type="checkbox"/> The position driver was used continuously with load over the rated current value.	<input type="checkbox"/> Check if the motor connection cables U, V, W are not disconnected. <input type="checkbox"/> Decrease the gain. <input type="checkbox"/> Make the acceleration/deceleration time longer or decrease the load. <input type="checkbox"/> Increase the capacity for the motor and the position driver.
Detector Error	17	<input type="checkbox"/> Hardware error of the power supply detector was detected.	<input type="checkbox"/> Turn the power supply off and turn it on again.
Excessive position deviation protection	24	<input type="checkbox"/> Position deviation pulse exceeds the allowable range set by the parameter No. 23 (Position error limit).	<input type="checkbox"/> Input operation command to check if the motor rotates. <input type="checkbox"/> Check the output torque with the torque monitor, and check if the output torque is not saturated. <input type="checkbox"/> Set the user parameter No. 06 "Torque limit" to the maximum value. Check the gain adjustment according to the adjusting method. <input type="checkbox"/> If there is no problem for the above points, make the acceleration/deceleration time longer and reduce the speed with lighter load.
Deviation Counter Overflow	29	<input type="checkbox"/> The position deviation pulse is $2^{27}=134217728$ or above.	<input type="checkbox"/> Check the same in the above.
Overspeed Protection	26	<input type="checkbox"/> Motor speed exceeded the overspeed level set by the system parameter.	<input type="checkbox"/> Check if the speed data contents are too large. <input type="checkbox"/> Check if overshoot when accelerating was generated because of the gain adjustment failure.
Drive Inhibit Input Protection	38	<input type="checkbox"/> It trips if both CW and CCW drive inhibit inputs are turned off, judging it as an error.	<input type="checkbox"/> Check if there are no errors for switches of CW and CCW drive inhibit inputs, the electric wire and the power supply. <input type="checkbox"/> Specifically, check for the delay of starting the control signal power supply (12-24VDC). <input type="checkbox"/> Set the user parameter No. 01 "Rise delay" time large. <input type="checkbox"/> Check the setting of the limit input logic.
Encoder Connection Error	21	<input type="checkbox"/> Trip is made if the encoder connection error was found after turning the power supply on. (Normal receiving is not conducted at all.)	<input type="checkbox"/> Check the connection between the position driver and the encoder, connection error and the connection state of the connector SIG. <input type="checkbox"/> Check the power supply voltage ($5V \pm 5\%$) on the encoder side. <input type="checkbox"/> To return, reset the power supply.
Encoder Communication Error	22	<input type="checkbox"/> Trip is made if the encoder connection error was found after turning the power supply on such as breaking of the wire, etc.	<input type="checkbox"/> Check the connection between the position driver and the encoder, connection error and the connection state of the connector SIG. <input type="checkbox"/> Check the power supply voltage ($5V \pm 5\%$) on the encoder side. <input type="checkbox"/> To return, reset the power supply.
EEPROM Error Protection	36	<input type="checkbox"/> Error will be generated by having an error such as data breakage when reading data from EEPROM at the power supply input.	<input type="checkbox"/> Reset all parameters, and write in EEPROM.
Origin Return Error	51	<input type="checkbox"/> Abnormal limit signal was input during the origin return operation or it is not servo-on.	<input type="checkbox"/> Check if there are no errors for switches of CW and CCW drive inhibit inputs, the electric wire and the power supply. <input type="checkbox"/> Check if the motor is servo-on. <input type="checkbox"/> Check the setting of the limit input logic.

Protection Function	Error No.	Contents	Solution
Speed, Acceleration Undefined Error	52	<input type="checkbox"/> Speed data or acceleration data of the command to be operated are not set.	<input type="checkbox"/> Check the setting of the speed data and the acceleration data.
Emergency Stop Input Error	53	<input type="checkbox"/> Trip is made if the emergency stop input is turned off, judging it as an error.	<input type="checkbox"/> Check if there are no errors for switches of the emergency stop input, the electric wire and the power supply. <input type="checkbox"/> Specifically, check for the delay of starting the control signal power supply (12-24VDC) compared to that of the position driver. <input type="checkbox"/> Check the setting of logic of the emergency stop input. <input type="checkbox"/> To return, input the reset command or reset the power supply. (Select with parameter: Note 5)
Step Data Undefined Error	54	<input type="checkbox"/> Step data of the step command to be operated is not set.	<input type="checkbox"/> Check the setting of the step data.
Hardware Limit Input Error	55	<input type="checkbox"/> Trip is made when the motor operation direction limit is inputted after finishing the origin return and the present position cannot be held.	<input type="checkbox"/> Check if CW, CCW drive inhibit input is wired reversely. <input type="checkbox"/> Check if there are no errors for switches of CW and CCW drive inhibit inputs, the electric wire and the power supply. <input type="checkbox"/> Check the setting of the limit input logic.
Software Limit Error	56	<input type="checkbox"/> Trip is made if the motor position exceeds the software limit setting range after finishing the origin return.	<input type="checkbox"/> Check the step data and the operation sequence. <input type="checkbox"/> Check the software limit range.
Present Position Overflow Error	57	<input type="checkbox"/> Trip is made if the motor position exceeds the range of -1073741824 - 1073741823 after finishing the origin return. (Note 6)	<input type="checkbox"/> Check the step data and the operation sequence.
System Error Protection	98	<input type="checkbox"/> Trip is made if the self-diagnostic function of inner system judges that there may be a possibility of some error.	<input type="checkbox"/> Turn the power supply off once, and turn it on again. If trip is still made with indication shown in the left, there may have been a trouble. Immediately cut the power supply.
CPU Error Protection	30		
Other Error Protection	99		

Note1) To return from the trip state, it is possible by turning the power supply off, removing the cause, and then turning it on again, or by inputting the reset command. (Position driver control state will be shifted to the reset state. Refer to section 12-3 "Position driver state transition" (Page 42). However, when protection functions indicated below are operated, it cannot be cleared by the reset command.

- Encoder connection error • Encoder communication error • Emergency stop input error (Note 5)
- System error protection • CPU error protection • Other error protection

In these cases, reset by turning the power supply on again.

Note 2) In case that EEPROM parameter error protection is operated, turn the power supply on again, check on all parameters and reset.

Note 3) Overload protection can be returned by executing the reset command 10 seconds after the alarm generated.

Note 4) If the parameter is changed during generating the undervoltage protection, note that the parameter becomes inactive after cutting the power supply as the parameter is not stored in EEPROM, requiring notice.

Note 5) If emergency stop error (53) is generated, it can be returned only by resetting the power supply under the initial setting state. To return with the reset command, it is necessary to change NC parameter. (Refer to section 10-2-4 "NC data" (Page 33).)

Note 6) By setting the option function for NC parameter, it is possible to make the Present position overflow error (57) inactive. (Refer to section 10-2-4 "NC data" (Page 33).)
In case of making the Present position overflow error inactive, absolute position transfer cannot be used with the step command.

8 Operation

8-1 Inspection before operation

- (1) Is wiring made correctly?
Are there any error connections and caulking loosening for terminals R,S,T of the power supply input and terminals U, V, W, ⊕ of the motor output?
- (2) Is the input power supply correct as the rating?
- (3) Are there any positions with short-circuit due to the electric wire chips, etc.?
- (4) Are screws and terminals not loosened? Are connectors inserted securely?
- (5) Are motor connection cables not short-circuited or grounded?

8-2 Trial operation

- (1) Perform the following operations for the safety.
 - Set the motor under unloaded condition (Nothing is connected to the shaft.).
 - If rapid accelerating/decelerating operation is performed, it is dangerous that the motor moves because of the reaction. Be sure to fix it.
- (2) In case of using a motor with a brake, be sure to release the brake.
- (3) Set the polarity of signals connected to the connector I/F input signal pins and switches as shown in Fig. 8-1, and apply control signal power supply (DC12 - 24V).
- (4) Turn the power supply on for the position driver.
LED on the front panel displays any of the following according to the setting value for parameter No. 01 "LED initial state."

P 0	• • • •	Position deviation	
r 0	• • • •	Motor speed	
Γ 0	• • • •	Torque output	
Id 1	• • • •	ID No.	For parameters, refer to section 10-3 "Details of Servo Parameters (User parameters)" (Page 35), and section 13-3-1 "Monitor mode" (Page 60) for details of display contents.
P-----	• • • •	Present position	
In 0-A	• • • •	Input/output signal	
Err.--	• • • •	Error No.	
U- 1.00	• • • •	Parameter used by manufacturer	

At the time, if there is an error in the position driver, the error code will be displayed, flashing LED.

Err53

In this case, provide suitable correction after cutting the power supply, and then turn the power supply on again.

- (5) Input servo-on signal. It will become motor drive available state.
- (6) For the motor operation, refer to section 12-2 "Initial setting of NC parameter" (Page 41) to set NC parameters and drive the motor.
- (7) Try parameter change and gain adjustment.

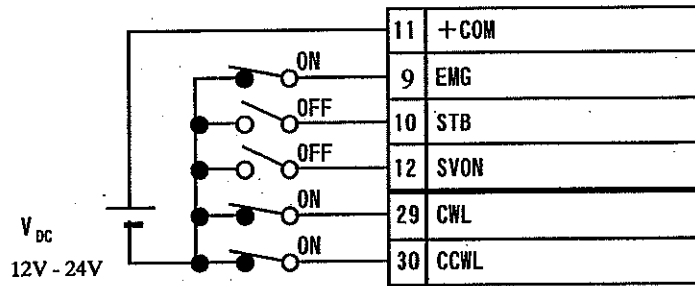

Fig. 8-1 Connector I/F connection example

9 Adjustment

9-1 Confirmation of rotary encoder voltage

- ◆ This driver has built-in power supply for rotary encoder. To operate the rotary encoder normally, the power supply voltage needs to be in the range of $5V \pm 5\%$. If the cable for the rotary encoder connection is too long, it may not be in the above range because of the voltage drop. Take measurement of the rotary encoder voltage near the motor (Between 13 pin (+5V) and 14 pin (0V) of relay connector for the encoder, or between H terminal (+5V) and G terminal (0V) of canon plug / Fig. 6-3 Wiring example to connector SIG - Page 13) and confirm if it is in the range of 4.75V - 5.25V. If it is under 4.75V, see section 6-1-3 "Wiring to Connector SIG" (Page 12) and make double wiring for the rotary encoder.

9-2 Gain adjustment

Although MSS*XP Series has automatic gain tuning function. However, readjustment may be necessary in case that adjustment cannot be done finely even with this function due to restrictions such as loading conditions, etc., unfavorable phenomena such as vibration and noise generated when stopping and operating, or optimum response and stability are desired to meet the load respectively. In these cases, readjust according to section 9-2-1 "Gain adjustment principle" (Page 29).

- MSS*XP Series is of digital AC servo structure. However, for the adjustment method of servo gain, it is designed to be able to use experience on the adjustment of the conventional analog servo driver. Fig. 9-1 shows an image of equivalently-converting the MSS*XP Series servo control section to the conventional analog servo method.

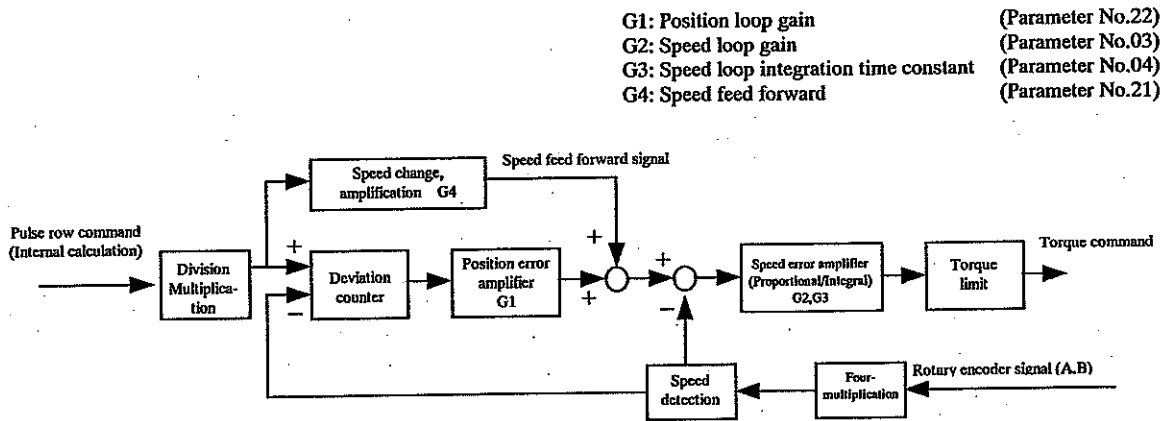

*One rotation with 10000-pulse input.

Fig. 9-1 Equivalence block diagram

9-2-1 Gain adjustment principle

- (1) Set speed feed forward to the minimum value (0%) with the user parameter No. 21, referring to section 10-1-2 "Servo parameters" (Page 31) and section 11 "Communication Function" (Page 39).
- (2) Then, set speed loop gain within the range of not causing oscillation as much as possible with the user parameter No. 03.
- (3) Then, set position loop gain within the range of not causing oscillation as much as possible with the user parameter No. 20.
- (4) Then, set speed loop integration time constant as small as possible with the user parameter No. 04 as needed. With smaller value, speed to make deviation when positioning to 0 will be faster.
- (5) Finally, only in case that extremely faster response speed is desired, gradually increase speed feed forward gain with the user parameter No. 21. However, if it is too large, speed overshoot will be increased.

Setting example of gain) In case of having relatively high stiffness such as for ball screw,

Position loop gain:	100-200
Speed loop gain:	150-300
Speed integration time constant:	20-50

9-2-2 Notices in gain adjustment

- (1) Optimum value for gain setting is widely varied according to the load. When the loading condition is changed greatly, readjustment is necessary.
- (2) When using speed loop integration time constant at the maximum value (1000ms.), it may not enter in the positioning finish range set by the user parameter No. 22 and positioning finish signal (COIN) may not be output. Normally, it should be "100ms." or under.
- (3) If the setting is raised excessively during the gain adjustment, oscillation state may occur. At the time, immediately lower the gain setting to stop the oscillation. If the oscillation does not stop in any way, turn the power supply off once to turn the servo-on command off, turn the power supply on again, lower the gain setting and resume from the beginning.

10 Parameter

10-1 Summary of parameter

MSS*XP Series has the servo parameters for adjusting and setting properties and functions, and NC parameters for storing position information for positioning, speed information and acceleration/deceleration time.

When performing the setting change and the contents check of these parameters, use a console (option) or marketed personal computers. For the console, the parameters which can be set are partly restricted.

10-1-1 NC parameter

- (1) There are four kinds of NC parameters in the following:
 - ① Step data storing positioning information for step operation
 - ② Speed data storing step operation speed, jog speed and origin return speed
 - ③ Offset data storing origin offset and software limit
 - ④ NC data storing other acceleration/deceleration time, operation direction, etc.
- (2) For details of NC parameters, refer to section 10-2 "Details of NC Parameters" (Page 32). For initial setting method of NC parameters, refer to section 12-2 "Initial setting of NC parameter" (page 41).
- (3) In case of setting each parameter with PANATERM for MSS*XP, refer to the attached instruction manual for PANATERM.
When setting each parameter with a console, refer to section 14 "Console operation" (Page 74).

10-1-2 Servo parameters

(1) There are two kinds of servo parameters in the following:

- ① User parameters set and changed by users.
 - ② System parameters which can be referred to but cannot be set and changed by users.
- Among servo parameters, part of parameters such as gain can be set by a console. However, to set all parameters, PANATERM for MSS*XP must be used with the front panel or marketed personal computers.

(2) A list of servo parameters is shown below. For details of individual parameters, refer to section 10-3 "Details of Servo Parameters (User parameters) " (Page 35).

Type	Parameters No.	Parameters name	Range	Standard delivery setting	Console edit
User Parameters	00	Name of axis	0 - 31	0	
	01	LED initial display	0 - 7	1	
	03	Speed loop gain	25 - 3500	100	⊙
	04	Speed loop integration time constant	1 - 1000	50	⊙
	05	Speed detection filter	0 - 4	4	⊙
	06	Torque limit setting	0 - 400	*	
	08	Speed monitor gain (selection)	0 - 1	0	
	09	Inactive drive inhibit input	0 - 1	0	
	0A	Sequence at drive inhibit input	0 - 1	0	
	10	Startup delay time	0 - 600	0	⊙
	20	Position loop gain	0 - 1000	*	⊙
	21	Speed feed forward	0 - 100	0	⊙
	22	Positioning finish range	0 - 32766	10	⊙
	23	Position error limit	1 - 32766	30000	
	24	Cancel of position error limit	0 - 1	0	
	2A	Torque filter time constant	0 - 2500	0	⊙
	2B	Feed forward filter time constant	0 - 6400	0	⊙
	30	2nd speed loop gain	25 - 3500	0	
	31	2nd speed loop integration time constant	1 - 1000	0	
	32	2nd position loop gain	10 - 1000	0	
	33	2nd gain operation setting	0 - 1	0	
	34	2nd gain switching delay time	0 - 10000	0	
	3B	Speed monitor signal selection	0 - 1	0	
	3D	Sequence at alarm	0 - 3	0	
	3E	Sequence at servo-off	0 - 7	0	
System Parameters	00	Motor poles	<input type="checkbox"/> This parameter is determined by the manufacturer depending on the specifications of applied motor, mode type of the position driver, etc. <input type="checkbox"/> Setting values for these parameters cannot be changed.		
	01	Encoder pulse number			
	02	J/T ratio			
	05	Over speed level			
	06	Max. torque setting			
	07	Overload time constant			
	08	Overload level			

Note 1) "Standard delivery setting" may be different from the values shown in the above depending on the applied motor.

Note 2) Delivery setting of parameters with * mark is different for each machine type.

Note 3) Note that some parts such as parameter No., setting range, and setting contents are different from those of the conventional type "MSS*EP" series.

10-2 Details of NC Parameters

10-2-1 Step data

Positioning data when executing step command is defined. Refer to the following table for point No. 1 - 28 and setting contents.

When the positioning is conducted with undefined step data, step data undefined error (54) will be generated.

Item	Setting range	Contents
Position data	-1073741824 - 1073741823 (pulse)	<input type="checkbox"/> Coordinate data for positioning is inputted.
Speed selection No.	1 - 10	<input type="checkbox"/> Speed selection No. for positioning speed is set by speed data.
Positioning mode	ABS/INC	<input type="checkbox"/> Positioning method is designated. Designation of ABS (Absolute position) and INC (Relative position)

Note) The positioning mode will be inactive when using it with NC parameter option setting of "only using relative transfer." (It will always be a relative position command.)

10-2-2 Speed data

When each corresponding command is executed under undefined state for the speed data, Speed/acceleration undefined error (52) will be generated.

Item	Setting range	Contents
Origin return speed	5 - 500 (kpps)	<input type="checkbox"/> Motor speed when origin-returning is determined. Speed detecting Z-phase is fixed to 5 kpps.
Step speed 1-10		<input type="checkbox"/> Motor operation speed designated by the speed selection No. in the step data is determined. <input type="checkbox"/> It is possible to memorize 10 speeds.
Jog speed (low speed)		<input type="checkbox"/> Speed of jog low-speed operation is determined.
Jog speed (high speed)		<input type="checkbox"/> Speed of jog high-speed operation is determined.

10-2-3 Offset data

Item	Setting range	Contents
Origin offset	- 1073741824 - 1073741823 (pulse)	<input type="checkbox"/> Origin offset is inputted by transfer amount from the machine origin position. For details, refer to section 12-8-1 "Origin return offset function" (Page 56). <input type="checkbox"/> When finishing the origin return, to move the motor automatically from the machine origin position to the origin offset position, it is set with option setting for NC parameter "Operation selection at origin return finish." For the motor operation, refer to section 12-8-1 "Origin return offset function" (Page 56) and for setting method, refer to section 10-2-4 "NC data" (Page 33). <input type="checkbox"/> This parameter will be active after resetting the power supply.
+direction software limit	0 - 1073741823 (pulse)	<input type="checkbox"/> Max. transfer amount of + and - directions are set. <input type="checkbox"/> When finishing the origin return, if it exceeds the software limit at the motor operation, Software limit error (56) will be generated. <input type="checkbox"/> When the software limit value is 0, software limit for the direction becomes inactive.
-direction software limit	-1073741824 - 0 (pulse)	

10-2-4 NC data

Item	Setting range	Contents
Step operation acceleration time	10 - 10000 (ms)	<input type="checkbox"/> Acceleration/deceleration time for the step operation is set. <input type="checkbox"/> Arrival time up to 500kpps is set. <input type="checkbox"/> When performing step operation without setting this parameter, Speed/overspeed undefined error (52) will be generated.
Jog operation acceleration time	10 - 10000 (ms)	<input type="checkbox"/> Acceleration/deceleration time for the jog operation is set. For functions and setting methods, comply with "Step operation acceleration time" described in the above.
Origin return acceleration time	10 - 10000 (ms)	<input type="checkbox"/> Acceleration/deceleration time for the origin return operation is set. For functions and setting methods, comply with "Step operation acceleration time" described in the above.
Jog operation direction	0 - 1	<input type="checkbox"/> Jog operation direction is set. For details, refer to section 12-2 "Initial setting of NC parameter" (Page 41).
Origin return direction	0 - 1	<input type="checkbox"/> Origin return operation direction is set. For details, refer to section 12-2 "Initial setting of NC parameter" (Page 41).
Pulse output direction setting	0 - 1	<input type="checkbox"/> MSS*XP coordinate system direction is set. For details, refer to section 12-2 "Initial setting of NC parameter" (Page 41)
Teaching transfer amount setting	0 - 32767	<input type="checkbox"/> When teaching position data using the front panel or a console, pulse number which will be transferred by pressing the jog key for a moment will be set.
S-form acceleration/deceleration setting	0 - 10	<input type="checkbox"/> S-form acceleration/deceleration is set. When 0 or 10 is set, it will move with linear acceleration/deceleration. For S-form acceleration/deceleration, refer to section 12-7 "S-Form acceleration/deceleration function" (page 55).
Input logic setting	0 - 8063	<input type="checkbox"/> Input signal logic can be inverted. Refer to Fig. 10-1 "Input logic setting".
Option setting	0 - 123	<input type="checkbox"/> Special functions for the position driver are set. Contents to be set is as follows: <ol style="list-style-type: none"> ① Selection of position finish output (COIN) and decelerating output (DCLON) ② Operation selection after the origin return finish ③ Resetting method selection when emergency stop error (53) is generated. (Power supply reset, reset command) ④ Positioning method selection (Selection of active or inactive for present position overflow error) ⑤ Control state selection at servo-off input ⑥ Torque output selection at limit signal input <input type="checkbox"/> For setting method, refer to Fig. 10-2 Option setting. <input type="checkbox"/> For details of ②, refer to section 12-8-1 "Origin return offset function" (Page 56). <input type="checkbox"/> For details of ④, refer to section 12-8-2 "Positioning method selection" (page 56). <input type="checkbox"/> For details of ⑤, refer to section 12-8-3 "Control state selection at servo-off" (Page 57). <input type="checkbox"/> For details of ⑥, refer to section 12-8-4 "Torque output selection at limit signal input" (Page 57). <input type="checkbox"/> This parameter becomes active after resetting the power supply.

(1) Input logic setting

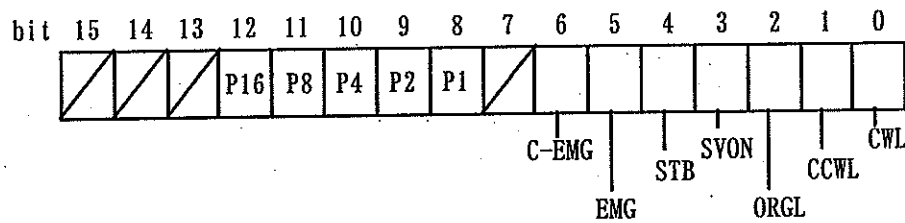

Note1) C-EMG: Console emergency stop switch

Note2) For input logic setting, contents in the above figure are set in decimal number.

Setting example 1) For inverting only EMG logic, set $2^5 = 32$

Setting example 2) For inverting EMG and CWL, or CCWL logic, set $2^5 + 2^1 + 2^0 = 32 + 2 + 1 = 35$

Fig. 10-1 Input logic setting

(2) Option setting

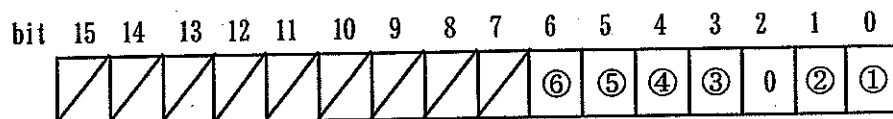

① Output signal selection

- 0: Decelerating output (DCLON) is used.
- 1: Positioning finish signal (COIN) is used.

② Operation selection after the origin return finish

- 0: Stop at the machine origin position.
- 1: Automatically move to the offset position.

③ Reset method selection at the emergency stop

- 0: Return with the power supply reset
- 1: Return with the power supply reset or reset command

④ Positioning method selection

- 0: Absolute transfer and relative transfer are used. (Present position overflow error active)
- 1: Only relative transfer is used. (Present position overflow error inactive)

⑤ Control state selection at the servo-off

- 0: Normally reset state at the servo-off.
- 1: Hold the present state at the servo-off.

⑥ Torque output selection at the limit input

- 0: Inhibit torque output in the limit input direction.
- 1: Allow inhibit torque output in the limit input direction, and only inhibit pulse output

Note1) For setting input logic, set the contents in the above figure in decimal number.

Note2) This parameter becomes active after resetting the power supply.

Setting example) For use of COIN, return with reset command for emergency stop error and torque output at the limit input,

$$2^6 + 2^3 + 2^0 = 64 + 8 + 1 = 73 \text{ and set } 73$$

Fig. 10-2 Option setting

10-3 Details of Servo Parameters (User parameters)

No.	Parameter	Setting range	Function · Contents
00	Name of Axis	0 - 31	<input type="checkbox"/> In case of using multiple axis, when referring to or setting of parameter and monitoring the control condition by a personal computer, it is used to identify to which axis the personal computer does access. Also, it is used for ID indication on the front panel. <input type="checkbox"/> When this parameter is "0," setting of rotary switch on the front panel becomes active. <input type="checkbox"/> Setting value of this parameter does not affect any servo operation.
01	LED Initial Display	0 - 7	<input type="checkbox"/> On the initial state when turning on the power supply, etc., select from the following methods for data to be displayed at 7 segment LED. 0: Displays the reserved pulse amount of position deviation counter. 1: Displays the motor speed with polarity. 2: Displays the motor torque with polarity. 3: Displays the driver ID No. 4: Displays the present position. 5: Displays the I/O state. 6: Displays the latest error contents. 7: Displays the parameter used by the manufacturer. <input type="checkbox"/> For details of contents to be displayed, refer to section 13-3-1 "Monitor mode" (Page 60) Note1) If the polarity to display value data is +, + sign will not be displayed. Note2) If an error is generated when turning the power supply on, the generated error contents will be displayed with flashing regardless of this parameter.
03	Speed Loop Gain	25 - 3500	<input type="checkbox"/> It is proportional gain of the speed loop. By making this setting value larger, the gain will be increased. <input type="checkbox"/> Optimum value for speed loop gain differs depending on the load inertia and the type of the motor.
04	Speed Loop Integration Time Constant	1 - 1000	<input type="checkbox"/> It is integration time constant of the speed amplifier. By making this setting value smaller, this will be integrated faster. Note) If integration time constant is set to the maximum value (1000) of the setting range, integration time constant will be infinite (No integration).
05	Speed Detection Filter	0 - 4	<input type="checkbox"/> Select the kind (Time constant) of digital filter for the speed detection signal.
06	Torque Limit Setting	0 - 400	<input type="checkbox"/> On the normal specifications of position driver, approx. three times of the rated torque is allowed as the maximum torque if it is for a moment. If there is a possibility that this 3 times torque mode generates a problem for intensity of the motor load (machine), the maximum torque can be limited with setting of this parameter. <input type="checkbox"/> For setting value, provide % value against the rated torque (100%). Ex.) If setting value is 200, 200% (2 times) allowable output of the rated torque Note) This parameter cannot be set with value which exceeds the setting value with system parameter No. 06 (Maximum output torque setting) at the time of delivery. If set with value which exceeds the maximum output torque setting value, it will be automatically corrected to the setting value of the maximum output torque.

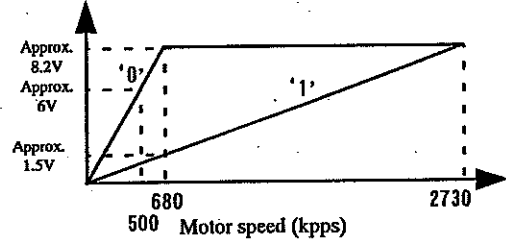
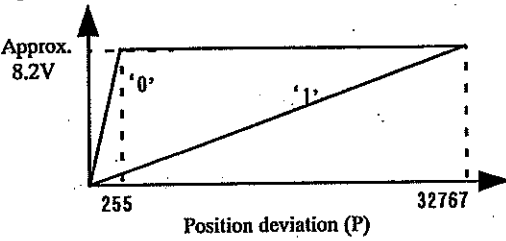
No.	Parameter	Setting range	Function * Contents									
08	Speed Monitor Gain (Selection)	0 - 1	<p><input type="checkbox"/> Select a full scale value of signal to be outputted to speed monitor signal (CN I/F 16 pin).</p> <table border="1" data-bbox="722 338 1402 439"> <thead> <tr> <th>Value</th> <th>Motor speed</th> <th>Position deviation</th> </tr> </thead> <tbody> <tr> <td>0</td> <td>Approx. 680 (kpps)</td> <td>255 (p)</td> </tr> <tr> <td>1</td> <td>Approx. 2730 (kpps)</td> <td>32767 (p)</td> </tr> </tbody> </table> <p><input type="checkbox"/> The following figure shows the relationship between motor speed/position deviation and monitor voltage.</p> <p>Speed monitor voltage</p>  <p>Speed monitor voltage</p>  <p><input type="checkbox"/> For each monitor signal, select with parameter No. 3B.</p>	Value	Motor speed	Position deviation	0	Approx. 680 (kpps)	255 (p)	1	Approx. 2730 (kpps)	32767 (p)
Value	Motor speed	Position deviation										
0	Approx. 680 (kpps)	255 (p)										
1	Approx. 2730 (kpps)	32767 (p)										
09	Inactive Drive Inhibit Input	0 - 1	<p><input type="checkbox"/> By setting this parameter as "1," CW drive inhibit input (CWL)/CCW drive inhibit input (CCWL) will be ignored and operated, judging it not in the drive inhibit state.</p> <p>Note) If this parameter is set with "0" and CW drive inhibit input (CWL) is opened, the motor will not be operated in the direction. When finishing the origin return, torque in the operation direction will not be generated, having Hardware limit input error (55) at the origin return finish. It is same when CCW drive inhibit input (CCWL) is opened. Also, both CWL and CCWL are opened, the motor will be stopped by activating the protection function of the position driver by drive inhibit input error.</p>									
0A	Sequence at Drive Inhibit Input	0 - 1	<p><input type="checkbox"/> When decreasing speed in case of operating CW drive inhibit input (CWL) or CCW drive inhibit input (CCWL), select with this parameter as follows whether dynamic brake should be operated or not.</p> <p>"0": Stop by activating the dynamic brake.</p> <p>"1": Free run stop without activating the dynamic brake.</p>									
10	Startup Delay Time	0 - 600	<p><input type="checkbox"/> Set the time until the startup of the position driver.</p> <p><input type="checkbox"/> In case that startup of external 24V power supply is slower than that of the position driver, it will be set to delay the startup time for the position driver.</p> <p style="text-align: right;">Unit: (100ms.)</p>									

No.	Parameter	Setting range	Function Contents
20	Position Loop Gain	0 - 1000	<input type="checkbox"/> Set position gain. Unit of the setting value is (1/S). <input type="checkbox"/> By making the setting value larger, the position gain and the servo stiffness (Typical hardness at servo locking) will be increased. Note) Note that too large setting may cause an oscillation.
21	Speed Feed Forward	0 - 100	<input type="checkbox"/> If high speed response is especially necessary, speed feed forward function can be added with position driver. <input type="checkbox"/> With this parameter, set the feed forward volume in the rate (%) against the command volume. Note) If the speed feed forward volume is set excessively, unstable situation will be increased and oscillation will be generated. We recommend you to set this parameter to "0" unless you need especially high speed response. If this parameter is set other than "0," set parameter 2B "Feed forward filter time constant" with 200 or more.
22	Positioning End Range	0 - 32766	<input type="checkbox"/> Set the detection level when judging the positioning end with the number of pulse. <input type="checkbox"/> When the number of reserved pulse for the deviation counter is within ± (setting value), judge that the positioning is completed and output (Output transistor is on.) the positioning end signal (COIN). Note) After feed back pulse of the rotary encoder is increased by 4 times, it is inputted to the deviation counter and the positioning end range is converted into the motor rotation angle as follows: $\text{Setting value} = \frac{\text{Positioning end range}}{4 \times \text{Pulse number of rotary encoder}}$
23	Position Error Limit	1 - 32766	<input type="checkbox"/> Set the detection level when judging the position deviation excessively with the number of the reserved pulse in the deviation counter. <input type="checkbox"/> Calculate the setting value with the following formula. $\text{Setting value} = \frac{\text{Judging level of position error (pulse)}}{16}$ <input type="checkbox"/> When the number of reserved pulse for the deviation counter exceeds the judgment level indicated with the above setting value, the motor will be stopped by activating the protection function of the position driver, judging it as error condition.
24	Cancel of Position Error Limit	0 - 1	<input type="checkbox"/> With this parameter, the protective function of the position error limit can be inactive. <input type="checkbox"/> By setting this parameter as "1," detection of the position error limit will be stopped and the operation will be continued even with exceeding deviation counter, not taking it as error condition.
2A	Torque Filter (Time Constant)	0 - 2500	<input type="checkbox"/> Set time constant of the torque filter. <input type="checkbox"/> By making the setting larger, time constant will be increased. <input type="checkbox"/> When changing this parameter, set parameter 05 "Speed detection filter" with 0. <div style="text-align: right;">Unit: (10 μs)</div>
2B	Feed Forward Filter Time Constant	0 - 6400	<input type="checkbox"/> Set time constant of the feed forward filter. <input type="checkbox"/> If parameter 21 "Speed feed forward" is set other than "0," make this parameter 200 or more. <input type="checkbox"/> By making the setting larger, time constant will be increased. <div style="text-align: right;">Unit: (10 μs)</div>

No.	Parameter	Setting range	Function Contents																																				
30	2nd Speed Loop Gain	25 - 3500	<input type="checkbox"/> This is proportional gain of speed loop. By making this setting value larger, the gain will be increased. <input type="checkbox"/> Optimum value of the speed loop gain differs depending on the load inertia and the motor type. <input type="checkbox"/> Switching setting to 2nd gain is performed with parameter No. 33 2nd gain operation setting.																																				
31	2nd Speed Loop Integration Time Constant	1 - 1000	<input type="checkbox"/> This is integration time constant of speed amplifier. By making it smaller, it will be integrated faster. Note) If integration time constant is set to the maximum value (1000) of the setting range, it will be infinite (No integration). <input type="checkbox"/> Switching setting to 2nd gain is performed with parameter No. 33 2nd gain operation setting.																																				
32	2nd Position Loop Gain	0 - 1000	<input type="checkbox"/> Set position gain. Unit of the setting value is (1/s). <input type="checkbox"/> By making the setting value larger, the position gain and the servo stiffness (Typical hardness at servo locking) will be increased. Note) Note that too large setting may cause an oscillation. <input type="checkbox"/> Switching setting to 2nd gain is performed with parameter No. 33 2nd gain operation setting.																																				
33	2nd Gain Operation Setting	0 - 1	<input type="checkbox"/> Set switching mode for 2nd gain setting from parameter No. 30-32. 0: No switching to 2nd gain. 1: Automatic switching to 2nd gain.																																				
34	2nd Gain Switching Delay Time	0 - 10000	<input type="checkbox"/> Set delay time until switching to 2nd gain in case of setting "1" with parameter No. 33. This will be set with the delay time after finishing the command pulse generation. <p style="text-align: right;">Unit: (2.0 ms)</p>																																				
3B	Speed Monitor Signal Selection	0 - 1	<input type="checkbox"/> Select a signal to be outputted to the speed monitor signal (CN I/F 16 pin). 0: Motor speed 1: Position deviation <input type="checkbox"/> For scale of each monitor, select with parameter No. 08.																																				
3D	Sequence at Alarm	0 - 17	<input type="checkbox"/> Set the control pattern to stop the motor when an alarm is generated. <table border="1" style="width: 100%; border-collapse: collapse; text-align: center;"> <thead> <tr> <th>Value</th> <th>Operation in decelerating</th> <th>Operation after stopping</th> </tr> </thead> <tbody> <tr> <td>0</td> <td>DB ON</td> <td>DB ON</td> </tr> <tr> <td>1</td> <td>Free run</td> <td>DB ON</td> </tr> <tr> <td>2</td> <td>DB ON</td> <td>Free run</td> </tr> <tr> <td>3</td> <td>Free run</td> <td>Free run</td> </tr> </tbody> </table> <p>DB: Dynamic brake</p>	Value	Operation in decelerating	Operation after stopping	0	DB ON	DB ON	1	Free run	DB ON	2	DB ON	Free run	3	Free run	Free run																					
Value	Operation in decelerating	Operation after stopping																																					
0	DB ON	DB ON																																					
1	Free run	DB ON																																					
2	DB ON	Free run																																					
3	Free run	Free run																																					
3E	Sequence at servo-off	0 - 145	<input type="checkbox"/> Set the operation pattern at servo-off. <table border="1" style="width: 100%; border-collapse: collapse; text-align: center;"> <thead> <tr> <th>Value</th> <th>Operation in decelerating</th> <th>Operation after stopping</th> <th>Deviation counter</th> </tr> </thead> <tbody> <tr> <td>0</td> <td>DB ON</td> <td>DB ON</td> <td>clear</td> </tr> <tr> <td>1</td> <td>Free run</td> <td>DB ON</td> <td>clear</td> </tr> <tr> <td>2</td> <td>DB ON</td> <td>Free run</td> <td>clear</td> </tr> <tr> <td>3</td> <td>Free run</td> <td>Free run</td> <td>clear</td> </tr> <tr> <td>4</td> <td>DB ON</td> <td>DB ON</td> <td>hold</td> </tr> <tr> <td>5</td> <td>Free run</td> <td>DB ON</td> <td>hold</td> </tr> <tr> <td>6</td> <td>DB ON</td> <td>Free run</td> <td>hold</td> </tr> <tr> <td>7</td> <td>Free run</td> <td>Free run</td> <td>hold</td> </tr> </tbody> </table> <p>DB: Dynamic brake</p>	Value	Operation in decelerating	Operation after stopping	Deviation counter	0	DB ON	DB ON	clear	1	Free run	DB ON	clear	2	DB ON	Free run	clear	3	Free run	Free run	clear	4	DB ON	DB ON	hold	5	Free run	DB ON	hold	6	DB ON	Free run	hold	7	Free run	Free run	hold
Value	Operation in decelerating	Operation after stopping	Deviation counter																																				
0	DB ON	DB ON	clear																																				
1	Free run	DB ON	clear																																				
2	DB ON	Free run	clear																																				
3	Free run	Free run	clear																																				
4	DB ON	DB ON	hold																																				
5	Free run	DB ON	hold																																				
6	DB ON	Free run	hold																																				
7	Free run	Free run	hold																																				

11 Communication Function

MSS*XP Series position driver has a function of performing serial communication with marketed personal computers via RS-232C. With this function, a personal computer can be used as a console. By using a personal computer as a console, various parameters of the position driver and monitoring of the control state can be performed by using a monitor on the personal computer.

11-1 Construction units and software

11-1-1 Construction units

(1) Corresponding hardware

Operation by the following units is confirmed with automatic machine type recognition in the software.

- ① IBM PC/AT or their compatible machines
- ② DOS/V machine
- ③ NEC personal computers, PC-98 series or their compatible machines

Ex.) PC-9801NS/R·NS/T·NA/C·NA, etc.

(2) Corresponding OS

It is confirmed by the following versions of OS which corresponds to the above hardware.

- ① IBM PC/AT machine

MS-DOS 6.2 (J)

- ② DOS/V machine

MS-DOS6.2/V

- ③ In case of using PC98 series

Prepare MS-DOS ver. 3.0 or upper by customers. Incorporate RS-232C control file "RSDRV. SYS" into MS-DOS as the device driver.

Note) When using hardware or OS other than the above, check for it by customers.

11-1-2 Software for communication control (PANATERM)

Prepare PANATERM (option) for MSS*XP.

For the operation method, refer to "PANATERM Instruction Manual" attached to PANATERM.

■ As an option, a cable to connect connector for position driver front panel section with connector for RS-232C of personal computer is prepared.

Note) As it is different from that of MSD series (MSD*X·MSD*Y·MSD*EX), prepare another one.

12 Operation

12-1 Summary of Functions

The position driver performs communication with sequencer I/O by using I/O of connector I/F for executing positioning operation, origin return operation, etc.

Operation command will be assigned by using point assign input (P1IN-P16IN) signal. For the relationship of the point assign input and the operation command, refer to the following table. For executing the command, command type is determined by P1IN - P16IN and then strobe signal is input.

Point No.	P16IN	P8IN	P4IN	P2IN	P1IN	Contents
0 (00H)	H	H	H	H	H	Reset command
1 (01H)	H	H	H	H	L	Transfer to step data 1
2 (02H)	H	H	H	L	H	Transfer to step data 2
3 (03H)	H	H	H	L	L	Transfer to step data 3
4 (04H)	H	H	L	H	H	Transfer to step data 4
5 (05H)	H	H	L	H	L	Transfer to step data 5
6 (06H)	H	H	L	L	H	Transfer to step data 6
7 (07H)	H	H	L	L	L	Transfer to step data 7
8 (08H)	H	L	H	H	H	Transfer to step data 8
9 (09H)	H	L	H	H	L	Transfer to step data 9
10 (0AH)	H	L	H	L	H	Transfer to step data 10
⋮						⋮
27 (1BH)	L	L	H	L	L	Transfer to step data 27
28 (1CH)	L	L	L	H	H	Transfer to step data 28
29 (1DH)	L	L	L	H	L	High-speed jog operation (-direction)*
30 (1EH)	L	L	L	L	H	High-speed jog operation (+direction)*
31 (1FH)	L	L	L	L	L	Origin return command

H indicates contact point open state (0), and L indicates contact point close state (1).

*Jog operation direction can be inverted by parameter.

Setting example) If P8IN, P1IN signals are in contact point close state (1), and other signals are in contact point open state:

$$2^3 + 2^0 = 8 + 1 = 9, \text{ indicating point 9 (09H).}$$

12-2 Initial setting of NC parameter

Before setting various parameters and doing operations, perform the following setting:

- (1) **Setting of MSS*XP coordinate system**

Decide which side of the motor shaft should be rotated in + direction. The coordinate system used by MSS*XP is set by the parameter "Pulse output direction setting."
With parameter 0, + direction is defined as CCW and - direction is defined as CW.
With parameter 1, + direction is defined as CW and - direction is defined as CCW.
Since this parameter becomes active after resetting the power supply and reset the power supply once after setting this parameter.
- (2) **Setting of jog operation direction**

Jog operation direction is set by the parameter "Jog operation direction."
With parameter 0, jog operation is performed in + direction by ←key, and in - direction by →key.
With parameter 1, jog operation is performed in - direction by ←key, and in + direction by →key.
Set jog acceleration/speed, and confirm that jog operation directions are correct by using a console or I/O.
- (3) **Setting of origin return direction**

Origin return direction is set by parameter "Origin return operation direction."
With parameter 0, origin return is performed in + direction, and with parameter 1, origin return is performed in - direction. (Indicating the direction to which the origin vicinity sensor rushes in the end.)
Set acceleration/speed of the origin return, and confirm that origin return direction and origin return position are correct.
- (4) **Setting and confirmation of step operation**

After confirming that the above settings are all correct, input step data of the step operation, set acceleration/speed and then, confirm the step operation.

12-3 Position driver state transition

For this position driver, executable command types are different according to the following three control states.

- Reset state
(state where the present position when turning the power supply on is not determined.)
- Normal state
(state where the present position after finishing origin return is held.)
- Alarm state
(state where alarm is generated and protection function of the position driver is operated.)

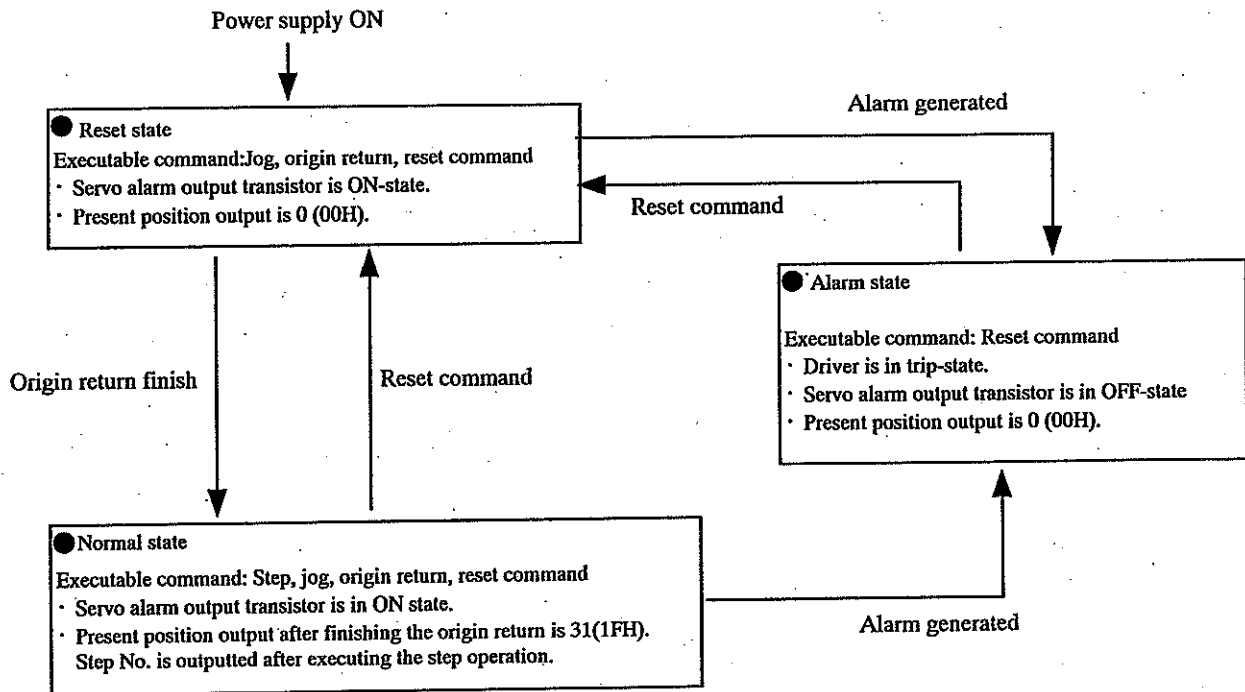

Fig. 12-1 Position driver state transition

12-4 Sequence at power supply input

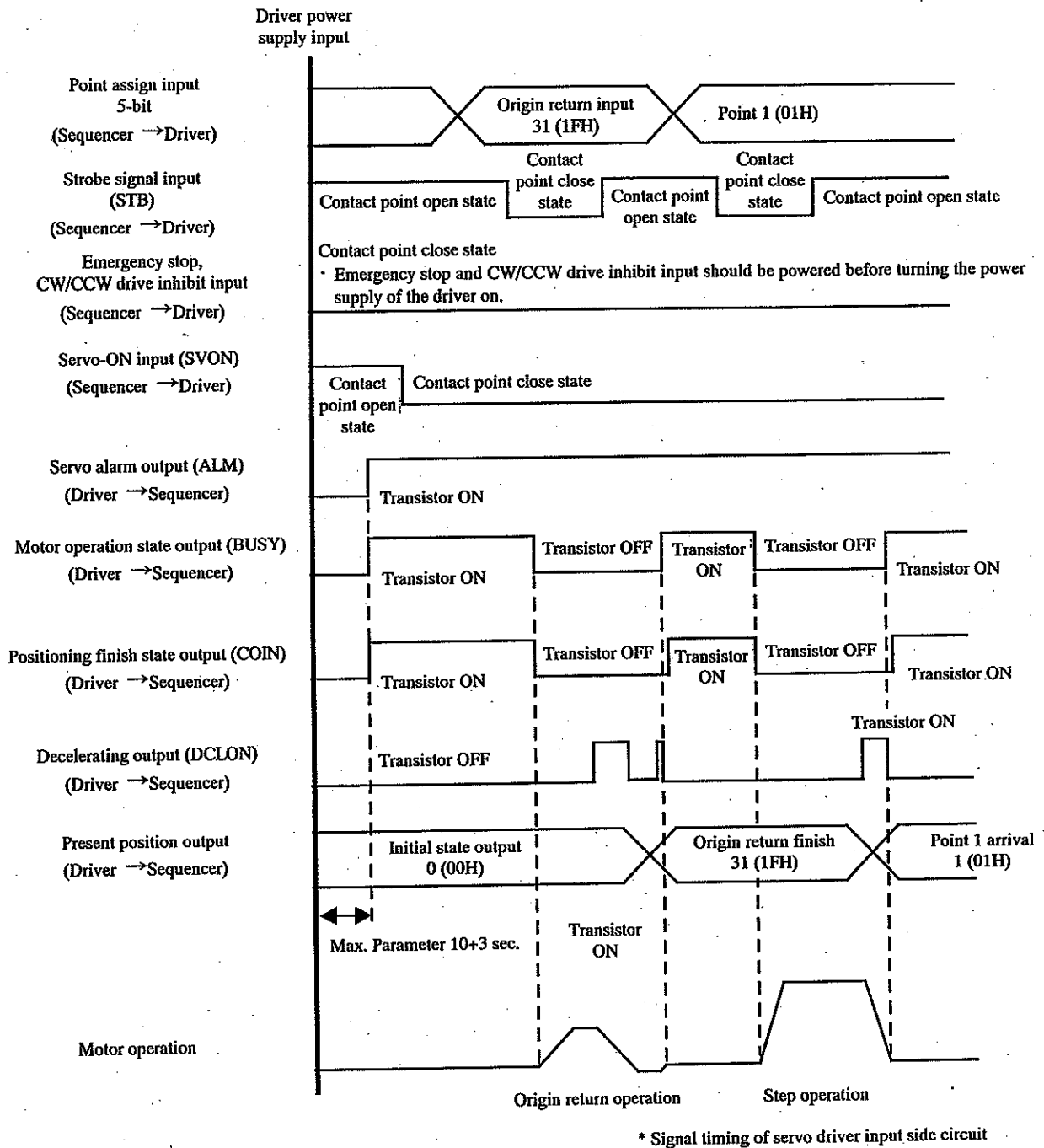

Fig. 12-2 Sequence at power supply input

Note) For the time until the startup of the position driver after turning the power supply on, it is possible to adjust with servo parameter No. 10 "Startup delay time." (Refer to section 10-3 "Details of Servo Parameters (User parameters)" (Page 35).)

12-4-1 Electromagnetic brake release timing

In case of using the motor with an electromagnetic brake for Z-axis elevating (vertical) operation, etc., release the brake under the following timing (=powered).

- (1) In case that servo-on signal input is ON before turning the power supply of the position driver on.
Release the brake after turning the power supply of the driver on, passing servo parameter No. 10 "Startup delay time" + 3 seconds, and confirming that alarm is not generated.
Input strobe signal (STB) after the brake release and 500ms. or more.

- (2) In case that servo-on signal input is ON after turning the power supply of the position driver on.
Release the brake under the condition of turning the power supply of the driver on (Alarm is not generated yet.) and after 1 sec. or more of turning the servo-on signal input on.
Input strobe signal (STB) after the brake release and 500ms. or more.

12-5 Operation specifications

12-5-1 Step command

- (1) Position is transferred to the point assigned by P11N - P16 IN. Information for the transfer must be described in the step data. If transferred to an unregistered step, Step data undefined error (54) will be generated and the motor will be stopped by activating the protection function of the position driver.
- (2) For the operation speed, typical speed data registered in the speed data is used. If unregistered typical speed is referred or acceleration speed is not defined, Speed/acceleration undefined error (52) will be generated and the motor will be stopped by activating the protection function of the position driver.
- (3) If the origin return is in unfinished command after turning the power supply on, it will not be executed even with the step command input.
- (4) If the operation direction limit signal is input during executing the step command, Hardware limit input error (55) will be generated and the motor will be stopped by activating the protection function of the position driver.
- (5) When exceeding the software limit range during executing the step command, Software limit input error (56) will be generated and the motor will be stopped by activating the protection function of the position driver.
- (6) When continuing relative transfer to the same direction, the present position will overflow. When the present position exceeds the range of -1073741824 - 1073741823, Present position overflow error (57) will be generated and the motor will be stopped by activating the protection function of the position driver. Check the step data setting contents and the host controller program contents.
For the option setting of NC parameter, if "Only use relative transfer" is used for positioning method selection, present position overflow error will not be generated. However, the step command will be only for relative transfer. (For details, refer to section 12-8-2 "Positioning method selection" (page 56).)
- (7) When an error is generated in the position driver, the step command cannot be executed unless the reset command is input once and the origin return command is executed.

12-5-2 Jog command

- (1) Jog command continues the operation during the strobe signal input (in contact point close state).
- (2) In jog operation using I/O, low-speed jog operation to be assigned by the typical speed data cannot be performed (Possible only by a console).
- (3) Jog operation direction can be inverted by a parameter.
- (4) In case that operation direction limit signal is inputted during the jog operation in the reset state, only the motor stops. However, in case that the limit signal is inputted during the jog operation in the normal state after finishing the origin return, Hardware limit input error (55) will be generated and the motor will be stopped by activating the protection function of the position driver.
- (5) If the motor position exceeds the software limit range during the jog operation, Software limit error (56) will be generated and the motor will be stopped by activating the protection function of the position driver.
- (6) When continuing the jog operation to the same direction, the present position will overflow. When the present position exceeds the range of -1073741824 - 1073741823, Present position overflow error (57) will be generated and the motor will be stopped by activating the protection function of the position driver.
For the option setting of NC parameter, if "Only use relative transfer" is used for positioning method selection, Present position overflow error will not be generated.
(For details, refer to section 12-8-2 "Positioning method selection" (page 56).)

12-5-3 Origin return command

- (1) Operation specification for the origin return is shown in Fig. 12-3 Origin return operation specification (Page 47).
- (2) If the error limit signal is input during executing the origin return command, Origin return error (51) will be generated and the motor will be stopped by activating the protection function of the position driver.
- (3) Origin offset can be set by a parameter. For details, refer to section 12-8-1 "Origin return offset function" (Page 56).
- (4) For the origin vicinity input, wiring should be performed to connect to COM- at the position before 180 degrees from Z-phase.
- (5) In case of starting the origin return operation from greatly closer position to the origin sensor, note that maximum 1 rotation is found when detecting the last transition of the origin sensor.

12-5-4 Reset command

- (1) Reset command is used to return the position driver to the initial state (reset state) when an alarm of the position driver is generated (Active without generating an alarm).
- (2) If the reset command is executed, the position driver returns to the state found after turning the power supply on.
- (3) By executing the origin return command, step command becomes active.

12-5-5 Emergency stop input

- (1) When inputting the emergency stop, Emergency stop input error (53) will be generated and the motor will be stopped by activating the protection function of the position driver.
- (2) Emergency stop input error will be restored by turning the power supply on again under the initial state. With the state with the option setting for NC parameter, Emergency stop error can be restored with the reset command. (For the setting method, refer to section 10-2-4 "NC data" (Page 33).)

① Performing origin return in CW direction

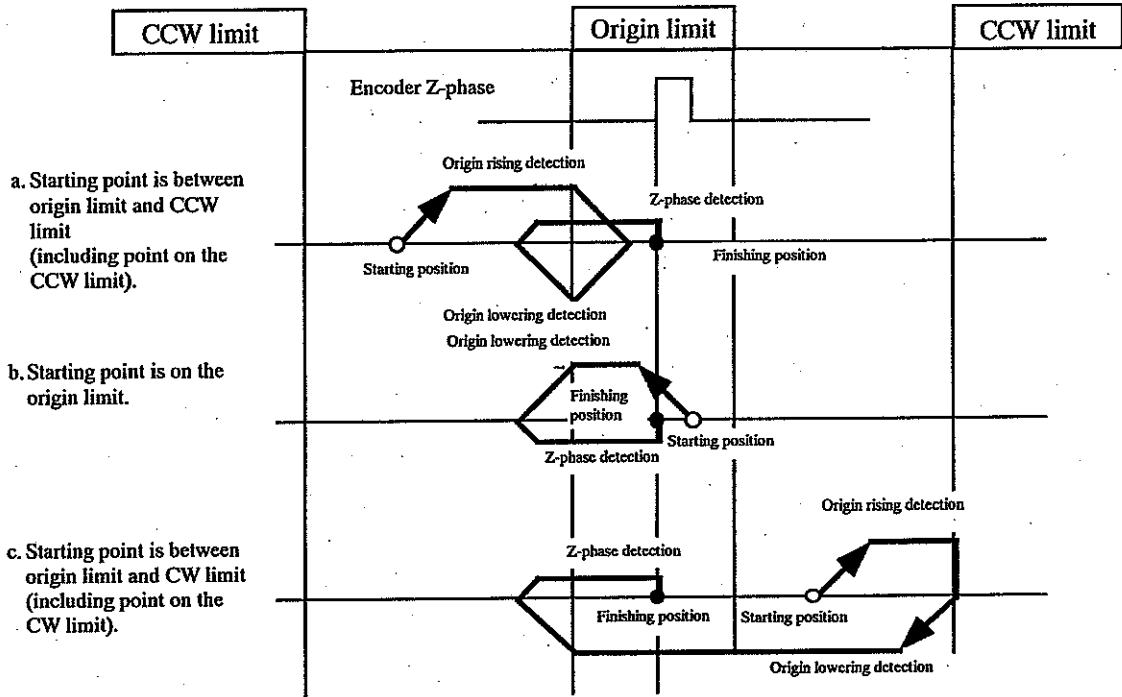

② Performing origin return in CCW direction

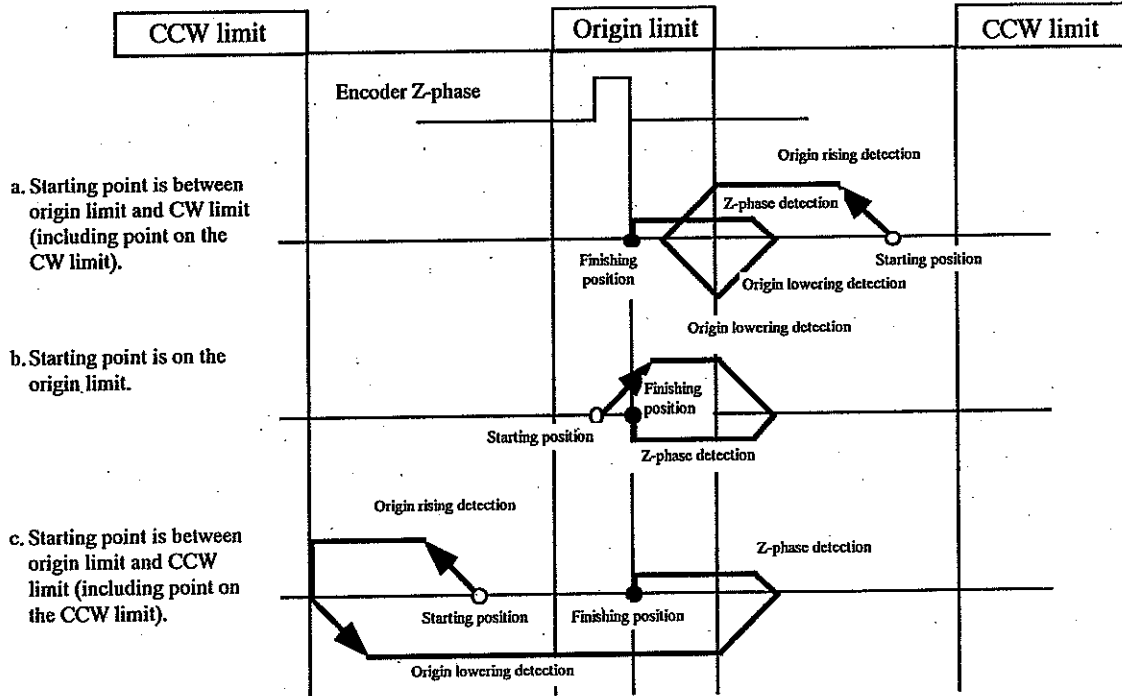

Fig. 12-3 Origin return operation specification

12-6 Interface timing

The timing chart shown below is the one viewed from the position driver side and without using a console. This timing chart is not applicable when using a console. For timing on the sequencer side, perform I/O operation with the position driver, having the margin of a few ms.

12-6-1 Step command, origin return command

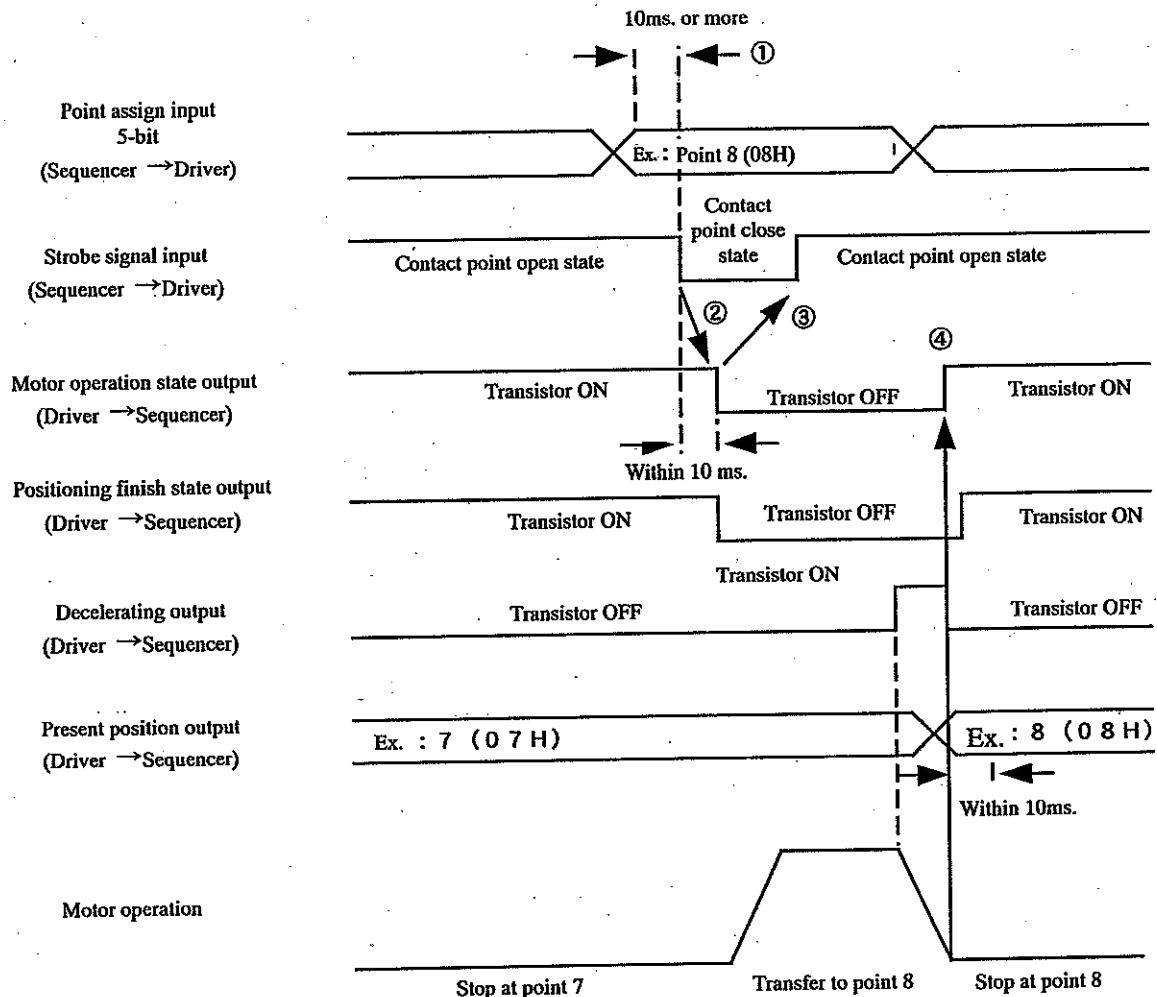

Fig. 12-4 Interface timing (In step operation)

- (1) Next transfer point should be assigned by the sequencer I/O from point assign input signal (P11N - P16IN) (Ex. Point 8).
- (2) After passing 10ms. or more of inputting the point assign, set the strobe signal input (STB) to state connected to COM- from the open state. With this operation, operation command will be inputted to the position driver.
- (3) Within 10ms. after inputting the operation command to the position driver, the transistor of motor operation state output (BUSY) will be turned off, starting the motor operation. After turning the motor operation state output transistor off, return the strobe signal to the open state.
- (4) During the motor deceleration, the transistor of decelerating output (DCLON) is turned on.
- (5) After finishing the motor operation, the motor operation state output transistor will be returned to the ON state. Present position output signal (P1OUT -P16OUT) outputs 8 (08H) within 10ms. The

transistor of the positioning finish state output (COIN) will be turned on when the reserved pulse amount in the deviation counter enters in the parameter No. 22 "Positioning finish range."

- Note1) With regard to positioning finish state output (COIN) and decelerating output (DCLON), decide which signal you use with the option setting for NC parameter. (Refer to section 10-2-4 "NC data" (Page 33).
- Note2) In case that the motor operation is finished while the strobe signal input is not returned to the open state after turning off of the motor operation state output, motor operation state output transistor will not return to the ON state, holding the OFF state. After turning the motor operation state output transistor off, be sure to return the strobe signal to the open state.

12-6-2 Jog command

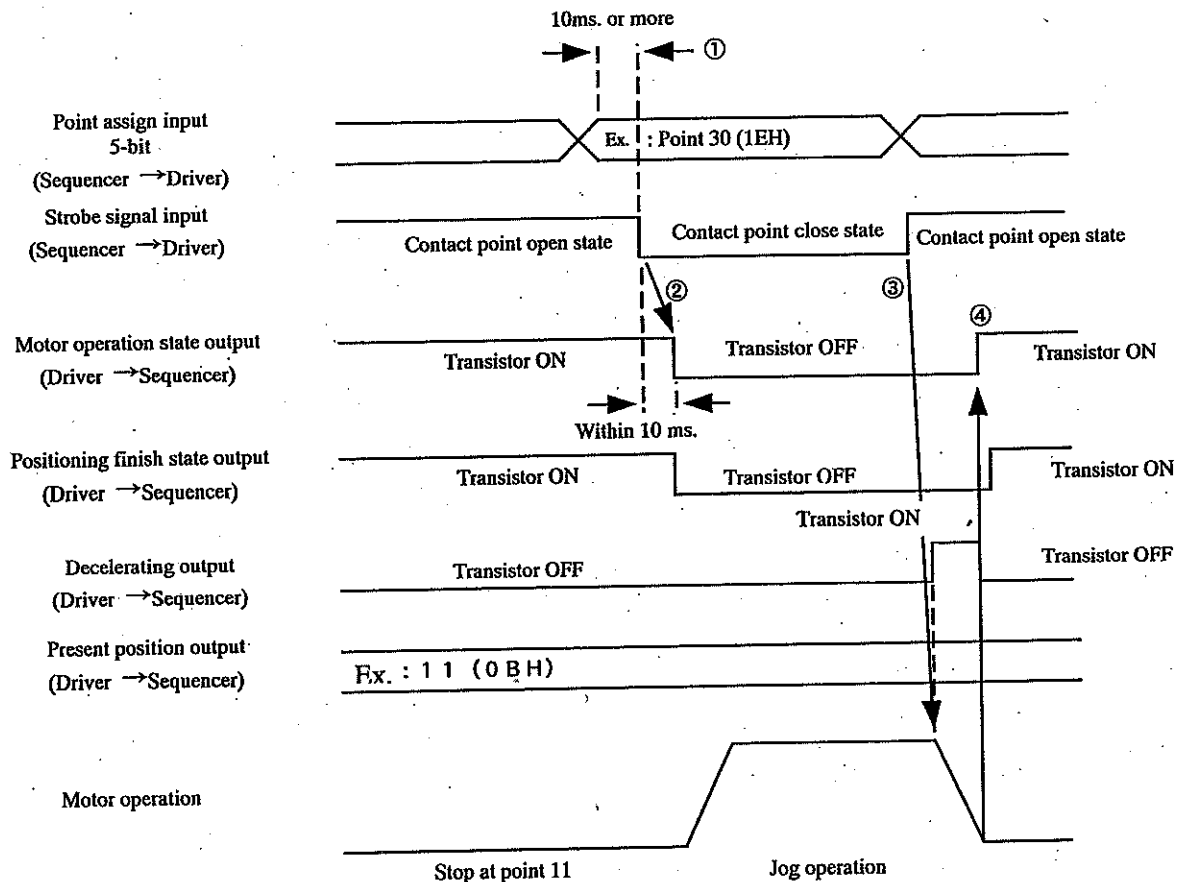

Fig. 12-5 Interface timing (In jog operation)

- (1) Jog command should be assigned by the sequencer I/O from the point assign input signal (P11N - P16IN) (Point 29 or Point 30).
- (2) After passing 10ms. or more of inputting the point assign, set the strobe signal input (STB) to state connected to COM- from the open state. With this operation, jog operation command will be inputted to the position driver.
- (3) Within 10ms. after inputting the operation command to the position driver, the transistor of motor operation state output (BUSY) will be turned off, starting the motor jog operation.
- (4) The jog operation stops in the decelerating speed by returning the strobe input signal to the open state.
- (5) During the motor deceleration, the transistor of decelerating output (DCLON) is turned on.
- (6) After finishing the motor operation, motor operation state output transistor will be returned to the ON

state. Present position output signal (P1OUT -P16OUT) does not change. The transistor of the positioning finish state output (COIN) will be turned on when the reserved pulse amount in the deviation counter enters in the parameter No. 22 "Positioning finish range."

Note 1) With regard to positioning finish state output (COIN) and decelerating output (DCLON), decide which signal you use with the option setting for NC parameter. (Refer to section 10-2-4 "NC data " (Page 33).)

12-6-3 Reset command

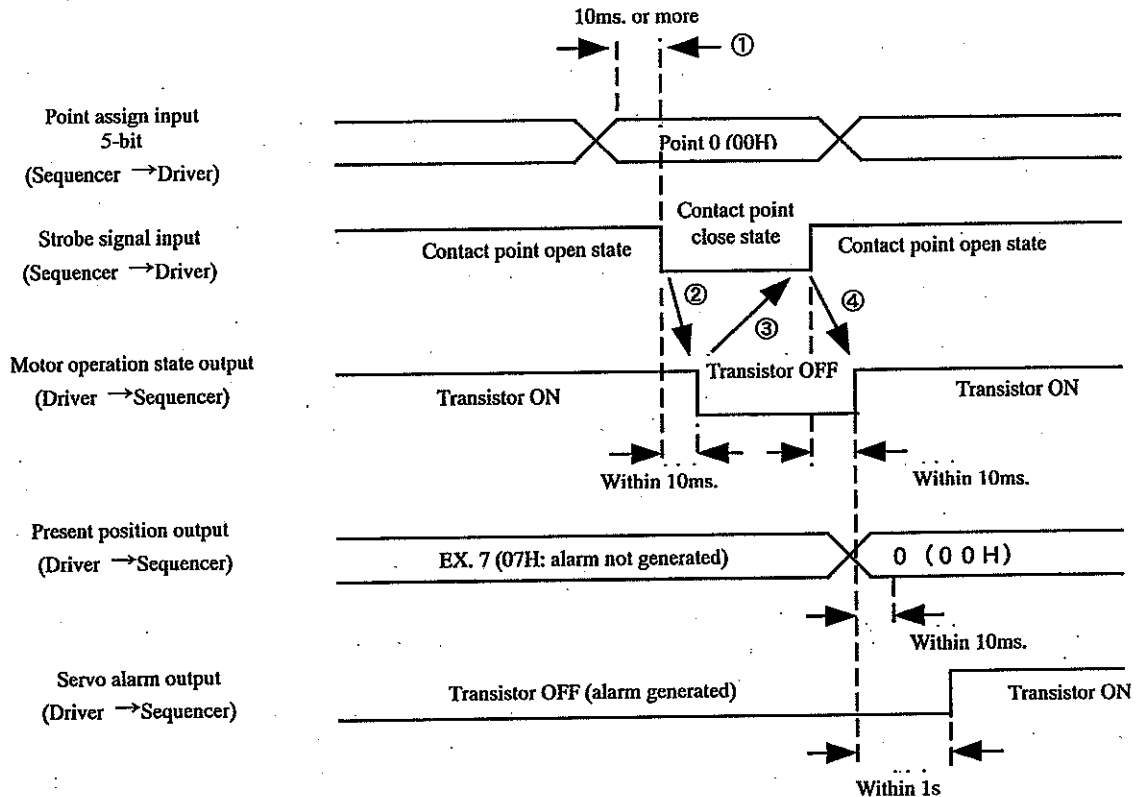

Fig. 12-6 Interface timing (With reset command)

- (1) Reset command (Point 0) should be assigned by the sequencer I/O from the point assign input signal (P11IN - P16IN).
- (2) After passing 10ms or more of inputting the point assign, set the strobe signal input (STB) to state connected to COM- from the open state. With this operation, reset command will be inputted to the position driver.
- (3) Within 10ms after inputting the reset command to the position driver, the transistor of motor operation state output (BUSY) will be turned off. After turning the motor operation state output transistor off, return the strobe input signal to the open state. At the time, reset command is executed.

- (4) Since the reset command is executed instantaneously, if the strobe input signal is returned to the open state, motor operation state output transistor will be returned to the ON state. In case that an alarm is not generated, present position output signal (P1OUT - P16OUT) will be changed to 0 (00H: All transistors are OFF.) within 10ms. If an alarm is cleared normally when the alarm is generated, servo alarm output (ALM) transistor will be turned on within 1 second.

Note) This reset command is a command for returning the position driver to the initial state (Reset state) when an alarm is generated to the position driver (Alarm clear).

12-6-4 Timing when using a console

For interface timing in case of connecting a console, the above timing will not be applicable.

Generally, in case of using a console, the response of the position driver will be delayed. Specifically, in case of using a console monitor function, the response may be greatly delayed. Be careful for the timing when MSS*XP is controlled by I/O while using the console monitor function.

12-7 S-Form acceleration/deceleration function

- With this position driver, S-form acceleration/deceleration is possible when accelerating and decelerating.
- For setting of S-form acceleration/deceleration, it can be performed with NC parameter "S-form acceleration/deceleration setting."
- By changing value of this parameter, pole-change point for S-form acceleration will be changed. The smaller the value, the more rapid the acceleration you can get. The larger the value, the more rapid the reduction of the acceleration you can get (When it is 0 or 10, it will be linear acceleration/deceleration control).

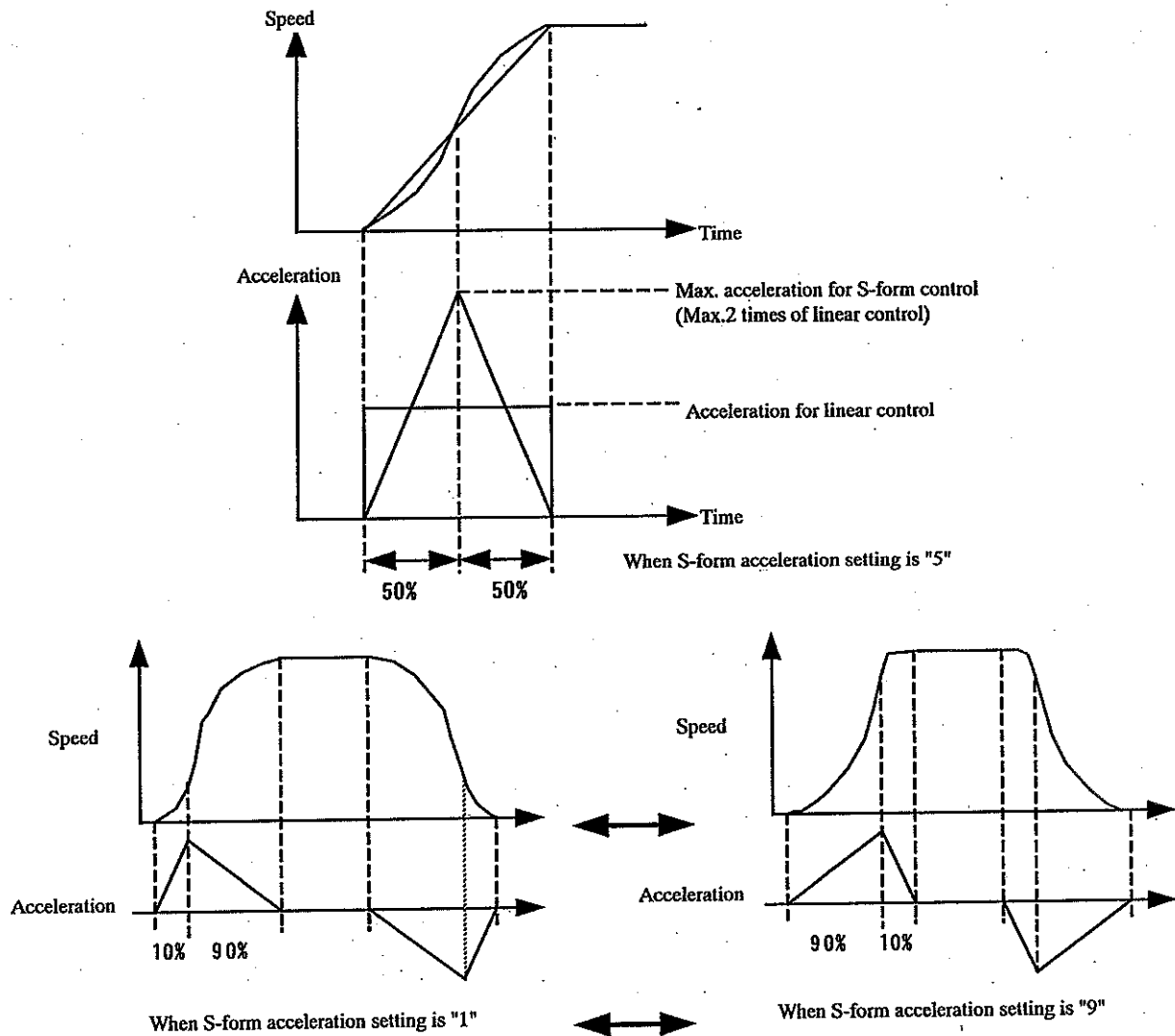

- Note1) In normal case, use S-form acceleration/deceleration setting parameter with "5."
- Note2) S-form acceleration/deceleration on this position driver performs the control with S-form against the acceleration time which has been set. Therefore, as the acceleration time is different from the one for linear acceleration/deceleration, and the maximum acceleration at S-form acceleration/deceleration becomes maximum 2 times of the linear acceleration/deceleration with the same setting, the acceleration torque may be insufficient.
- Note3) S-form acceleration/deceleration may take more positioning time than that of linear acceleration/deceleration.
- Note4) S-form acceleration/deceleration will be applicable only when accelerating with step command and jog command.
- Note5) If the acceleration is moderate and the transfer distance is short, it may not be reached to the maximum speed.

12-8 Special Function

12-8-1 Origin return offset function

Origin return offset function is assigned always by pulse amount from the machine origin (position of the first Z-phase after detecting by the origin vicinity sensor).

When executing the origin return command, operation after stopping at the machine origin position can be set with an option setting for NC parameter. For setting method, refer to section 10-2-4 "NC data" (Page 33).

- If the operation selection at the origin return finish is set to "0," the motor stops at the machine origin position, and present position becomes (-origin offset amount). When moving it to the origin offset position, it is necessary to move to the absolute position 0 with the step command.
- If the operation selection at the origin return finish is set to "1," the motor moves to the origin offset position with the minimum speed (5kpps) after stopping at the machine origin position. The present position after the origin return finish is "0."

Since the origin return offset parameter becomes active after the reset, reset the power supply once after setting this parameter.

- When origin offset amount is set to -5000

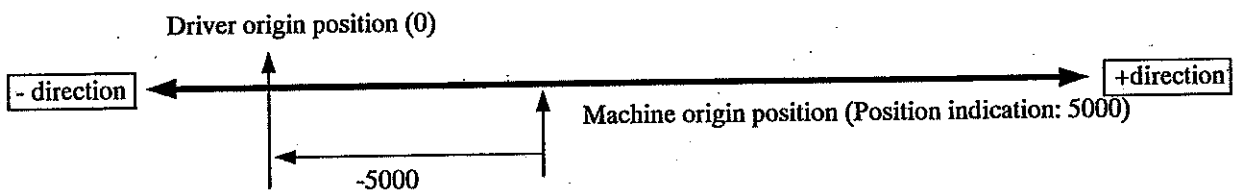

Fig. 12-7 Offset setting example

12-8-2 Positioning method selection

With NC parameter option setting, positioning method of this position driver can be selected. (For setting method, refer to section 10-2-4 "NC data" (Page 33)).

- If positioning method is selected as "Using absolute operation/relative operation," absolute position operation (ABS) and relative position operation (INC) can be performed with the step command. However, if relative transfer is continued to the same direction, the present position will overflow. If the present position exceeds the range of -1073741824-1073741823, present position overflow error (57) will be generated and the motor will be stopped by activating the protection function of the position driver. If you would like to perform positioning at the absolute position in the system structure with definite operation range, it is necessary to define the positioning method as "Using absolute operation/relative operation."
- If positioning method is selected as "Only using relative operation," only relative position operation is executable. In this case, Present position overflow error will not be generated even with the overflow for the present position (Present position overflow error becomes inactive). In case of system structure in which the operation is continued only in the same direction, it is necessary to define the positioning method as "Only using relative operation."

12-8-3 Control state selection at servo-off

With NC parameter option setting, control state at the servo-off of this position driver can be selected. (For setting method of parameter, refer to section 10-2-4 "NC data" (Page 33)).

- If set as "Normally reset state at the servo-off" (0) (Initial setting state), control state of the position driver will be transferred to the reset state (State without doing the origin return) when turning the servo-on signal off (servo-off) under the normal state (State that origin return is finished).
To perform the step operation with servo-on after the servo-off state, the origin return operation must be done again.
- If set as "Hold the present state at the servo-off" (1), control state at the servo-on (Normal state) can be held even with servo-off.
At the time, set as "Hold the deviation counter" for servo parameter 1E "Sequence at the servo-off."
By performing this setting, the motor will be operated for the deviation counter when turning servo-on again to hold the deviation counter value under the servo-off state, and the motor will try to return to the position of servo-on.

- As the transfer is made only for the deviation counter at the servo-off, pay attention for the safety.
- If the deviation counter amount at the servo-off is too large, as the motor is operated abruptly at the servo-on, overcurrent error, overload error, deviation counter error, etc. may be occurred. In such case, do not use this function.

12-8-4 Torque output selection at limit signal input

With NC parameter option setting, operation method at the limit signal input can be selected. (For setting method, refer to section 10-2-4 "NC data" (Page 33)).

- If set as "Torque output inhibit for limit signal input direction" (0) (Initial setting state), torque will not be outputted in the direction with the limit signal open.
- If set as "Torque output allowed for limit signal input direction" (1), it will be in the servo-lock state with the limit signal open. Torque in the direction will be outputted, but will not be operated.

Note) The above setting becomes active only when the origin return is not finished (Reset). If the limit signal for the operation direction is opened (In case of drive inhibit state) at the origin return finish (Normal state), Hardware limit error (55) will be generated and the position driver will be tripped.

- In case of using this function, use only when doing adjustment. Even if the limit signal is opened, pay enough attention for the safety as the torque will be outputting continuously.

13 Key Operation on the Front Panel

13-1 Description of each key

Key	Name of key	Function of key
[MODE]	MODE key	<input type="checkbox"/> Switches the mode.
[SET]	SET key	<input type="checkbox"/> Switches between selection display state and execution display state.
[↑][↓]	CURSOR key	<input type="checkbox"/> When the decimal point is flashing, Changes the data and selects the parameter. <input type="checkbox"/> When inputting the step data, For teaching operation to input the coordinate data (Only when finishing the origin return)
[←]	SHIFT key	<input type="checkbox"/> When the decimal point is flashing, Moves a digit for the data change to the upper digit. <input type="checkbox"/> When inputting the step data, Cancels the input data. <input type="checkbox"/> When conducting test operation, Executes the test operation

13-2 Summary of operation

- In case of operating with key switches on the front panel section or LED, there are 9 kinds of modes: monitor mode, step data edit mode, speed data edit mode, NC data edit mode, offset data edit mode, servo parameter edit mode, EEPROM writing mode, automatic gain tuning mode, and test operation mode. When switching with these modes, [MODE] switch is used. There are selection display and execution display for each mode, and [SET] switch is used for switching these two displays. For selection or execution in each mode, there are 3 key switches., [↑][↓], or [←] to perform the operation.
- In the display, the digit displaying the flashing decimal point is possible for the data change, and these [↑], [↓] and [←] keys are inactive if it is not displayed
- When turning the power supply on, the contents selected with servo parameter No. 01 "LED initial display" will be displayed.
- If the position driver is tripped, the front panel display will be forced to be a display with the error factor, flashing all digits.
- When a special console is connected to the position driver, the front panel cannot be used.

Mode	Item	Page	Function
Monitor mode	Position deviation monitor	60	<input type="checkbox"/> Displays the state of the present deviation pulse.
	Speed monitor	61	<input type="checkbox"/> Displays the present speed.
	Torque monitor	61	<input type="checkbox"/> Displays the present torque output.
	ID No. display	61	<input type="checkbox"/> Displays the ID No. set in the position driver.
	The present position monitor	62	<input type="checkbox"/> Displays the present position of the motor.
	Input/output signal monitor	62	<input type="checkbox"/> Displays the state of the input/output signal. (ON/OFF)
	Error No. display	63	<input type="checkbox"/> Displays the error No. currently generated, or error records in the past.
	Parameter display used by the manufacturer	63	
Step data edit mode		64	<input type="checkbox"/> Sets and changes data for positioning.
Speed data edit mode		66	<input type="checkbox"/> Sets and changes positioning speed, origin return speed, and jog speed
NC data edit mode		67	<input type="checkbox"/> Sets and changes acceleration data, operation direction setting, S-form control setting, input/output signal logic, etc.
Offset data edit mode		68	<input type="checkbox"/> Sets and changes origin offset and software limit.
Servo parameter edit mode		69	<input type="checkbox"/> Sets and changes servo parameters such as gain for the position driver.
EEPROM writing mode		71	<input type="checkbox"/> Writes parameters into EEPROM to make them active even after resetting the power supply.
Automatic gain tuning		72	<input type="checkbox"/> Executes the automatic gain tuning.
Test operation		73	<input type="checkbox"/> Executes jog operation, origin return operation, step No., etc.

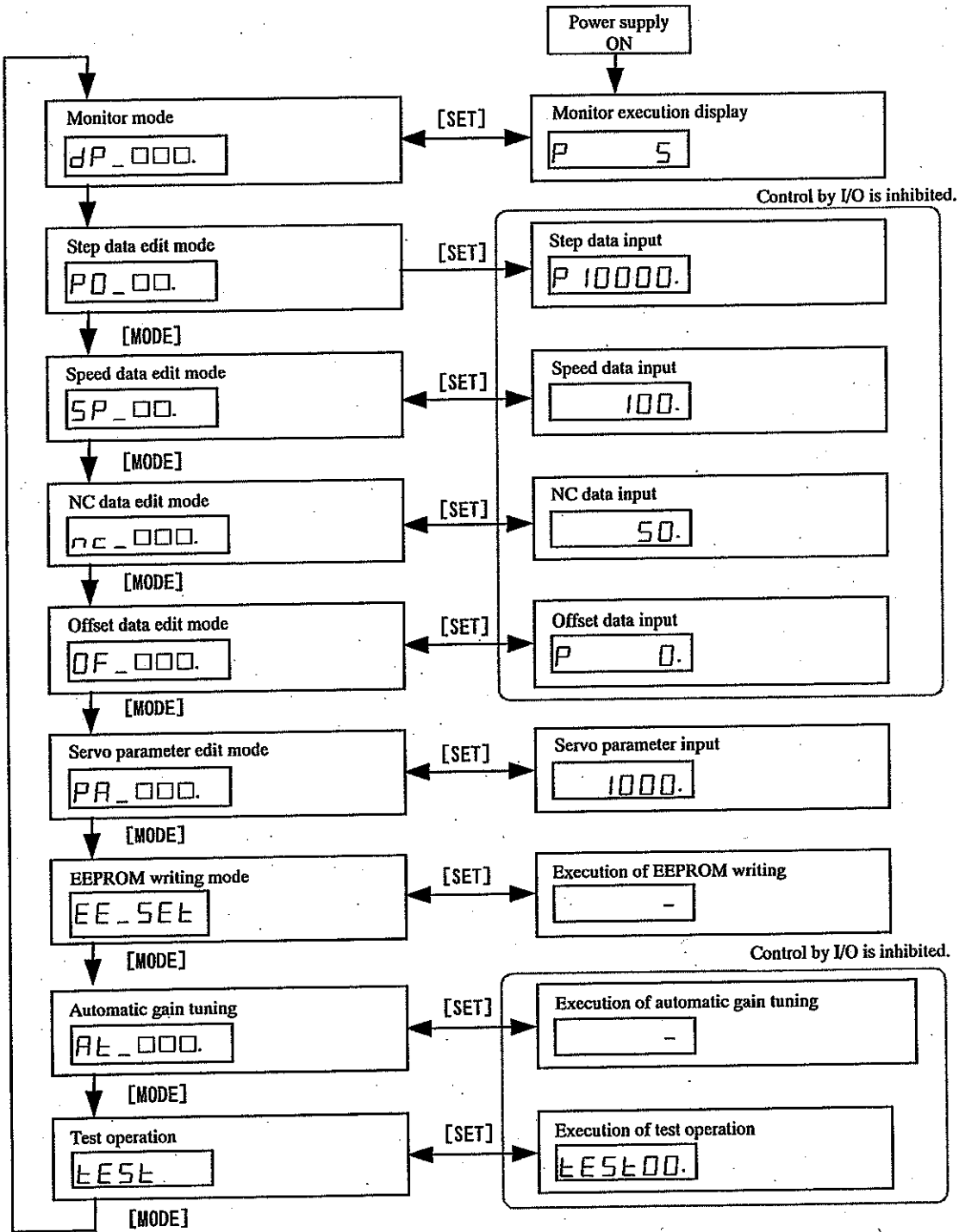
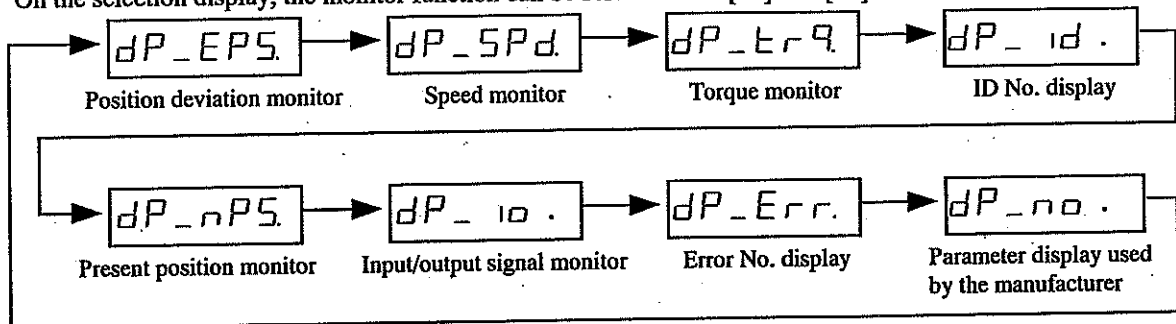

Fig. 13-1 Outline of operation

13-3 Details of operation

13-3-1 Monitor mode

- When turning the power supply on, and after the LED check, there will be an execution display of the monitor mode in accordance with the setting of parameter No. 01 "LED initial setting" (Position deviation, motor rotation speed, torque output, ID NO. display, present position monitor, input/output signal monitor, error No. display, or parameter display used by the manufacturer).
- When an error is generated in the position driver, display on the front panel will be indicating the error No., flashing the front panel regardless of any condition.
- For the monitor mode, there are selection display and execution display for the monitor function. Selection display and execution display can be switched with [SET].
- On the selection display, the monitor function can be selected with [↑] and [↓].



- If pressed with [↑], the display will be changed in the arrow direction, and in the reverse direction if [↓] is pressed.

13-3-1-1 Position deviation monitor

- Displays the reserved pulse amount for the deviation counter.

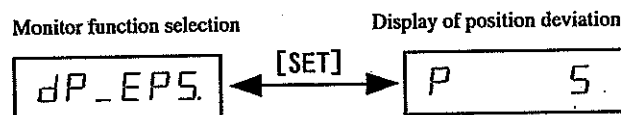

- Unit for the display is (pulse).
 - (+) : Generates the motor torque in the CCW direction.
 - : Generates the motor torque in the CW direction.
- Note1) If the polarity is (+), + sign will not be displayed.
- Note2) Data will be indicated only until the last 6 digits. If the display data is more than 6 digits, "P" will not be displayed.
- By pressing [SET], monitor selection display and position deviation display will be switched.
 - If [↑] is pressed on the monitor function selection display, it will be moved to the monitor function selection display of the speed monitor.
 - If [↓] is pressed, it will be moved to the monitor function selection display for the parameter used by the manufacturer.
 - If [MODE] is pressed on the monitor function selection display, it will be moved to the step data edit mode.

13-3-1-2 Speed monitor

- Displays the motor rotation speed.



- Unit for the display is (kpps).
- (+): Generates the motor torque in the CCW direction.
- : Generates the motor torque in the CW direction.
- Note) If the polarity is (+), + sign will not be displayed.
- By pressing [SET], monitor selection display and speed display will be switched.
- If [↑] is pressed on the monitor function selection display, it will be moved to the monitor function selection display of the torque monitor.
- If [↓] is pressed, it will be moved to the monitor function selection display of the position deviation monitor.
- If [MODE] is pressed on the monitor function selection display, it will be moved to the step data edit mode.

13-3-1-3 Torque monitor

- Displays the motor output torque.



- (+) : Generates the motor torque in the CCW direction.
- - : Generates the motor torque in the CW direction.
- The relationship of the actual generated torque and the displayed value is indicated in the following formula:

$$\text{Torque output (\%)} = \text{displayed value} \times 0.2$$
- Note) If the polarity is (+), + sign will not be displayed.
- By pressing [SET], monitor selection display and torque display will be switched.
- If [↑] is pressed on the monitor function selection display, it will be moved to the monitor function selection display of the ID No. monitor.
- If [↓] is pressed, it will be moved to the monitor function selection display of the speed monitor.
- If [MODE] is pressed on the monitor function selection display, it will be moved to the step data edit mode.

13-3-1-4 ID No. display

- Displays the ID No. set in the position driver.



- By pressing [SET], monitor selection display and ID No. display will be switched.
- If [↑] is pressed on the monitor function selection display, it will be moved to the monitor function selection display of the torque display monitor.
- If [↓] is pressed, it will be moved to the monitor function selection display of the present position monitor.
- If [MODE] is pressed on the monitor function selection display, it will be moved to the step data edit mode.

13-3-1-5 The present position monitor

- Displays the present position of the motor.



- Unit for the display is (pulse).

Note1) If the polarity is (+), + sign will not be displayed.

Note2) If the state is that the origin return is not finished, the present position will be displayed as "P....".

Note3) Data will be indicated only until the last 6 digits. If the display data is more than 6 digits, "P" will not be displayed.

- By pressing [SET], monitor selection display and present position display will be switched.
- If [↑] is pressed on the monitor function selection display, it will be moved to the monitor function selection display of the input/output signal monitor.
- If [↓] is pressed, it will be moved to the monitor function selection display of the ID No. display.
- If [MODE] is pressed on the monitor function selection display, it will be moved to the step data edit mode.

13-3-1-6 Input/output signal monitor

- Displays the state of the control input/output signal.



Note1) With the input signal monitor ("In-"), the signal displaying "R" indicates the contact point close state. With the point assign input ("In-7"), the state of 5-bit input signal is indicated in decimal number.

Note2) With the output signal monitor ("ot-"), the signal displaying "R" indicates that the output transistor is turned on. With the present position output ("ot-3"), the state of 5-bit output signal is displayed in decimal number.

- By pressing [SET], monitor selection display and input/output signal display will be switched.
- By pressing [↑] and [↓] on the input/output signal display, select a signal you would like to refer to.
- If [↑] is pressed on the monitor function selection display, it will be moved to the monitor function selection display of the present position monitor.
- If [↓] is pressed, it will be moved to the monitor function selection display of the error No. display.

- Signal No. and signal name

Signal No.	Signal name	Symbol	CN I/F pin NO.
IN-0	CW drive inhibit input	CWL	29
IN-1	CCW drive inhibit input	CCWL	30
IN-2	Origin vicinity input	ORGL	13
IN-3	Servo-on signal input	SVON	12
IN-4	Strobe signal input	STB	10
IN-5	Emergency stop input	EMG	9
IN-6	Console emergency stop input	-	-
IN-7	Point assign input (Note)	P-IN	35·34·33·32·31
Ot-0	Servo alarm output	ALM	26
Ot-1	Positioning finish output/Decelerating output	COIN/DCLON	25
Ot-2	Motor operation state output	BUSY	27
Ot-3	Present position output (Note)	P-OUT	24·23·17·15·14

Note) For point assign input and present position output, the state of 5-bit input signal is indicated in decimal number.

13-3-1-7 Error No. display

- Displays error factors back to the past 8 errors including the present one.

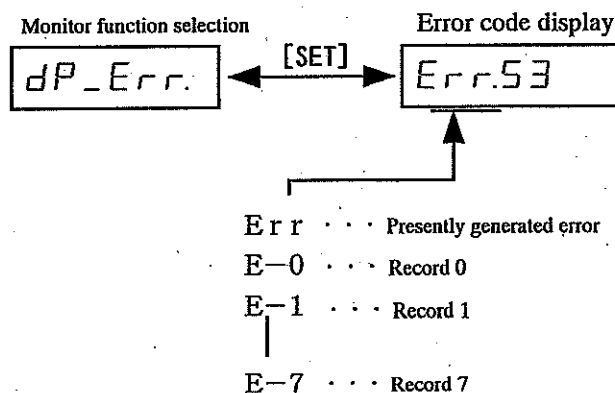

Note1) When no error is generated, the error code will be shown as "--."

Note2) If an error to be remained in the record is generated in the position driver, the presently generated error and record 0 will be displaying the same error code.

- By pressing [SET], monitor selection display and ID No. display will be switched.
- By pressing [↑] and [↓] on the error code display, select a record No. you would like to refer to (If [↓] is pressed, it will be moved to older record)
- If [↑] is pressed on the monitor function selection display, it will be moved to the monitor function selection display of the input/output signal monitor.
 If [↓] is pressed, it will be moved to the monitor function selection display of the parameter display used by the manufacturer.
- If [MODE] is pressed on the monitor function selection display, it will be moved to the step data edit mode.

13-3-1-8 Parameter display used by the manufacturer

- Displays the parameter values used by the manufacturer.

13-3-2 Step data edit

■ Sets and changes the step data to be necessary when executing the positioning operation.

Note1) For positioning coordinate input, only teaching can be used. In case of inputting value directly, use a special console (option) or personal computer software (option).

Note2) To perform teaching for the positioning coordinate, the origin return must be done. In case of referring to the step data, the origin return has not to be done.

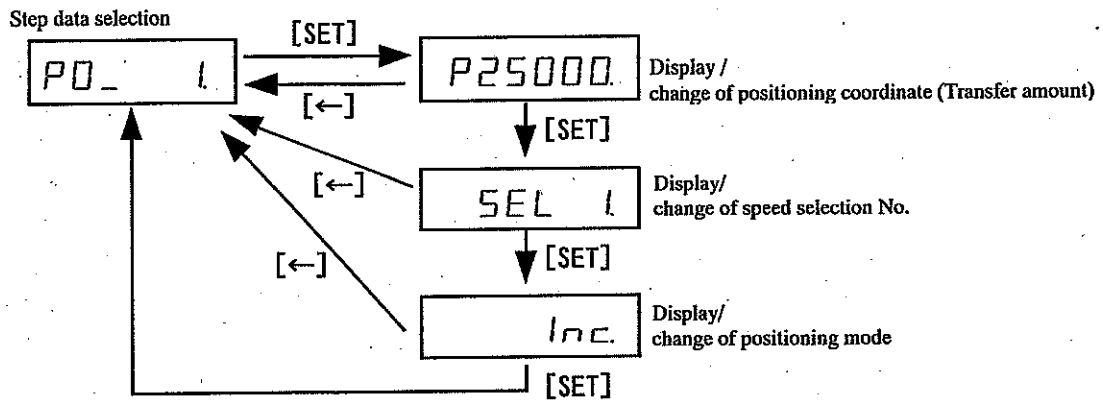

- The step data includes positioning coordinate (Transfer amount), speed selection NO. and positioning mode.
- Input will be switched every time [SET] is pressed. If [←] is pressed, data during the setting will be canceled and it will be moved to the step data No. selection display. The step data will be set at the time of pressing [SET] after finishing the positioning mode input. If [←] is pressed prior to that, step data inputted by then will be all canceled.
- To make the setting data active even after cutting the power supply, data must be written into EEPROM. For data writing into EEPROM, refer to section 13-3-7 "EEPROM writing" (Page 71).

13-3-2-1 Input of positioning coordinate

(1) Select a step data No. you would like to refer to or set.

By pressing [↑] and [↓] on the step data selection display, select a step data No. you would like to refer to or set.

After selecting the step data, press [SET]. It will be the positioning coordinate input display, and the present positioning coordinate will be displayed.

Note) Data will be indicated only until the last 6 digits. If the display data is more than 6 digits, "P" will not be displayed.

(2) On the positioning coordinate input display, input the coordinate data by teaching (Possible only when finishing the origin return).

If [↑] and [↓] are pressed, the motor will be operated with the speed set with the high (speed) jog speed.

If the coordinate position is determined, press [SET]. It will be moved to the speed selection No. input display.

If [←] is pressed, the input will be canceled, returning to the step data selection display.

13-3-2-2 Input of speed selection No.

On the speed selection No. input display, select the speed No. by pressing [↑] and [↓].

If the speed selection No. is determined, press [SET]. It will be moved to the positioning mode selection display.

If [←] is pressed, the input will be canceled, returning to the step data selection display.

13-3-2-3 Selection of positioning mode

On the positioning mode selection display, select the positioning mode by pressing [↑] and [↓] ("A65: Absolute position, "Inc": Relative position).

If the positioning mode is determined, press [SET]. All step data will be set, and it will be moved to the step data selection display.

If [←] is pressed, the input will be canceled, returning to the step data selection display.

13-3-3 Speed data edit

- Sets and changes the reference speed, the origin return speed, and the jog speed to be used for the step operation.

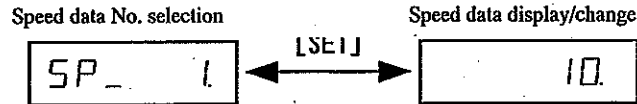

- By pressing [SET], speed data No. selection display and speed data display/change display will be switched.
- On the speed data No. selection display, it will be moved to NC data edit mode by pressing [MODE].
- To make the setting data active even after cutting the power supply, the data must be written into EEPROM.

For data writing into EEPROM, refer to section 13-3-7 "EEPROM writing" (Page 71).

Speed data are listed in the following order.

Speed No.	Speed data	Function	Setting range
1	ORIGIN SPEED	Origin return speed	5 - 500 (kpps)
2 - 11	STEP SPEED No. 01 - 10	Step operation reference speed 1 - 10	
12	JOG SPEED (LOW)	Jog speed (low speed)	
13	JOG SPEED (HIGH)	Jog speed (high speed)	

For details of parameters, refer to section 10-2-2 "Speed data" (Page 32).

- (1) Select speed data No. you would like to refer to or set.

By pressing [↑] and [↓] on the speed data No. selection display, select a speed data No. you would like to refer to or set.

If you selected the speed data No. you would like to refer to or set, press [SET]. It will be the speed data display/change display, displaying the speed data value.

- (2) Change value of the speed data.

By pressing [↑] and [↓], a value of digit indicating decimal number can be changed.

By pressing [↑], the value will be increased and decreased by pressing [↓].

If you press[←], the position of decimal point can be moved to the upper digit.

By pressing [SET], the speed data will be changed, returning to the speed data No. display.

13-3-4 NC data edit

- Sets and changes the acceleration, the operation direction, the S-form control setting, and the input logic.

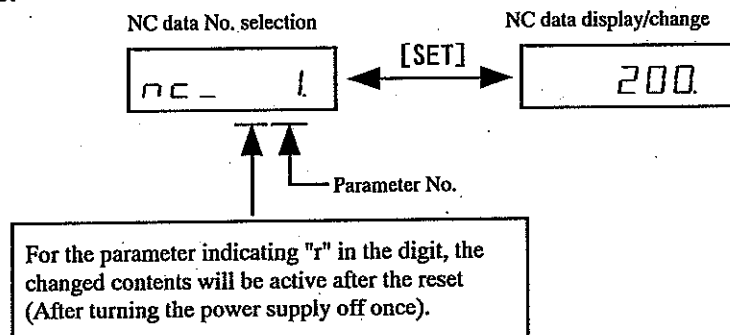

- By pressing [SET], NC data No. selection display and NC data display/change display will be switched.
- On the NC data No. selection display, it will be moved to the offset data edit mode if [MODE] is pressed.
- To make the setting data active even after cutting the power supply, the data must be written into EEPROM.

For data writing into EEPROM, refer to section 13-3-7 "EEPROM writing" (Page 71).

NC data are listed in the following order.

Data No.	NC data	Function	Setting range
1	STEP Acc Time	Step operation acceleration/deceleration time	10 - 10000 (ms)
2	JOG Acc Time	Jog operation acceleration/deceleration time	10 - 10000 (ms)
3	ORG Acc Time	Origin return acceleration/deceleration time	10 - 10000 (ms)
4	JOG dir	Jog operation direction	0 - 1
5	ORG dir	Origin return direction	0 - 1
6	PLS dir	Pulse output direction setting	0 - 1
7	Teaching Step Pulse	Teaching transfer amount setting	0 - 32767
8	S-Curve rate	S-form acceleration/deceleration setting	0 - 10
9	INPUT Logical	Input logic setting	0 - 8063
10	Option	Option setting	0 - 123

For details of step operation acceleration/deceleration time, jog operation acceleration/deceleration time, origin return acceleration/deceleration time, input logic setting, and option setting, refer to section 10-2-4 "NC data" (Page 33). For details of S-form control setting, refer to section 12-7 "S-Form acceleration/deceleration function" (page 55). For setting of jog operation direction, origin return direction, and pulse output direction, refer to section 12-2 "Initial setting of NC parameter" (Page 41).

- (1) Select NC data No. you would like to refer to or set.

By pressing [↑] and [↓] on the NC data No. selection display, select a NC data No. you would like to refer to or set.

If you selected the NC data No. you would like to refer to or set, press [SET]. It will be the NC data display/change display, displaying the NC data value.

- (2) Change value of the NC data.

By pressing [↑] and [↓], value of digit indicating decimal number can be changed.

By pressing [↑], the value will be increased, and decreased by pressing [↓].

If you press [←], the position of decimal point can be moved to the upper digit.

By pressing [SET], the NC data will be changed, returning to the NC data No. display.

13-3-5 Offset data edit

■ Sets and changes the origin offset and the software limit.

Note1) For offset coordinate input, only teaching can be used. In case of inputting a value directly, use a special console (option) or personal computer software (option).

Note2) To perform teaching for the offset coordinate, the origin return must be done. In case of referring to the offset data, the origin return has not to be done.

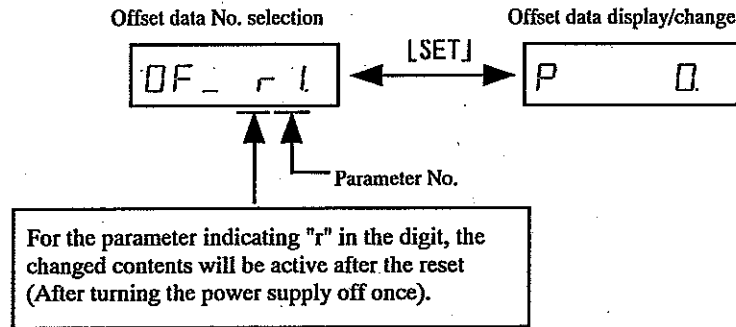

- Offset data is set at the time of pressing [SET]. If [←] is pressed, offset data inputted by then will be canceled.
 - To make the setting data active even after cutting the power supply, the data must be written into EEPROM.
- For data writing into EEPROM, refer to section 13-3-7 "EEPROM writing" (Page 71).

Offset data are listed in the following order.

Data No.	Offset data	Function	Setting range
1	Origin Offset	Origin offset	-1073741824 - 1073741823 (pulse)
2	Soft Limit (PLUS)	+ direction software limit	0 - 1073741823 (pulse)
3	Soft Limit (MINUS)	-direction software limit	-1073741824 - 0 (pulse)

For details and setting range of each parameter, refer to section 10-2-3 "Offset data" (Page 32).

13-3-5-1 Input of offset coordinate

(1) Select offset data No. you would like to refer to or set.

By pressing [↑] and [↓] on the offset data selection display, select a offset data No. you would like to refer to or set.

After selecting the offset data, press [SET]. It will be the offset coordinate input display, and the present offset coordinate will be displayed.

Note) Data will be indicated only until last 6 digits. If the display data is more than 6 digits, "P" will not be displayed.

(2) On the offset coordinate input display, input coordinate data by teaching (Possible only when finishing the origin return).

If [↑] and [↓] are pressed, the motor will be operated at the speed set with the high (speed) jog speed.

If the coordinate is determined, press [SET]. Offset data will be set, moving to the offset data selection display.

If [←] is pressed, the input will be canceled, returning to the offset data selection display.

13-3-6 Servo parameter edit

- Sets and changes servo parameters for the position driver.

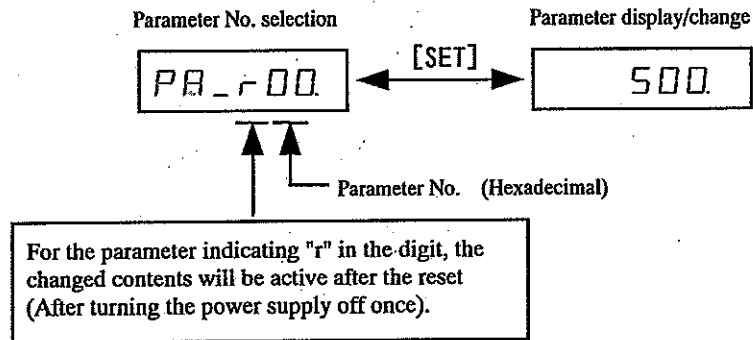

- By pressing [SET], parameter No. selection display and parameter display/change display will be switched.
- If [MODE] is pressed on the parameter No. selection display, it will moved to the EEPROM writing mode.
- To make the setting data active even after cutting the power supply, the data must be written into EEPROM.

For data writing into EEPROM, refer to section 13-3-7 "EEPROM writing" (Page 71).

Servo parameters are listed in the following order.

Data No.	Servo parameters name	Setting range
00	Name of axis	0 - 31
01	LED initial display	0 - 7
03	Speed loop gain	25 - 3500
04	Speed loop integration time constant	1 - 1000
05	Speed detection filter	0 - 4
06	Torque limit setting	0 - 400
08	Speed monitor gain selection	0 - 1
09	Inactive drive inhibit input	0 - 1
0A	Sequence at drive inhibit input	0 - 1
10	Startup delay time	0 - 600
20	Position loop gain	0 - 1000
21	Speed feed forward	0 - 100
22	Positioning end range	0 - 32766
23	Position error limit setting	1 - 32766
24	Cancel of position error limit	0 - 1
2A	Torque filter time constant	0 - 2500
2B	Feed forward filter time constant	0 - 6400
30	2nd speed loop gain	25 - 3500
31	2nd speed loop integration time constant	1 - 1000
32	2nd position loop gain	10 - 1000
33	2nd gain operation setting	0 - 1
34	2nd gain switching delay time	0 - 10000
3B	Speed monitor signal selection	0 - 1
3D	Sequence in alarming	0 - 3
3E	Sequence at the servo-off	0 - 7

For details and setting contents of each parameter, refer to section 10-3 "Details of Servo Parameters (User parameters)" (Page 35).

(1) Select parameter No. you would like to refer to or set.

By pressing [↑] and [↓] on the parameter selection display, select a parameter No. you would like to refer to or set.

If you selected the parameter No. you would like to refer to or set, press [SET]. It will be the parameter display/change display, displaying the parameter value.

(2) Change value of the parameter.

By pressing [↑] and [↓], a value of digit indicating decimal point can be changed.

By pressing [↑], the value will be increased and decreased by pressing [↓].

If [←] is pressed, the position of the decimal point can be moved to the upper digit.

By pressing [SET], the parameter will be immediately changed, and the contents will be reflected against the motor control.

Note1) For the number of digit for moving decimal point position to the upper digit, it is limited for each parameter.

Note2) For change of value for parameters which affect greatly to the motor operation (Especially, speed loop gain, position loop gain, etc.), do not change the value excessively at once, and perform the change little by little. Also, input of [←] (shift key) may be inhibited depending on the parameter.

13-3-7 EEPROM writing

- Writes setting parameter (NC parameter, servo parameter) into EEPROM.

Without writing into EEPROM, it will be returned to the parameter at the time of previous power supply input when resetting the power supply.

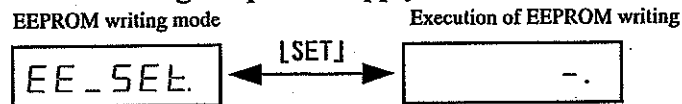

- By pressing [SET], EEPROM writing mode display and writing execution display are switched.
- On EEPROM writing display, it will be returned to the automatic gain tuning mode if [MODE] is pressed.

(1) Press [SET] and go to EEPROM writing execution display.

(2) On the writing execution display, writing will be started when "StArT" is displayed by pressing [↑] continuously.

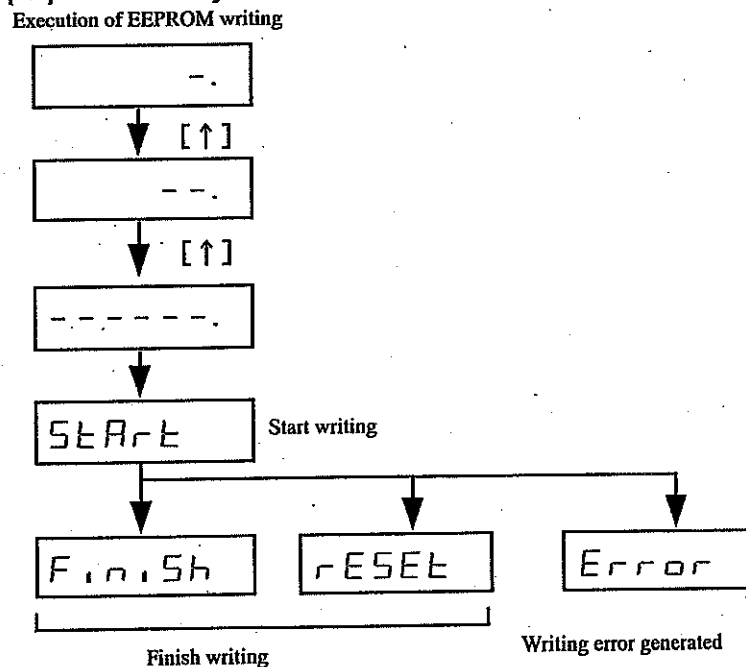

- (3) If the writing is finished, either of "F.in.Sh", "rESEt" or "Error" will be displayed.
- (4) In case of setting/changing parameter which becomes active after resetting the changed contents of the parameter, "rESEt" will be displayed at the time of writing finish.
Turn the power supply off once, and reset.
- (4) If [↑] is pressed continuously at the time of writing finish for EEPROM, a parameter can be written again.

Note1) If "Error" is displayed, it means that a writing error is generated at the time of writing into EEPROM.

If such writing error is generated, perform the writing again. If you still have the writing error even by repeating the same several times, the position driver may be broken. Contact with the store where you purchased.

Note2) Do not cut the power supply during writing into EEPROM.

Incorrect data may be written. In case of such situation, reset all parameters, and perform writing again after the enough check.

13-3-8 Automatic gain tuning

■ Executes the automatic gain tuning function.

Note1) For details of the automatic gain tuning function, refer to section 7-4 "Automatic Gain Tuning" (Page 21).

Especially, note that use this automatic gain tuning function after well understanding of applicability, cautions, etc. described in section 7-4.

Note2) On the automatic gain tuning mode, the motor will be operated 2 rotations to the CCW direction, and 2 rotations to the CW direction. Therefore, move the load to the position with no trouble even with 2 rotations of the motor.

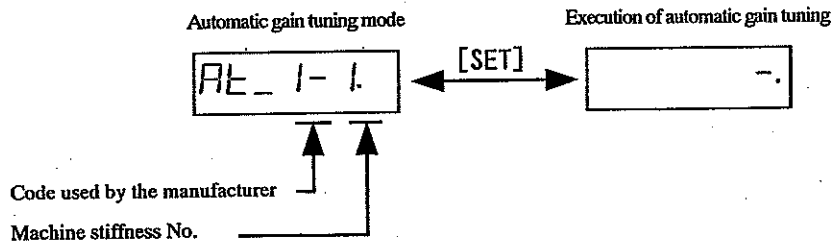

- By pressing [SET], automatic gain tuning mode display and execution display are switched,
 - On the automatic gain tuning mode display, it will be moved to the test operation mode if [MODE] is pressed.
 - To make the data set by the automatic gain tuning function active even after cutting the power supply, data must be written into EEPROM after finishing the automatic gain tuning.
- For data writing into EEPROM, refer to section 13-3-7 "EEPROM writing" (Page 71).

- (1) Set the machine stiffness.
By pressing [↑] and [↓] on the automatic gain tuning mode display, select the machine stiffness No.
For the machine stiffness No., refer to section 7-4.
- (2) Input servo-on signal.
- (3) Tuning operation will be started when "StArT" is displayed by continuously pressing [↑] on the tuning execution display.

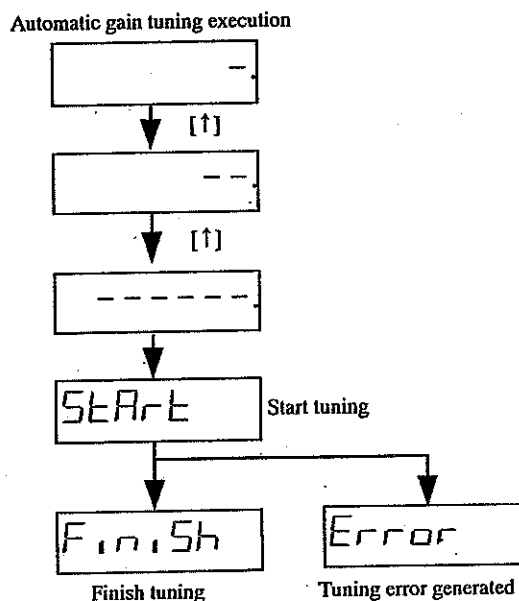

- (4) When the automatic gain tuning is finished, either of "F In 15h" or "Error" will be displayed.
- (5) If [↑] is pressed continuously at the time of the automatic gain tuning end, the tuning can be performed again.

Note3) Even when the automatic tuning mode is executed and finished normally, the machine operation may not be improved if it is not in the applicability described in section 7-4-2 (Gain before/after the automatic gain tuning will not be changed.). In such case, perform gain adjustment manually in accordance with section 9-2 "Gain adjustment" (Page 28).

13-3-9 Test operation

■ For jog operation, origin return operation, and step operation, they can be executed from the front panel, and the test operation can be performed.

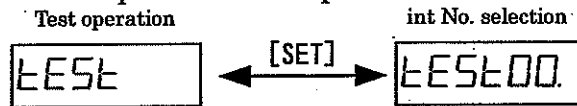

- By pressing [SET], test operation display and point No. selection display are switched.
- On the test operation display, it will moved to the monitor mode if [MODE] is pressed.

- (1) Switch to point No. selection display.
- (2) Set point No. of operation you would like to operate.
By pressing [↑] and [↓], switch the point No.
The relationship of point No. and operation command is as follows:

Point No.	Contents
0	Reset command
1	Move to step data 1.
2	Move to step data 2.
3	Move to step data 3.
4	Move to step data 4.
5	Move to step data 5.
.	.
.	.
.	.
27	Move to step data 27.
28	Move to step data 28.
29	High speed jog operation (- direction)
30	High speed jog operation (+ direction)
31	Origin return command

Note) Step operation cannot be operated without finishing the origin return.

- (3) By pressing [←], specified point No. operation will be executed.
In case of the jog operation, the motor will be operated during pressing [←].
During executing the command, "EESL - -" will be displayed.
- (4) If the operation is finished, it will be the point No. selection display, indicating the point No.
By pressing [←], operation command can be executed again.

14 Console operation

By connecting a console when turning the power supply on, the position driver can perform the operation with the following functions using the console: setting of various parameters, monitoring of the control state, referring to the alarm state, origin return, execution of jog operation and step operation, automatic gain tuning, etc.

14-1 Connection of console

- (1) When using a console, plug the connector securely into the connector SER1 after confirming that the power supply of MSS*XP is cut.
- (2) Check if the emergency stop switch of the console (Mushroom type switch) is not pushed into it. If the emergency stop switch is pushed into it, release the Emergency stop by turning the switch.
- (3) Turn the power supply of the position driver on after the connection.
On the console, a display will be appeared. Now, the console can be used.

Main menu display
Position Driver
MSS*XP Ver1.00
Panasonic (c)1997
[AUTO][EDIT][TEST]

Note1) As connector SER2 cannot be used, do not connect a console to the connector SER2.

Note2) In case that the console is removed after turning the power supply on, emergency stop input error will be generated. Also, note that the console cannot be used even by connecting the console after turning the power supply on.

14-2 Description of each key

Key	Key name	Key function
[F1] - [F5]	Function key	<input type="checkbox"/> Selects a menu.
[AUTO]	Automatic mode key	<input type="checkbox"/> Moves from the main menu state to the automatic mode.
[EDIT]	Edit mode key	<input type="checkbox"/> Moves from the main menu state to the edit mode.
[TEST]	Test mode key	<input type="checkbox"/> Moves from the main menu state to the test mode.
[POS]	Position edit mode key	<input type="checkbox"/> Moves from the edit mode menu state to the step data edit.
[SPD]	Speed edit mode key	<input type="checkbox"/> Moves from the edit mode menu state to the speed data edit.
[PARA]	Parameter edit mode key	<input type="checkbox"/> Moves from the edit mode menu state to the parameter (Offset data, NC data, servo parameter) edit state.
[ABS/INC]	Positioning mode setting key	<input type="checkbox"/> A key for specifying positioning mode at the step data edit. <input type="checkbox"/> ABS (Absolute positioning) and INC (Relative positioning) are switched every time the key is pressed.
[←H] [H→]	High speed jog key	<input type="checkbox"/> At the test mode Performs high speed jog operation. <input type="checkbox"/> At the step data edit Performs teaching for coordinate data input. (Only when finishing the origin return.)
[←L] [L→]	Low speed jog key	<input type="checkbox"/> At the test mode Performs low speed jog operation. <input type="checkbox"/> At the step data edit Performs teaching for coordinate data input. (Only when finishing the origin return.)
[ORG]	Origin return execution key	<input type="checkbox"/> Performs origin return operation at the test mode.
[STEP]	Step command key	<input type="checkbox"/> Performs step operation at the test mode.
[MOV]	Operation command key	<input type="checkbox"/> At the test mode A key for starting the operation actually after inputting the step No., when executing the step command with [STEP]. <input type="checkbox"/> At the step data edit Moves to the position of step data which is displayed. (Only when finishing the origin return).
[←]	Cursor key	<input type="checkbox"/> Within the edit mode Moves to the cursor position of the previous input. <input type="checkbox"/> At the value input Uses as back space (Deleting the value inputted at the last).
[→]	Cursor key	<input type="checkbox"/> Moves the cursor position of the next input within the edit mode.
[↑] [↓]	Cursor key	<input type="checkbox"/> Switches displayed No. within the edit mode.
[CLR]	Clear key	<input type="checkbox"/> When displaying the menu Returns to one upper menu after finishing various settings. <input type="checkbox"/> At the value input Cancels the value inputted.
[ENT]	Enter key	<input type="checkbox"/> At the value input Determines the value inputted. <input type="checkbox"/> Within the edit mode Moves to the cursor position of the next input.
[0] - [9]	Ten key	<input type="checkbox"/> Inputs a value.
[+/-]	Sign switching key	<input type="checkbox"/> Switches between +sign and -sing at the value input.

14-3 Outline of operation

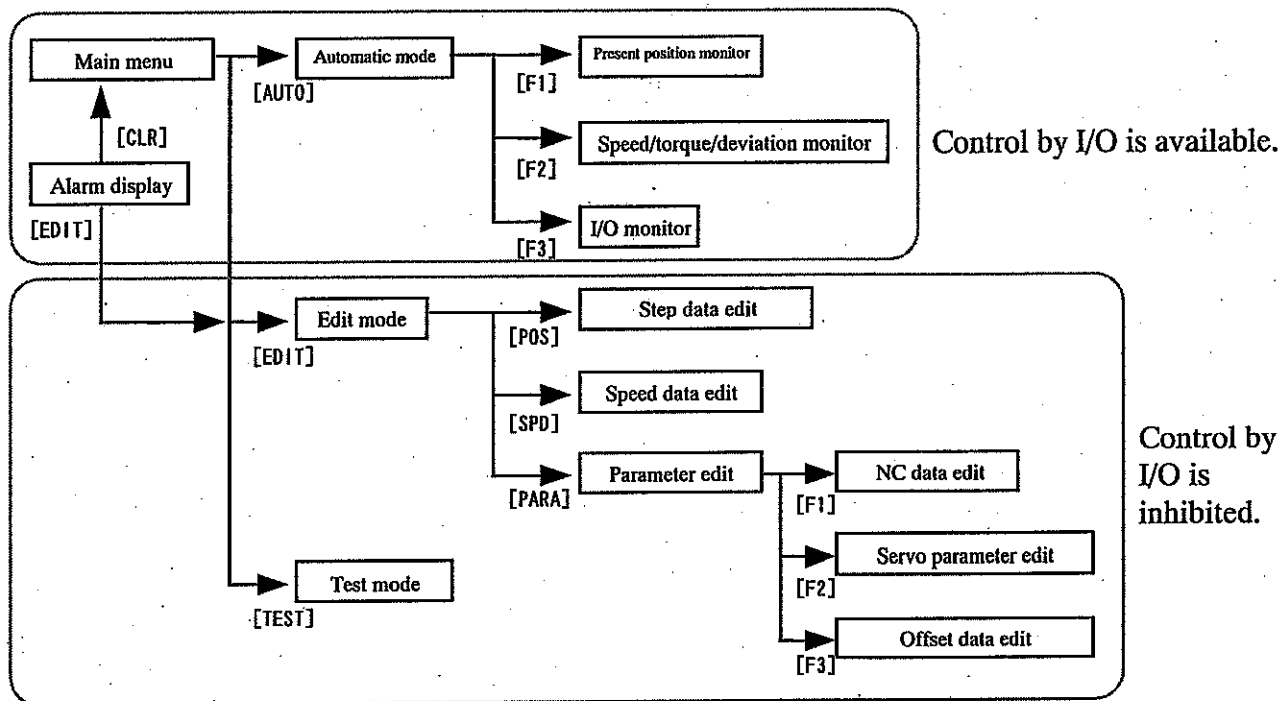

When returning to one upper level menu, press [CLR].

Mode	Item	Page	Function
Automatic mode	Present position monitor	77	<input type="checkbox"/> Displays the present position the motor.
	Speed/torque/deviation monitor	77	<input type="checkbox"/> Displays the present speed, torque and deviation monitor.
	I/O monitor	78	<input type="checkbox"/> Displays input/output signal state (ON/OFF).
Edit mode	Step data edit	80	<input type="checkbox"/> Sets and changes data for positioning.
	Speed data edit	83	<input type="checkbox"/> Sets and changes positioning speed, origin return speed, and jog speed.
	NC data edit	85	<input type="checkbox"/> Sets and changes acceleration data, operation direction setting, and input signal logic.
	Servo parameter edit	86	<input type="checkbox"/> Sets and changes servo parameters such as gain for the position driver.
	Offset data edit	88	<input type="checkbox"/> Sets and changes origin offset and software limit.
Test mode	Test mode	90	<input type="checkbox"/> Executes jog operation, origin return operation, step operation, etc. on the console.
Alarm display	Protection function (error) display	91	<input type="checkbox"/> Displays the error No. which is generated.

14-4 Automatic mode**(Main menu) → [AUTO]**

The present position monitor, the speed/torque/deviation monitor, or the I/O monitor is selected.

```

-AUTO (MONITOR)-
F1...POS
F2...SPD/TRQ/ERR
F3...I/O      [CLR]
  
```

- If [F1] is pressed, moves to the present position monitor.
- If [F2] is pressed, moves to the speed/torque/deviation monitor.
- If [F3] is pressed, moves to the I/O monitor.
- If [CLR] is pressed, returns to the main menu.

14-4-1 Present position monitor**(Main menu) → [AUTO] → [F1]**

Displays the present position of the motor.

```

-MON (POSITION)-
Position[pls]
          500000
          [CLR]
  
```

- If the origin return is not finished, displays "Origin Unfinished."
- If [CLR] is pressed, returns to the automatic mode menu.

14-4-2 Speed/torque/deviation monitor**(Main menu) → [AUTO] → [F2]**

Displays the rotation speed, the output torque, and the deviation counter of the motor.

```

-MON (SPD/TRQ/ERR)-
SPEED   :    0kpps
TORQUE  :    0%
ERR POS :    0 [CLR]
  
```

SPEED : Motor speed (kpps)
 TORQUE : Output torque (%)
 ERR POS : Deviation counter (pulse)

- If [CLR] is pressed, returns to the automatic mode menu.

14-4-3 I/O monitor

(Main menu) → [AUTO] → [F3]

Displays the input/output signal of the motor.

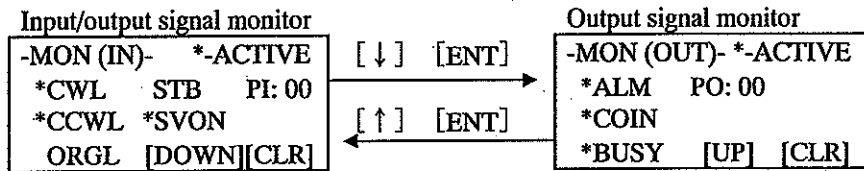

Note) By the option setting of NC parameter, positioning finish output (COIN) and decelerating output (DCLON) can be selected. On the output signal monitor display, it will be displayed with signal name which was set (COIN or DCLON).

- With [↑], switches from output signal monitor display to input signal monitor display.
- With [↓], switches from input signal monitor display to output signal monitor display.
- Every time [ENT] is pressed, switches between input signal monitor display and output signal monitor display.
- For the input signal monitor, signal with "*" mark indicates contact point close state. A value indicated with "PI: " displays the value inputted with the point assign input signal (5-bit) in decimal number.
- For the output signal monitor, signal with "*" mark indicates that the output transistor is turned on. A value indicated with "PO: " displays the value outputted with the present position output signal (5-bit) in decimal number.
- If [CLR] is pressed, returns to the automatic mode menu.

14-5 Edit mode

(Main menu) → [EDIT]

The step data edit, the speed data edit, or the parameter edit is selected.

Edit mode display

```
-EDIT-  
POS ... Position  
SPD ... Speed  
PARA ... Parameter [CLR]
```

- If [POS] is pressed, moves to the step data edit.
- If [SPD] is pressed, moves to the speed data edit.
- If [PARA] is pressed, moves to the parameter edit menu.
- If [CLR] is pressed, returns to the main menu.

14-5-1 Step data edit

(Main menu) → [EDIT] → [POS]

Sets and changes the step data to be necessary for executing positioning.

Note) After setting the data, perform EEPROM writing process when leaving the menu with [CLR]. Therefore, if the power supply is cut before the writing, note that the step data will not be memorized.

Step data inputted	Step data not inputted
-EDIT (POSITION)- No. 01 SPD: 01 MD: INC POS: 10000000 [U/D][MOV][ENT][CLR]	-EDIT (POSITION)- No. 01 SPD: - MD: --- POS: ----- [U/D][MOV][ENT][CLR]

No. : Step No. presently indicated (Setting change)
 SPD : Speed selection No.
 MD : Positioning mode (ABS/INC)
 POS : Positioning coordinate (Transfer amount)

For details of parameters, refer to section 10-2-1 "Step data" (Page 32).

- If [↑] is pressed, moves to one before the step No. and moves to the next step No. if [↓] is pressed.
- If [←] and [→] are pressed, moves the cursor to the position where input is available within the step data displayed.
- If [ENT] is pressed, moves the cursor to the position where the next input is available. The difference with [→] is that [→] moves the cursor only within the step data indicated. However, [END] moves it to the next step No.
- If [CLR] is pressed, returns to the edit mode menu. At the time, changed parameter will be written into EEPROM. If the power supply is cut before the writing, parameter after turning the power supply on will become inactive.

14-5-1-1 Input of speed selection No.

- (1) The cursor should be moved to the position of speed selection No. for the step data you would like to set. (If the step data is not inputted yet, display step data to which you would like to input new data.)
- (2) Using [0] - [9], input a value in the range of 1 to 10. If [←] is pressed, the value inputted at the last will be deleted. (Back space) After inputting the speed selection No., determine the value with [ENT]. Cancel the value inputted with [CLR], and display the original value.

14-5-1-2 Selection of positioning mode

- (1) The cursor should be moved to the position of positioning mode for the step data you would like to set.
- (2) If [ABS/INC] is pressed, positioning mode will be switched between ABS (Absolute positioning mode) and INC (Relative positioning mode).

Note) If "Only use relative transfer" is selected for the option setting of NC parameter, it will be inactive.

14-5-1-3 Input of positioning coordinate

- (1) The cursor should be moved to the position of positioning coordinate for the step data you would like to set.
- (2) To input the positioning data, there are two methods: directly inputting transfer amount with a value and specifying the position by teaching with jog key of the console.
(Teaching is available only when finishing the origin return.)

○ Value input

Using [0] - [9] and (+/-), input a value in the range of -1073741824 - 1073741823.

If [←] is pressed, the value inputted at the last will be deleted. (Back space) After inputting the transfer amount, determine the value with [ENT].

Cancel the value inputted with [CLR], and display the original value.

○ Teaching

If a jog key ([←H], [H→], [←L], or [L→]) is pressed, the motor will be operated, changing the coordinate value.

In case that high speed jog key ([←H], or [H→]) is pressed, the motor will be operated with the speed set with the jog speed (High speed), and it will be operated with the speed set with jog speed (Low speed) if ([←L], or [L→]) is pressed.

For the operation direction by the jog key, it will be changed depending on the parameter. For setting of the operation direction, refer to section 12-2 "Initial setting of NC parameter" (Page 41).

If the motor position is determined, determine the value with [ENT] key.

Cancel the value inputted with [CLR], and display the original value.

14-5-1-4 Execution of step operation

When finishing the origin return, it is possible to perform step operation to the step data displayed. (Only when finishing the origin return)

- (1) Display the step data you would like to execute the step operation.
- (2) If [MOV] is pressed, moves the motor to the step data position displayed. If [MOV] is pressed when not finishing the origin return, "Origin Unfinished" will be displayed, and the motor will not be operated.

○ Display during the operation

-EDIT (POSITION)- No. 05 SPD: 03 MD: ABS POS: 5352634 Moving to Point 05	← Motor position during the operation (It will be changed in real time.)
---	---

○ When finishing the step operation

-EDIT (POSITION)- No. 05 SPD: 03 MD: ABS POS: 10000000 [CLR]	← The present motor position
---	------------------------------

- (3) After finishing the step operation, if [CLR] is pressed, returns to the step data edit.

14-5-1-5 Deleting step data

It is possible to delete unnecessary step data.

- (1) Display the step data you would like to delete.
- (2) If [F1] is pressed, the following display will be appeared, asking if you delete the step data displayed.

-EDIT (POSITION)-	
No. 11 SPD: 05 MD: INC	
POS:	150000
DELETE OK?	[ENT: OK]

- (3) If [ENT] is pressed, the step data displayed will be deleted.

If other key is pressed, the deletion will be canceled.

- (4) As the data will be written into EEPROM when moving from the step data edit display to the edit menu by [CLR], the deleted contents will be invalid if the power supply of the position driver is cut before the writing.

14-5-2 Speed data edit

(Main menu) → [EDIT] → [SPD]

Sets and changes the reference speed, the origin return speed, the jog speed to be used for the step operation.

Note) After setting the data, perform writing processing into EEPROM when leaving the menu with [CLR]. Therefore, if the power supply is cut before the writing, note that the speed data will not be memorized.

Speed data inputted

-EDIT (SPEED)- 01/13	← Speed No.
ORIGIN SPEED	← Speed data
SPEED: 50kpps	← Setting speed
[UP][DOWN][ENT][CLR]	

Speed data not inputted

-EDIT (SPEED)- 01/13
ORIGIN SPEED
SPEED: --kpps
[UP][DOWN][ENT][CLR]

The speed data are listed in the following order.

Speed No.	Speed data	Function	Setting range
1	ORIGIN SPEED	Origin return speed	
2 - 11	STEP SPEED No. 01 - 10	Step operation reference speed 1-10	5 - 500 (kpps)
12	JOG SPEED (LOW)	Jog speed (low speed)	
13	JOG SPEED (HIGH)	Jog speed (high speed)	

For details of parameters, refer to section 10-2-2 "Speed data" (Page 32).

- If [↑] is pressed, moves to one before the speed No. and moves to the next speed No. if [↓] (or [ENT]) is pressed.
- If [CLR] is pressed, returns to the edit mode menu.

At the time, changed parameter will be written into EEPROM. If the power supply is cut before the writing, parameter after turning the power supply on again will be inactive.

14-5-2-1 Input of speed data

- (1) Display the speed data you would like to set.
- (2) Using [0] - [9], input a value in the range of 5 to 500.
If [←] is pressed, the value inputted at the last will be deleted. (Back space)
After inputting the speed, determine the value with [ENT].
Cancel the value inputted with [CLR], and display the original value.

14-5-2-2 Deleting speed data

It is possible to delete unnecessary speed data.

- (1) Display the speed data you would like to delete.
- (2) If [F1] is pressed, the following display will be appeared, asking if you delete the speed data displayed.

-EDIT (SPEED)- 05/13
STEP SPEED No. 04
SPEED: 50kpps
DELETE OK? [ENT: OK]

- (3) If [ENT] is pressed, the speed data indicated will be deleted.
If other key is pressed, the deletion will be canceled.
- (4) As the data will be written into EEPROM when moving from the speed data edit display to the edit menu by [CLR], the deleted contents will be invalid if the power supply of the position driver is cut before the writing.

14-5-3 Parameter edit menu

(Main menu) → [EDIT] → [PAPA]

NC parameter edit, servo parameter edit, or offset data edit is selected.

-PARAMETER-
F1...NC data
F2...Servo
F3...Off/Lmt [CLR]

- If [F1] is pressed, moves to the NC data edit.
- If [F2] is pressed, moves to the servo parameter edit.
- If [F3] is pressed, moves to the offset data edit.
- If [CLR] is pressed, returns to the edit mode menu.

14-5-4 NC data edit

(Main menu) → [EDIT] → [PAPA] → [F1]

Sets and changes the acceleration, the operation direction and the input logic.

Note) After setting the data, perform writing process into EEPROM when leaving the menu with [CLR]. Therefore, if the power supply is cut before the writing, note that the speed data will not be memorized.

-PARAMETER (NC)- 1/10 STEP Acc Time[msec] 100 [UP][DOWN][ENT][CLR]

NC data are listed in the following order.

Data No.	NC data	Function	Setting range
1	STEP Acc Time	Step operation acceleration/deceleration time	10 - 10000 (ms)
2	JOG Acc Time	Jog operation acceleration/deceleration time	10 - 10000 (ms)
3	ORG Acc Time	Origin return acceleration/deceleration time	10 - 10000 (ms)
4	JOG dir	Jog operation direction	0 - 1
5	ORG dir	Origin return direction	0 - 1
6	PLS dir	Pulse output direction setting	0 - 1
7	Teaching Step Pulse	Teaching transfer amount setting	0 - 32767
8	S-Curve rate	S-form acceleration/deceleration setting	0 - 10
9	INPUT Logical	Input logic setting	0 - 8063
10	Option	Option setting	0 - 123

For details of step operation acceleration/deceleration time, jog operation acceleration/deceleration time, origin return acceleration/deceleration time, input logic setting, and option setting, refer to section 10-2-4 "NC data" (Page 33). For details of S-form control setting, refer to section 12-7 "S-Form acceleration/deceleration function" (page 55). For settings of jog operation direction, origin return direction and pulse output direction, refer to section 12-2 "Initial setting of NC parameter" (Page 41).

- If [↑] is pressed, moves to one before the data No. and moves to the next data No. if [↓] (or [ENT]) is pressed.
- If [CLR] is pressed, returns to the edit mode menu.

At the time, changed parameter will be written into EEPROM. If the power supply is cut before the writing, parameter after turning the power supply on again will be inactive.

14-5-4-1 Input of NC data

- (1) Display NC data you would like to set.
- (2) Using [0] - [9], input data value.

If [←] is pressed, the value inputted at the last will be deleted. (Back space)

After inputting the data, determine the value with [ENT].

Cancel the value inputted with [CLR], and display the original value.

14-5-5 Servo parameter edit

(Main menu) → [EDIT] → [PAPA] → [F2]

Sets and changes servo parameters.

Note) After setting the data, perform writing process into EEPROM when leaving the menu with [CLR]. Therefore, if the power supply is cut before the writing, note that the speed data will not be memorized.

-PARAMETER (Srv)- 1/8 KP (0 - 1000) 50 [F1: ATune][ENT][CLR]

Servo parameters are listed in the following order.

Data No.	Parameter data	Function	Setting range
1	KP	Position loop gain (No. 20)	0 - 1000
2	KV	Speed loop gain (No. 03)	25 - 3500
3	KVi	Speed loop integration time constant (No. 04)	1 - 1000
4	Kff	Speed feed forward (No. 21)	0 - 100
5	Kffi	Feed forward filter time constant (No. 2B)	0 - 6400
6	Vf	Speed detection filter (o. 05)	0 - 4
7	Tfil	Torque filter time constant (No. 2A)	0 - 2500
8	P-ON delay	Startup delay time (No. 10)	0 - 600
9	Coin range	Positioning end range (No. 22) (Note)	0 - 32766

Note) Positioning finish range parameter will be displayed only when selecting the positioning finish output (COIN) under the option setting of NC parameter. If decelerating output (DCLON) is selected, this parameter will be displayed as "Not Use."

For details of each parameter, refer to section 10-3 "Details of Servo Parameters (User parameters)" (Page 35).

- If [↑] is pressed, moves to one before the data No. and moves to the next data No. if [↓] (or [ENT]) is pressed.
- If [CLR] is pressed, returns to the edit mode menu.

At the time, changed parameter will be written into EEPROM. If the power supply is cut before the writing, parameter after turning the power supply on again will be inactive.

14-5-5-1 Input of servo parameter

- (1) Display servo parameter you would like to set.
- (2) Using [0] - [9], input a data value.

If [←] is pressed, the value inputted at the last will be deleted. (Back space)

After inputting the parameter, determine the value with [ENT].

Cancel the value inputted with [CLR], and display the original value.

14-5-5-2 Automatic gain tuning function

The automatic gain tuning function can be executed on the console. For details of the automatic gain tuning function, refer to section 7-4 "Automatic Gain Tuning" (Page 21).

- (1) On the servo parameter setting display, press [F1].

```

-AUTO TUNING-
Stiffness (L: 1 - H: 9)
      5
[MOV: AT][CLR: Cancel]
```

- (2) Using [0] - [9], input the value of the machine stiffness (1 - 9). (The larger the value you set, the stiffer the tuning you can get.)
 If [←] is pressed, the value inputted at the last will be deleted. (Back space)
 After inputting the machine stiffness, the automatic gain tuning operation will be started with [MOV].
 Cancel the automatic gain tuning with [CLR].

- (3) During executing the automatic gain tuning, the display will be such as the following:

```

-AUTO TUNING-
Stiffness (L: 1 - H: 9)
      5
Auto Tuning Execute.
```

If alarm is generated during executing the automatic gain tuning, the following display will appear, and the gain will not be changed. If [CLR] is pressed, returns to the servo parameter setting display.

```

-AUTO TUNING-
Auto Tuning Error
                                     [CLR]
```

- (4) When finishing the automatic gain tuning normally, the setting gain will be displayed.

```

-AUTO TUNING-
KP: 70  KVi: 80
KV: 200  Kff: 0
[ENT: Wr][CLR: Cancel]
```

If [ENT] is pressed, servo parameter required for the automatic gain tuning will be changed, and the servo parameter will be returned to the value found before executing the automatic gain tuning if [CLR] is pressed.

- (5) After finishing the automatic gain tuning, the position driver state will be reset state. Execute the origin return command again to perform the step operation.

14-5-6 Offset data edit

(Main menu) → [EDIT] → [PARA] → [F3]

Sets and changes the origin offset and the software limit.

Note) After setting the data, perform writing process into EEPROM when leaving the menu with [CLR]. Therefore, if the power supply is cut before the writing, note that the speed data will not be memorized.

-PARAMETER (Off)- 1/3 Origin Offset 0 [UP][DOWN][ENT][CLR]

Offset data are listed in the following order.

Data No.	Offset data	Function	Setting range
1	Origin Offset	Origin offset	-1073741824 - 1073741823 (pulse)
2	Soft Limit (PLUS)	+ direction software limit	0 - 1073741823 (pulse)
3	Soft Limit (MINUS)	- direction software limit	-1073741824 - 0 (pulse)

For details and setting range of each parameter, refer to section 10-2-3 "Offset data" (Page 32).

- If [↑] is pressed, moves to one before the data No. and moves to the next data No. if [↓] (or [ENT]) is pressed.
- If [CLR] is pressed, returns to the edit mode menu.

At the time, changed parameter will be written into EEPROM. If the power supply is cut before the writing, parameter after turning the power supply on again will be inactive.

14-5-6-1 Data input

- (1) Display data you would like to set.
- (2) To input data, there are two methods: directly inputting amount with a value and specifying the position by teaching with a jog key of the console (Teaching is available only when finishing the origin return).

○ Value input

Using [0] - [9] and (+/-), input a data value.

If [←] is pressed, the value inputted at the last will be deleted (Back space).

After inputting the data, determine the value with [ENT].

Cancel the value inputted with [CLR], and display the original value.

○ Teaching

If a jog key ([←H], [H→], [←L], or [L→]) is pressed, the motor will be operated, changing the coordinate value.

In case that high speed jog key ([←H], or [H→]) is pressed, the motor will be operated with the speed set with the jog speed (High speed), and it will be operated with the speed set with the jog speed (Low speed) if low speed jog key ([←L], or [L→]) is pressed.

For the operation direction by the jog key, it will be changed depending on the parameter.

For setting of the operation direction, refer to section 12-2 "Initial setting of NC parameter"

(Page 41).

The value for the present position when setting the origin off set will be displayed normally at the position from the machine origin position, making it as the reference point.

If the motor position is determined, set the value with [ENT] key.

Cancel the value inputted with [CLR], and display the original value.

14-6 Test mode

(Main menu) → [TEST]

Performs a test for jog operation, origin return operation, and step operation.

```

-TEST-
Origin Unfinished.
[JOG][ORG][STP][CLR]

```

- "Origin Unfinished" is displayed if the origin return is not finished, displaying the present motor position (pulse unit) when finishing the origin return.
- If [CLR] is pressed, returns to the main menu.

14-6-1 Jog operation

If a jog key ([←H], [H→], [←L], or [L→]) is pressed, the jog operation will be operated. (The jog operation is executable even when not finishing the origin return.)

In case that high speed jog key ([←H], or [H→]) is pressed, the motor will be operated with the speed set with the jog speed (High speed), and it will be operated with the speed set with jog speed (Low speed) if ([←L], or [L→]) is pressed.

For the operation direction by the jog key, it will be changed depending on the parameter. For setting of the operation direction, refer to section 12-2 "Initial setting of NC parameter" (Page 41).

```

-TEST-
Jog Speed : High
Origin Unfinished.
[JOG][ORG][STP][CLR]

```

- On the display, it is displayed that high speed jog key (High) or low speed jog key (Low) is pressed, and the motor present position (Pulse unit) will be displayed when finishing the origin return.

14-6-2 Origin return operation

If [ORG] is pressed, the origin return operation will be started.

```

-TEST-
Origin Proceeding
[JOG][ORG][STP][CLR]

```

- If the origin return operation is finished, the present position will be defined, and the motor present position (Pulse unit) will be displayed.

14-6-3 Step operation

If [STEP] is pressed, the step operation will be operated.

Note) If the origin return is not finished, [STEP] will be ignored.

```

-TEST-
STEP No.>
[31]           0
              [MOV][CLR]
  
```

- Displays state of the present position and the present position output (within the []).
- With [CLR], returns to the test mode menu.

(1) Using [0] - [9], input step No. in the range of 1 to 28.

If [←] is pressed, the value inputted at the last will be deleted. (Back space)

After inputting the step No., operation will be started with [MOV].

Cancel the value inputted with [CLR], and finish the step No. input.

(2) During the step operation, a display such as the following will appear, changing the present position.

```

-TEST-
STEP No. > 5
[31]       233423
Moving to Point 05
  
```

(3) If the step operation is finished, the present position output will be changed.

14-7 Alarm display

If servo alarm is generated at the automatic mode or the test mode, it will automatically moved to the alarm display.

Alarm No. and alarm name will be displayed.

```

-ALARM-
ALARM No. 52
Spd/Acc Undef. Err
              [EDIT][CLR]
  
```

- Execute alarm clear command with [CLR], and move to the main menu after clearing the alarm.
- Even during the alarm generated, parameter can be set or changed with [EDIT]. However, if under voltage protection is working, it will be invalid after turning the power supply off even with setting or change of the parameter.

14-8 Cautions when connecting a console

- In case that the position driver is controlled from I/O under the condition of connecting the console, timing chart shown in section 12-6 "Interface timing" (Page 48) will not be applicable. Especially, in case that MSS*XP is controlled by the sequencer, executing the console monitoring function, note that the response may be extremely delayed.
- Even if the console is connected after turning of the power supply on for MSS*XP, the console will not be recognized. When using the console, be sure to connect the console before turning the power supply on, and then turn the power supply on.
- Do not pull the connector section of the console. If the console is removed after turning the power supply on, Emergency stop error (53) will be generated, and the motor will be stopped by activating the protection function of the position driver.
- If undervoltage protection is working to the position driver, note that the changed parameter will not be written into EEPROM.

15-2 Function specification

Item	Contents
Program point number	28 points
Position command input signal Present position output signal	5-bit
Max. position command (pulse)	31-bit with symbol (-1073741824 - 1073741823)
Position command status	ABS/INC (Absolute position/relative position) can be specified for each step.
Speed range	Max. 500kpps (3000r/min.)
Speed setting	5kpps - 500 kpps (6r/min./kpps) Setting in 1 kpps unit. The following contents can be set respectively. Jog speed (high speed/low speed) Origin return speed Step speed (Reference speed 10 steps)
Acceleration/deceleration setting	Setting by linear acceleration/deceleration time up to 500kpps. 10ms. - 2s. Acceleration/deceleration resolution 10ms. Unit S-form control is available (At the step operation and the jog operation acceleration)
Origin return function	Origin sensor + Z-phase
Memory status	EEPROM backup