



MINIDRIVE DMD02.1 / MMD - with position interface

User's Manual

DOK-MINIDR-DMD/MMD*POS-AW02-EN-P

Title MINIDRIVE

Type of documentation Users Manual

Document code DOK-MINIDR-DMD/MMD_EN

Internal file reference 120-1400-B303-02/EN

Editing sequence

Document designation of previous editions	Date	Comments
DOK-MINIDR-DMD/MMD*ANA-ANW1-EN-P	Nov98	First Release
DOK-MINIDR-DMD/MMD*ANA-AW02-EN-P	Mar99	Sec. Release

The purpose of this document

It serves

- to assist in the familiarization with MMD servo motors
- in mechanically integrating the motor into the machine
- in electrically integrating the motor into the machine
- to assist in connecting the motor
- in determining the motor cables and connectors required

Copyright © INDRAMAT GmbH, 1999

Copying this document and giving it to others and the use or communication of the contents thereof without express authority, are forbidden. Offenders are liable for the payment of damages. All rights are reserved in the event of the grant of a patent or the registration of a utility model or design (DIN 34-1).

Published by INDRAMAT GmbH • Bgm.-Dr.-Nebel-Str. 2 • D-97816 Lohr a. Main
Phone 09352/40-0 • Tx 689421 • Fax 09352/40-4293
Dept. BAG (KF,DW,BA)

Validity All rights are reserved with respect to the contents of this documentation and the availability of the product.

CONTENTS

1	Applicability	1-1
1.1	Introduction	1-1
1.1.1.	After opening the package.....	1-1
1.1.2.	Confirmation of the applicable motor.....	1-1
1.1.3.	Type of driver	1-2
1.1.4.	Type of motor.....	1-3
1.1.5.	Accessories	1-4
2	Safety warnings	2-1
2.1	Precautions in handling safely	2-1
2.1.1.	General comments	2-2
2.1.2.	Storage.....	2-3
2.1.3.	Transportation.....	2-3
2.1.4.	Installation	2-4
2.1.5.	Wiring.....	2-4
2.1.6.	Control and Operation.....	2-4
2.1.7.	Maintenance and Check	2-6
2.1.8.	Disposal	2-6
2.1.9.	Others	2-6
2.1.10.	Appearance and Each Part Name	2-7
2.2	Notices in use	2-8
2.2.1.	Cautions for safety.....	2-8
2.2.2.	In order to use the product properly.....	2-9
2.2.3.	Cautions for installation and storing.....	2-10
2.2.4.	Installation place	2-12
3	Wiring	3-1
3.1	Cautions in wiring.....	3-1
3.1.1.	Wiring material to be used and maximum length of wiring.....	3-1
3.1.2.	Wiring to terminal block	3-1
3.1.3.	Wiring to connector I/F	3-4
3.1.4.	Wiring to connector SIG	3-6
3.1.5.	Wiring to connector SER	3-8
3.2	Wiring device selection	3-8

4	Function	4-1
4.1	Details of input/output signals (Connector I/F).....	4-1
4.2	Input/output circuit configuration	4-5
4.2.1.	Control input.....	4-5
4.2.2.	Control output	4-6
4.2.3.	Analog signal output (Monitor output)	4-7
4.3	Dynamic Brake.....	4-8
4.4	Automatic gain tuning	4-9
4.4.1.	Summary	4-9
4.4.2.	Applicability	4-9
4.4.3.	Notices	4-9
4.4.4.	Automatic gain tuning operation	4-10
4.4.5.	How to operate.....	4-10
4.5	Protective function	4-11
4.5.1.	Summary	4-11
4.5.2.	Details of protective function.....	4-12
5	Operation	5-1
5.1	Inspection before operation	5-1
5.2	Trial operation	5-1
6	Adjustment	6-1
6.1	Confirmation of rotary encoder voltage.....	6-1
6.2	Gain adjustment.....	6-1
6.2.1.	Gain adjustment principle	6-2
6.2.2.	Notices in gain adjustment.....	6-2
7	Parameter	7-1
7.1	Summary of parameter.....	7-1
7.1.1.	NC parameter	7-1
7.1.2.	Servo parameters	7-2
7.2	Details of NC parameters	7-5
7.2.1.	Step data.....	7-5
7.2.2.	Velocity data	7-5
7.2.3.	Offset data	7-6
7.2.4.	NC data.....	7-7
7.3	Details of Servo Parameters (User parameters)	7-11
8	Communication function	8-1
	Construction units and software	8-1
8.1.1.	Construction units	8-1
8.1.2.	Software for communication control (MINITERM)	8-2

9	Operation	9-1
9.1	Summary of Functions	9-1
9.2	Initial setting of NC parameter	9-2
9.3	Position driver state transition	9-3
9.4	Sequence at power-ON	9-4
	9.4.1. Electromagnetic brake release timing	9-5
9.5	Action specifications	9-5
	9.5.1. Step command.....	9-5
	9.5.2. Jog command	9-6
	9.5.3. Origin return command	9-6
	9.5.4. Reset command.....	9-6
	9.5.5. Emergency stop input	9-7
9.6	Interface timing	9-9
	9.6.1. Step command, origin return command	9-9
	9.6.2. Jog command	9-11
	9.6.3. Reset command	9-12
9.7	S-shape acceleration/deceleration function	9-14
9.8	Special function.....	9-16
	9.8.1. Origin return offset function	9-16
	9.8.2. Positioning method selection	9-16
	9.8.3. Control state selection at servo-off	9-17
	9.8.4. Torque output selection at limit signal input.....	9-18
10	Key operation on the front panel	10-1
10.1	Description of each key.....	10-1
10.2	Summary of operation.....	10-1
10.3	Details of operation	10-4
	10.3.1. Monitor mode	10-4
	10.3.1.1. Position deviation monitor	10-4
	10.3.1.2. Velocity monitor.....	10-5
	10.3.1.3. Torque monitor.....	10-5
	10.3.1.4. ID No. display.....	10-6
	10.3.1.5. Present position monitor	10-6
	10.3.1.6. Input/output signal monitor.....	10-7
	10.3.1.7. Error No. display	10-8
	10.3.1.8. Parameter display used by the manufacturer	10-8
	10.3.2. Step data edit.....	10-8
	10.3.2.1. Input of positioning coordinate	10-9
	10.3.2.2. Input of velocity selection No.	10-9
	10.3.2.3. Selection of positioning mode	10-10
	10.3.3. Velocity data edit.....	10-10
	10.3.4. NC data edit.....	10-12

10.3.5. Offset data edit	10-13
10.3.5.1. Input of offset coordinate	10-14
10.3.6. Servo parameter edit	10-14
10.3.7. EEPROM write-in	10-16
10.3.8. Automatic gain tuning	10-17
10.3.9. Test-run	10-20
11 Specification	11-1
11.1 General specification	11-1
11.2 Functional specification	11-3
11.3 Regenerative energy	11-3
11.4 Dimensions	11-4
11.3.1. DMD02.1-W012 and DMD02.1-W022	11-4
11.3.2. DMD02.1-W042	11-5
11.3.3. DMD02.1-W082	11-6
12 Typecode	12-1
12.1 Type Code – Drive controller	12-1
12.2 Type code – Motor	12-2
13 MMD - Motor	13-1
13.1 Mechanical integration into the machine	13-1
13.1.1. Conditions of use	13-1
13.2 Technical data	13-4
13.3 Characteristics	13-5
13.3.1. MMD012A – 100W	13-5
13.3.2. MMD022A – 200W	13-6
13.3.3. MMD042A – 400W	13-7
13.3.4. MMD082A – 750W	13-8
13.3.5. Instantaneous operation area	13-8
13.4 Dimensional data	13-9

1 Applicability

This specification relates to a position driver section of AC servo system which consists of an AC servo motor and a position driver that drives the same motor delivered by Indramat.

1.1 Introduction

1.1.1. After opening the package

Firstly, check the following points:

- (1) If the product is the right one you ordered.
- (2) If there is no damage in the product after the shipment etc.

If you find any problem, please contact with the dealer or the distributor where you purchased.

1.1.2. Confirmation of the applicable motor.

Position drivers are designed to be used with AC servo motors by Indramat. Refer to the following table and confirm that the applicable AC servo motor output for each position driver is matching with the series name, the voltage specifications, and the encoder specifications for the applicable AC servo motor.

Model-Nr.	Motor				
Driver	Model-Nr.	Output	Voltage-specification	Speed (rpm)	Pulse
DMD02.1-W0 12	MMD012A1*	100W	230V	3000 rpm	2500 Pulse/R
DMD02.1-W0 22	MMD022A1*	200W	230V		
DMD02.1-W0 42	MMD042A1*	400W	230V		
DMD02.1-W0 82	MMD082A1*	750W	230V		

1.1.3. Type of driver

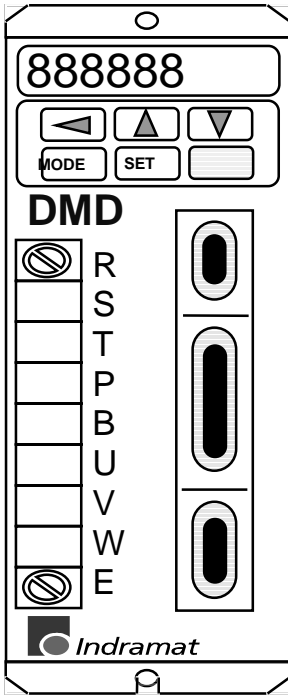

100 Watt
200 Watt

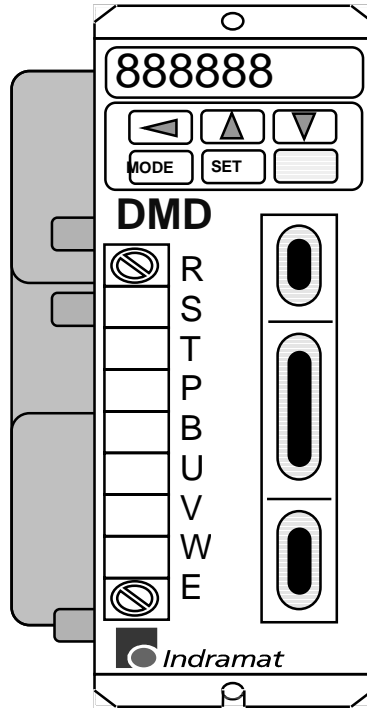

400 Watt
750 Watt

1.1.4. Type of motor

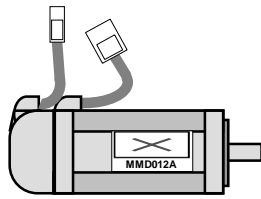

MMD012A-030-EG_-KN

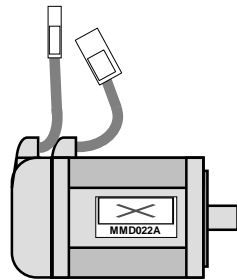

MMD022A-030-EG_-KN

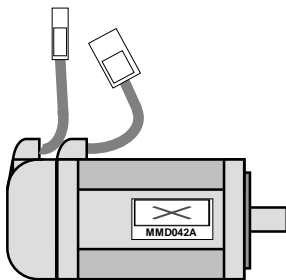

MMD042A-030-EG_-KN

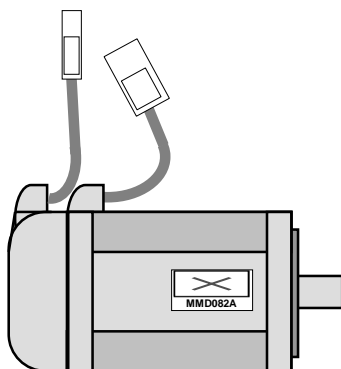

MMD082A-030-EG_-KN

Type

without brake:

MMD012A-030-EG0-KN
 MMD022A-030-EG0-KN
 MMD042A-030-EG0-KN
 MMD082A-030-EG0-KN

with brake:

MMD012A-030-EG1-KN
 MMD022A-030-EG1-KN
 MMD042A-030-EG1-KN
 MMD082A-030-EG1-KN

1.1.5. Accessories

Accessory set for motor: SUP-E01-MMD

For connecting the motor you can use the accessory set SUP-E01-MMD.

Contents:

- Plug 15pol. (Encoder)
- Plug 4pol. (Motor connection)
- Plug 2pol. (Brake)

Accessory set for Driver: SUP-E01-DMD

For connecting encoder and I/O-signals use the accessory set SUP-E01-DMD.

Contents:

- Plug 20pol. with case
- Plug 36pol. with case

2 Safety warnings

2.1 Precautions in handling safely

Before installation, operation, maintenance and checking of the position driver, be sure to read this instruction manual thoroughly.

Use this product after fully understanding the knowledge of this equipment, the safety information, and the cautions.

In this instruction manual, these cautions for the safe operation are treated in two levels as "WARNING" and "CAUTION."



However, as all items described even in will lead to serious results depending on the conditions, be sure to strictly follow the important contents of both WARNING and CAUTION.

2.1.1. General comments



Warning

Be sure to keep the following to prevent possible electric shock and injury.

1. Do not touch inside of the position driver.
Failure to observe this instruction could result in electric shock.
2. Provide the earth terminal for the position driver and the motor without fail.
Failure to observe this instruction could result in electric shock.
3. When transporting, wiring, maintenance, and checking the product, shut off the main power supply and make sure that LED display on the panel is completely turned off.
Failure to observe this instruction could result in electric shock.
4. Do not damage the cable, give excessive stress on it, put an heavy matter on it, nor pinch it.
Failure to observe this instruction could result in electric shock.
5. Do not touch any part of the rotating section of the motor during the operation.
Failure to observe this instruction could result in injured.



Caution

1. Use the motor and the position driver in the designated combination.
Failure to observe this instruction could result in fire.
2. Do not subject the driver to water splash, nor use it in corrosive atmosphere, atmosphere of inflammable gas and near combustibile materials.
Failure to observe this instruction could result in fire.
3. Do not touch the position driver, the motor, and the peripheral equipment as the temperature around them is very high.
Failure to observe this instruction could result in burn.



Caution

4. During the power-ON state, or for a while after shutting off the power supply, heat-sink and regenerative resistor of the position driver , and the motor becomes hot. Do not touch them.
Failure to observe this instruction could result in burn.

2.1.2. Storage



Must Not

Do not store the product where it is subjected to rain or water splash, or where hazardous gas or liquid is found..



Must

1. Store the product where it isn't exposed to the direct sunlight and within the designated temperature/humidity range.
2. If the product had been stored for quite along time, contact to the distributor before using the driver.

2.1.3. Transportation



Caution

1. When carrying the product, do not hold the cable or the motor shaft.
Failure to observe this instruction could result in injury.



MUST

1. Do not overstock the product to avoid collapsing. Observe the instructions.

2.1.4. Installation



1. Do not step on the product nor place a heavy material on it.
Failure to observe this instruction could result in injury.
2. Do not block the intake/outlet port, and prevent foreign materials from entering them.
Failure to observe this instruction could result in fire.
3. Be sure to follow the designated direction for the installation.
Failure to observe this instruction could result in fire.
4. Keep the specified distance between the body and the inside of the control board or other equipment.
Failure to observe this instruction could result in fire.
5. Do not give a strong shock.
Failure to observe this instruction could result in injury due to an abnormal action.
6. Conduct the appropriate installation, matching with the output or the main unit weight.
Failure to observe this instruction could result in injury.
7. Install to noncombustible materials such as metal etc.
Failure to observe this instruction could result in fire.

2.1.5. Wiring



1. Perform wiring correctly and securely.
Failure to observe this instruction could result in electric shock, injury and fire.

2.1.6. Control and Operation



1. The motor is not equipped with protective equipment. Install overcurrent protection device, earth leakage breaker, thermal protector and emergency stop apparatus.
Failure to observe this instruction could result in electric shock, injury and fire.

**Caution**

2. Confirm if the power supply specifications are correct.
Failure to observe this instruction could result in electric shock, injury and fire.
3. Conduct the trial run by fixing the motor, and confirming the action after separating from the machine system.
Failure to observe this instruction could result in injury.
4. Since the retaining brake is used only for position retention of the machine, do not use it as a stopping device to obtain the machine safety.
Failure to observe this instruction could result in injury.
5. Do not conduct an extreme adjusting change which will make the action unstable.
Failure to observe this instruction could result in injury.
6. When alarm condition occurs, try to eliminate the cause and restart after the alarm reset, obtaining the safety.
Failure to observe this instruction could result in injury.
7. Since there is a possibility of a sudden restart after resuming from instantaneous power failure, do not get close to the machine.
(Design the machine to secure the safety against personnel even after the restart.)
Failure to observe this instruction could result in injury.

**Must Not**

1. As the brake installed in the motor is for the retention, do not use as the normal control braking.

**Must**

1. Install an emergency stop circuit externally to stop operation by shutting off the main power supply.

2.1.7. Maintenance and Check



Caution

1. Capacitor for the power supply line will decrease its capacity due to the deterioration. To prevent the secondary accident, it is recommend to replace them approximately every 5 years. Failure to observe this instruction could result in failure.

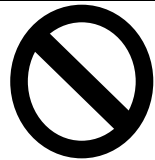

Must Not

1. Overhaul by customer is prohibited.

2.1.8. Disposal



Caution

1. When disposing the position driver, dispose it as industrial waste.

2.1.9. Others

General Cautions

Since all figures in this operation manual are described without a case cover or blocking objects for the safety to explain in detail, return them to the designated place in operating the product, and operate it in accordance with the instruction manual.

(Meanings of other signs used in this instruction manual)



Must Not



Must

2.1.10. Appearance and Each Part Name

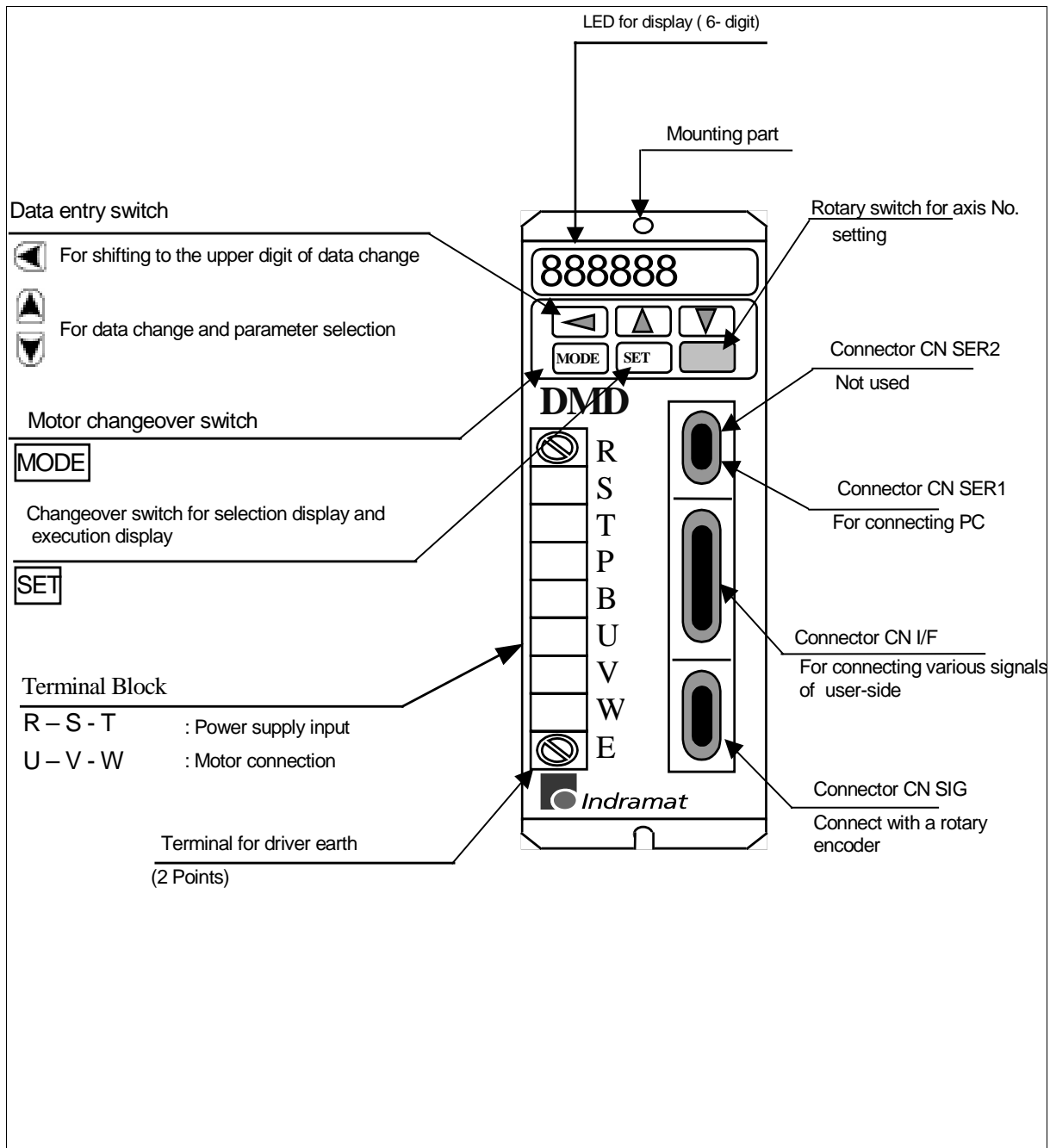

2.2 Notices in use

Be sure to observe the following instructions to prevent electric shock and injuries.

2.2.1. Cautions for safety

- (1) Never touch inside of the position driver during its running because of high-voltage live circuit . If the overhaul or repair is necessary, request it to the distributor.
- (2) After turning off the main power, the inside of the circuit is still charged with high voltage for a while. Shut the power supply input completely outside the position driver and wait for 5 minutes or longer, to touch inside of the position driver and terminals on the terminal block.
- (3) Do not touch the position driver, the motor and the peripheral equipment during the power-ON state as temperature of these units becomes high.
Especially when using the optional regenerative resistor, do not place combustible materials near the resistor, as it becomes high temperature.
- (4) While the power supply is ON, keep enough distance from the motor and the machine driven by it in case of the malfunction.
- (5) Never touch the rotating part of the motor while it is running.
- (6) Do not touch the heat-sink, regenerative resistor of the position driver and the motor for a while even after shutting off the power, since they are hot.
- (7) When an alarm state occurs, remove the cause to assure the safety and restart after the alarm reset.
- (8) As there may be sudden restart after resuming from instantaneous power shutoff, do not get close to the machine.
- (9) If the driver will not be in use for a long time, be sure to turn off the power supply.
- (10) Capacitor of the power supply rectification circuit will lower the capacity due to the aging. It is recommended to replace them every 5 years to prevent the secondary accident due to the failures.
- (11) For wiring, use a breaker according to section 3.1.2., „Wiring to terminal block”.

Install an Emergency Stop Circuit to stop an operation immediately and to shutoff the main power

Setting and installation of the equipment should be done securely in consideration of an unexpected earthquake.

After an earthquake, be sure to check on the safety.

2.2.2. In order to use the product properly

Since an incorrect use of the driver may lead to an abnormal operation, or may damage the position driver in the worst case, carefully read the following cautions to operate properly.



Read this manual thoroughly for the proper operation. Always keep this manual beside the machine and read it again when you have questions.

- (1) Do not apply higher voltage than the permissible range to the power supply input terminals (R,S,T).
- (2) Using the external brake polarity is equal.
- (3) Do not connect the power supply to other terminals than the power supply input terminals (R,S,T) in any case. For wiring, refer to section 3.1.2. "Wiring to the terminal block".
- (4) The input power side is capacitor input type. At turning on the power supply, high charge current will run and there may be a great voltage drop because of the power supply impedance. It is recommend to use an independent power supply for the position driver.
- (5) For the power supply capacity, refer to section 3.2 "Wiring device selection".
- (6) Install the product at ambient temperature of 0°C - 50°C. If the temperature exceeds this range, it may cause malfunction or failure.
- (7) Do not conduct dielectric test or megger test.
(When conducting these tests for an external circuit, pull out all front terminals of the position driver and the connector so that no test voltage may be applied to the position driver.)
- (8) Do not run the driver and the motor with overload exceeding its capacity (such as continuous overcurrent operation).
- (9) After shutting off the power supply, allow interval of approx. 6 to 11 seconds before turning it on again. If this interval is short, it may not start up normally because its internal circuit cannot be initialized.
- (10) If a leakage current breaker is used, use the one especially made for "Inverter" with high-frequency ability.
- (11) Use the motor and the position driver in the designated combination.
- (12) After checking that the input voltage is in accordance with the position driver specifications, turn on the power supply to operate. If higher voltage than the rating is applied, it may cause fire or smoke, and may result in abnormal operation and burning of the motor.
- (13) Conduct the trial run after fixing the motor and confirming that the machine system is separated, then install the motor to the machine.
- (14) Since the retaining brake is used for position retention of the machine, do not use it as a stopping device to obtain the machine safety.
- (15) Do not conduct an extreme gain adjustment change, since it may cause unstable operation.

2.2.3. Cautions for installation and storing

For transportation, treat the position driver carefully to prevent its breakage. Do not grasp the cable and the motor shaft while carrying it.

Do not apply excessive force to the front panel and side plates of the position driver.

- (1) For the se  motor, high frequency switching current is applied and leak current runs under the situation. To release the leak current, be sure to connect the driver earth terminal () and the motor earth terminal, and then earth at one point. Also, earth the machine main unit. Class 3 Earthing (Under 100Ω , 1.6mm or larger) is recommended for preventing electric shock and malfunction. In case of using the earth leakage breaker, use the one „for inverter“ provided with high-frequency ability.
- (2) This position driver is designed for vertical installation. Be sure to keep the mounting direction.
- (3) Install the driver to noncombustible material such as metal.
- (4) Install the driver appropriately, matching with the output and the main unit weight.
- (5) This position driver is not water-proof structure. Do not use the driver outdoor.
- (6) Do not step on the driver or put a heavy matter on it.
- (7) Do not block the intake/outlet port, and prevent foreign material from entering in.
- (8) Conduct the wiring correctly and securely. Incorrect and insecure wiring could cause abnormal operation and burning for the motor.
- (9) Do not damage the cable, apply excessive stress to it nor place a heavy matter on it.
- (10) Never store, install and use the driver where vibration and shock of 4.9m/s^2 or more are applied; much metal powder and dust exist; the driver is subjected to water, oil and grinding fluid splash; combustible material is nearby; and corrosive gases and inflammable gases are generated. Also, do not use the driver continuously at the resonance point.
- (11) Do not apply a strong impact shock.

- (12) Pay attention to heat radiation. Heat generated at the position driver control part and heat by the motor current with the motor operation are added. If the position driver is used in an enclosed control box, temperature in the control box may be increased abnormally. In case of operating with the driver installed in the control box, pay attention to the cooling to lower the position driver's ambient temperature under the maximum ambient temperature. Try to keep specified distance between the main unit and the inside of the control

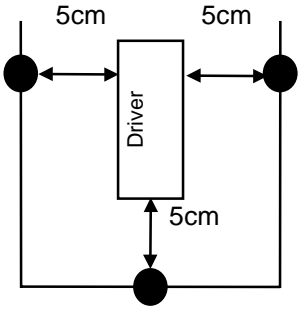
<p>Ambient temperature of the position driver</p> <p>Life time of the position driver is greatly influenced by the ambient temperature.</p> <p>Check that ambient temperature of 5cm around the position driver does not exceed the maximum ambient temperature.</p> <p style="text-align: center;">Ambient temperature: 0°C - 50°C</p>	
--	---

board or other equipment.

- (13) Do not install near heat-generating elements such as heaters and large-size wire wound resistor. When such installation is unavoidable in terms of mounting and installing conditions, provide a thermal shield etc. between the position driver and the heat-generating elements, so as not to be affected by such elements.
- (14) Do not store the driver where the driver is subjected to rain drops or water splash or harmful gas and liquid are found.
- (15) Store the driver where it isn't exposed to the direct sunlight and within the designated temperature/humidity range.
- (16) If the driver has not been used for a quite a long, contact to a distributor.
- (17) Do not overstock the driver to avoid the load shifting.

2.2.4. Installation place

- (1) This driver is designed for vertical installation.
For the installation, fit it vertically and have sufficient space for the ventilation around it.

When installing, firmly fit the position driver with screws and bolts without applying stress such as bending and twisting to the position driver main unit.

For mounting, use screws and bolts of M4 or M5 size.

For the mounting pitch, refer to the dimensional outline drawing.

- (2) Do not install the driver where high temperature and high humidity are expected, or in the atmosphere with much dust, dirt, iron powder and chip.
- (3) Install the driver where ambient temperature is 0°C - 50°C.
- (4) Avoid places exposed to direct sunlight.
- (5) Install the driver where no corrosive gases exist and grinding fluid does not splash.
- (6) This driver is not dust proof.
- (7) Do not use the driver outdoor. Install the driver where no vibration exists.
Do not use the driver continuously at resonance point.

3 Wiring

3.1 Cautions in wiring

3.1.1. Wiring material to be used and maximum length of wiring

Name	Symbol	Maximum Length of Wiring	Electric Wire to be Used	
			DMD02.1-W012 DMD02.1-W022	DMD02.1-W042 DMD02.1-W082
Power Supply	R, S, T	–	HVSF 1.25mm ²	HVSF 2mm ²
External Brake		20m	HVSF 0.5mm ²	HVSF 0.5mm ²
Motor Connection	U, V, W, E	20m	HVSF 1.25mm ²	HVSF 2mm ²
Earth Cable		1m	2mm ² or more	2mm ² or more
Encoder Connection	CN SIG	20m	Collective Shield Twist Pair Line Core line Min. 0.18mm ² or more	
Input/Output Connection	CN I/F	3m		

3.1.2. Wiring to terminal block

Fundamental

The driver is designed for single and triple phase connection.

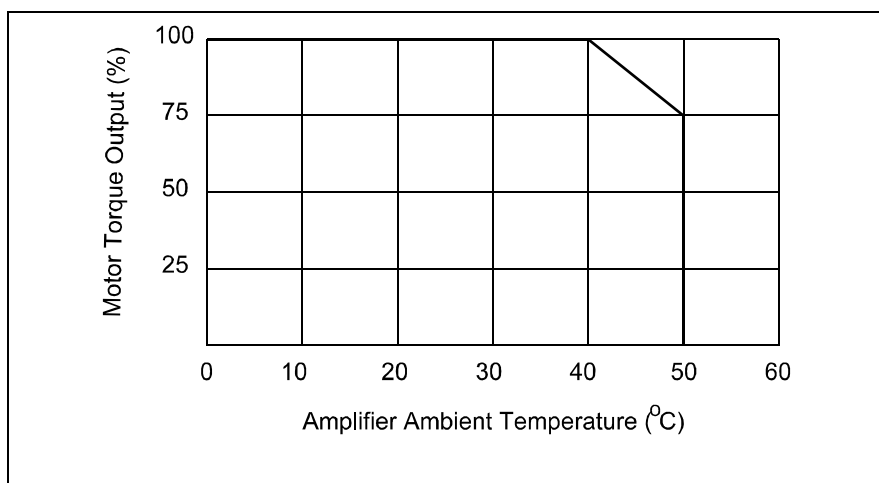

The 200 VAC Models May Be Operated From a Single Phase Supply With the Following Derating:

- 100 Watt Model: No derating required
- 200-750 Watt Models: Derate torque output by 2.5% per °C above 40°C (see chart).



- (1) The terminal block cover is fixed by screws. Unscrew it to open and make wiring to the terminal block.
- (2) Wire securely according to Fig 3-1 "Wiring to terminal block".
- (3) With regard to devices for wiring and electric wires to be used, etc., refer to 3-2.
- (4) For power supply voltage, apply a voltage indicated on the name plate.
- (5) Do not make reverse connection of the power input terminals (R,S,T) and the motor output terminals (U,V,W).
- (6) Do not ground or short-circuit the motor output terminals (U,V,W) mutually.

Note) Earth terminal () has a structure that it will be connected to the frame separately from the terminal block. Incorrect connection of the earth cable to the terminal block may damage the driver.

- (7) Usually, do not connect anything to terminals (P,B). Also, do not touch terminals (P,B) as high-voltage is applied when turning on the power supply.
If absorbing capacity of regenerative energy is insufficient in some cases, consult with a distributor.
- (8) Unlike an induction motor, AC servo motor does not make reverse rotation by changing the 3-phase. Wire as shown in Fig. 6-1.
- (9) For connecting the terminal block to each terminal, be sure to use a crimp-style terminal with insulation coating.
- (10) Connect securely the motor earth terminal () and the driver earth terminal (), and earth to one point together with the noise filter earth terminal. Earthing the machine main unit is recommended. Earth in Class 3 earthing. (Earthing resistance under 100 Ω, 1.6mm and larger)
- (11) After finishing wiring to the terminal block, close the terminal block cover and fix with screws to prevent electric shock.
- (12) Provide a surge absorbing circuit to electromagnetic contactor, between relay contact points, coil and brake winding of a motor with a brake which are allocated around the position driver, for preventing error.
- (13) Provide a no-fuse breaker to shutoff the power supply outside the position driver in emergency. In case of using an earth leakage breaker, use the one for „Inverter“ provided with high-frequency ability. Rush current protection circuit for capacitor is not provided in the position driver power supply input circuit.
- (14) Provide a noise filter for reducing radio noise and preventing error.

After wiring, check again for miswiring before turning on the power supply.

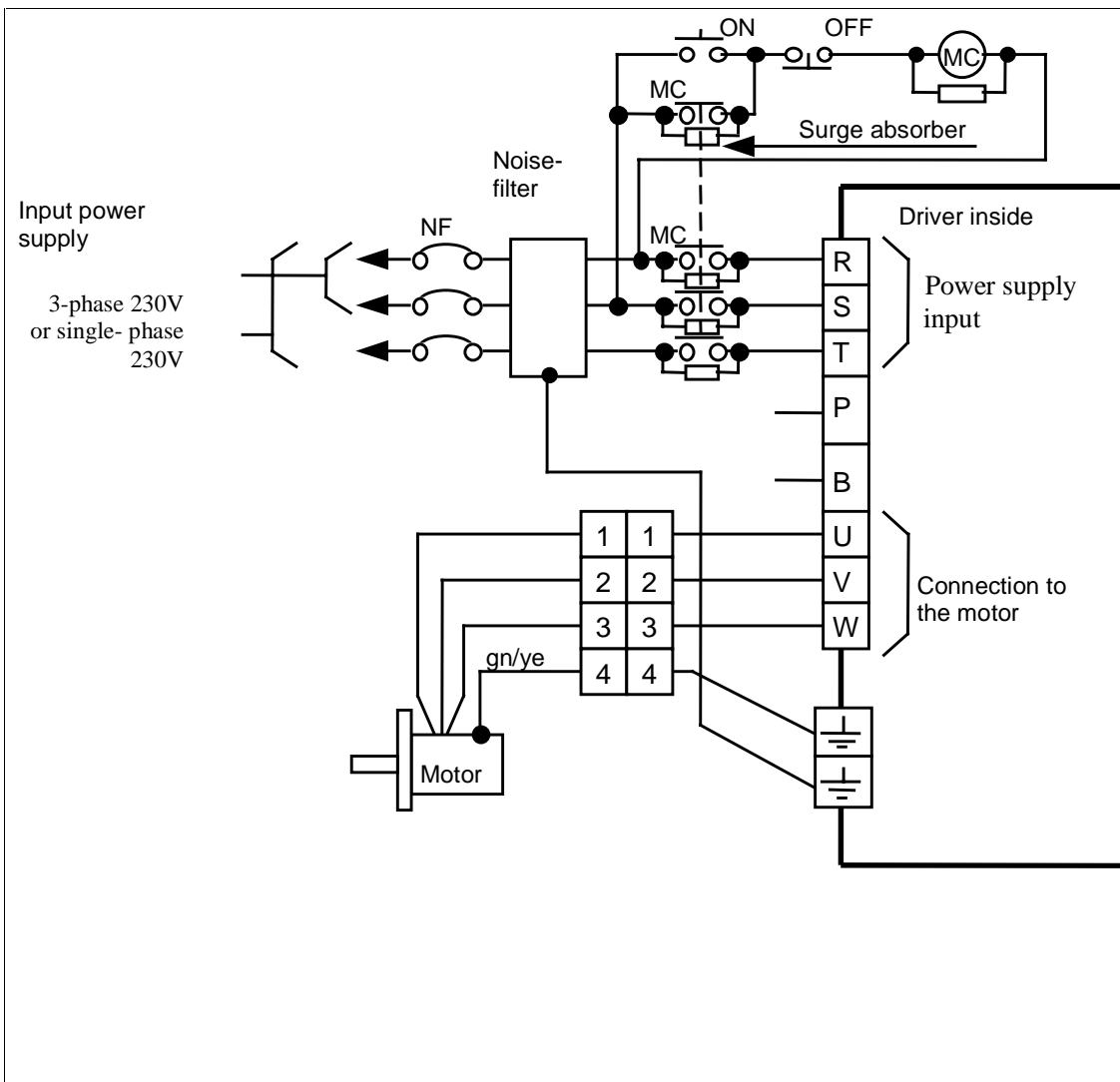



Fig. 3-1 Wiring to terminal block

Applicable motor			Consumed power (in rated loading)	Overcurrent protection unit (Breaker/Rated current)	Recommended noise filter	Main circuit electric wire diameter (RSTUVWE)
Series name	Voltage	Output				
MMD	200V	100W	Approx. 0.3kVA	5A	NFE 1 Phase	1.25mm ²
		200W	Approx. 0.5kVA			1.25mm ²
		400W	Approx. 0.9kVA	10A	NFD 3 Phase	1.25mm ²
		750W	Approx. 1.3kVA			2mm ²

3.1.3. Wiring to connector I/F

- (1) For wiring, refer to Fig. 3-2 "Wiring example to connector I/F".
- (2) Prepare a control signal power supply of DC 12-24V - /0,5A for external control, which is to be connected between COM+ and COM.
- (3) Install the position driver and the peripheral equipment within 3m in to shorten the wiring.
- (4) Separate this wiring from the power lines (R,S,T,U,V,W, ) 30cm or more. Do not pass through the same duct and do not bind together, to prevent error.
- (5) Do not apply more than DC24 V, 50mA to each terminal of the control output (BUSY, ALM, COIN/DCLON P1OUT - P16OUT), nor do not apply voltage in reverse polarity. It may damage the position driver.
- (6) When a relay is directly driven by the control output terminal, install a diode in parallel with the relay in the direction shown in Fig. 6-2. If a diode is not installed nor installed in reverse, the position driver will be broken.
- (7) Either positioning finish signal (COIN) or decelerating output signal (DCLON) can be selected by parameter setting. For details, refer to section 7.2.4 "NC data".
- (8) Frame ground terminal (FG) is connected with the earth terminal () inside of the driver.
- (9) Run-inhibit input signal (limit) is defined as follows; CW-run limit input (CW limit) as the preset limit is activated while the motor runs at CW-direction, CCW-run limit input (CCW limit) as the preset limit is activated while the motor runs at CCW-direction. CW- direction and CCW-direction are defined here as the following:

* Rotating direction, viewed from the motor shaft end (arrow direction)

Machine movement may be reversed even when the motor runs at the same direction, depending on the motor mounting position and method. Also, CW/CCW-limit is normally set to be activated when the input is ON for safety purpose. If the connection is opened by some errors, the input will turn to be OFF and a limit will be activated. When the limit function is not required (such as rotating movement), set parameter No. 09 "Run limit input inactive" to "1."

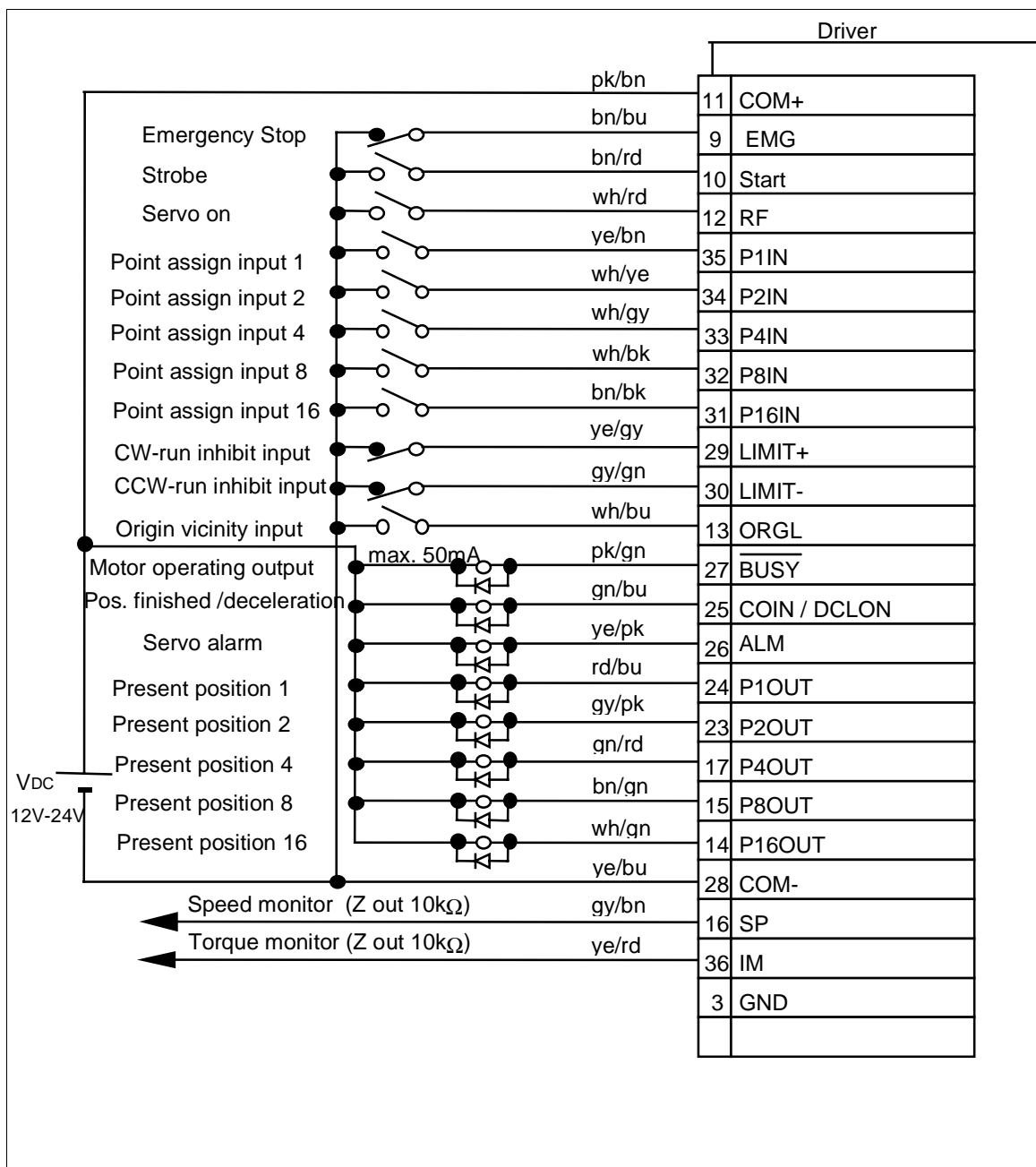



Fig. 3-2 Wiring example to connector I/F

3.1.4. Wiring to connector SIG

- (1) For encoder cable, use a twisted pair wire having overall shield which is a stranded wire having the core of 0.18mm² or more.
- (2) The length of the cable must be within 20m. When the wiring is long, double wiring is recommended to reduce the influence by the voltage drop for 5V (3,4 pin) and 0V (1,2 pin) of the power supply.
- (3) Connect the shield of the relay cable for the position driver side to No.20 pin (FG) of the connector SIG. Connect the shield on the motor side of the relay cable to the shield of the shielding wire from the encoder.
- (4) Separate this wiring from the power lines (R,S,T,U,V,W, ) by 30cm or more. Do not pass through the same duct and do not bind together, to prevent error.
- (5) When using a canon plug, connect the shield housing in the motor side of the encoder cable, to J-terminal.
- (6) Do not connect anything to the vacant terminal (5, 6, 13, 14, 15, 16, 19) of the connector SIG.
- (7) Frame ground terminal (FG) is connected with the earth terminal () inside of the driver.

Connector -Kid Motor: SUP-E01-MMD

Connector :15pol.	(Encoder)
Connector 4pol.	(Motor)
Connector 2pol.	(Brake)

Connector -Kid Driver: SUP-E01-DMD

Connector 20pol. with housing	(Encoder)
Connector 36pol. with housing	(In.-Output)

Cabel-Kid:

Motorcabel	IKL 0210
Encodercabel	IKS 0196
Brakecabel	IKL 0211
Interfacecabel	IKS 0199
Cabel In/Output	IKS 0197

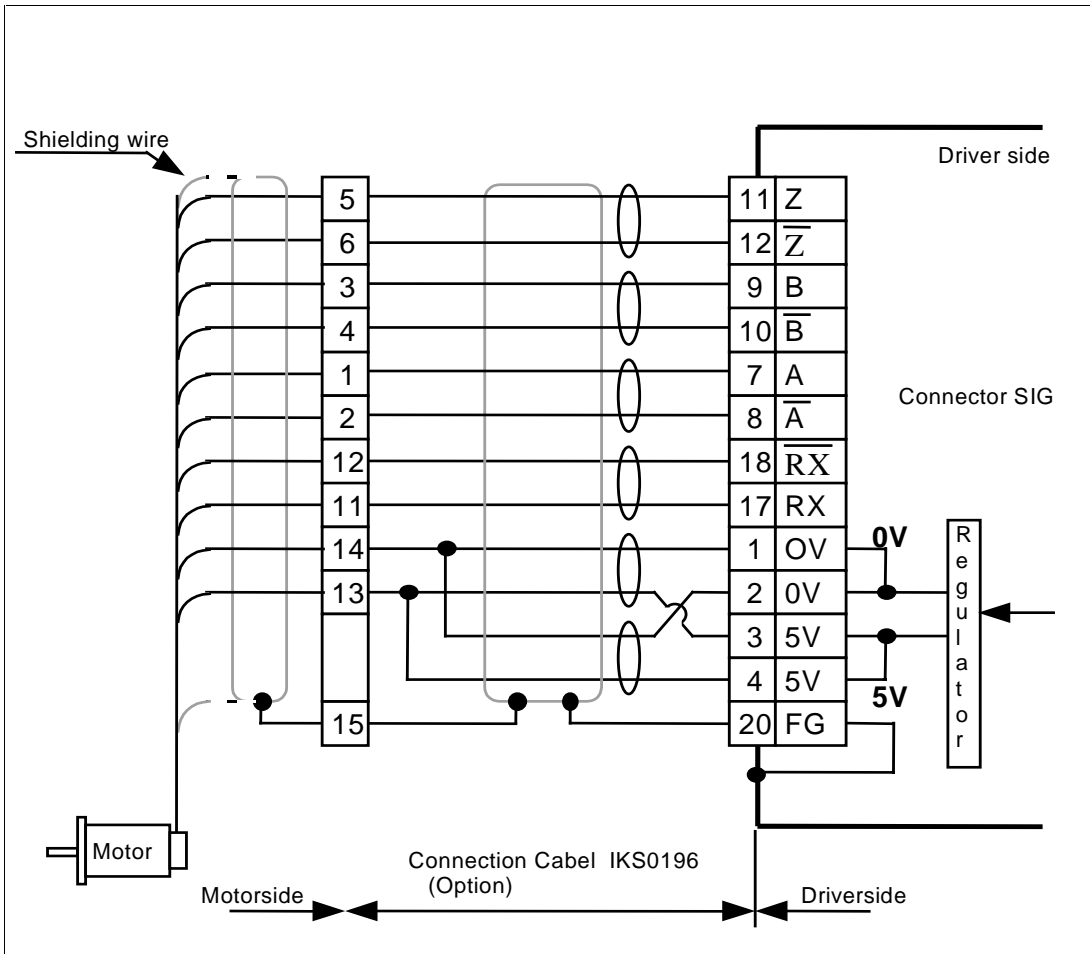

Fig. 3-3 Wiring example to connector SIG

3.1.5. Wiring to connector SER

- (1) This position driver can be used, combining the console (option) or marketed personal computers specified in section 8 "Communication function".

The following functions are available in combination with a personal computer:

- * NC parameter setting/change
- * Various servo parameter setting/change
- * Monitoring of control state
- * Referring to alarm state
- * Referring to alarm record
- * Automatic gain tuning
- * Waveform graphic function
- * Parameter data save/load

Note) As connector SER2 cannot be used, do not connect a cable to the connector SER2.

- (2) For connecting the personal computer and the position driver, use the special cable prepared as an option.

3.2 Wiring device selection

Applicable motor			Consumed power	Overcurrent protection unit	Recommended noise filter	Main circuit electric wire diameter
Series name	Voltage	Output	(in rated loading)	(Breaker/Rated current)		(RSTUVWE)
MMD	200V	100W	Approx. 0.3kVA	5A	NFE 1 Phase	1.25mm ²
		200W	Approx. 0.5kVA	10A		1.25mm ²
		400W	Approx. 0.9kVA		15A	NFD 3 Phase
		750W	Approx. 1.3kVA	2mm ²		

4 Function

4.1 Details of input/output signals (Connector I/F)

Type	Application signal name	Symbol	Connector Pin No.	Contents
	Control signal power supply	COM +	11	Connect „+“ pole of the control signal power supply (12-24V) to COM+ (pin 11) and the „-“, pole to COM- (pin 28). Prepare a control signal power supply at customers. Power supply capacity differs according to the control output circuit structure. Prepare a power supply with sufficient margin. (Power supply capacity: 500mA or more)
		COM -	28	
	Emergency stop input	EMG	9	Normally, connect this input to COM- of the control signal power supply. Opening the connection to COM- makes emergency stop error, and the position driver protective function will be activated. For resetting the emergency stop error, turn on the power supply again.
	Strobe signal input	STB	10	Normally, make this input open. When connecting this to COM- of the control signal power supply, the position driver reads a signal of point assign input to start its operation. Allow 10ms. or longer, before entering a strobe signal(STB) to COM-, after setting a point assign input.(Otherwise, the position driver may not read a point assign input correctly.) Enter a STB signal for 10ms. or longer. To confirm that the STB signal is definitely received, compose a sequence so as to return the STB signal to the open-state after receiving BUSY signal from the position driver. Refer to section 9.6 "Interface timing".

	Servo-ON signal input	SVON	12	<p>By connecting this input to COM- of the control signal power supply, the position driver becomes Servo-ON state.</p> <p>By making the connection to COM- open, the position driver becomes Servo-OFF state to shutoff the power supply to the motor and to activate a dynamic brake, and the deviation counter will be cleared.</p> <p>Note 1) During transition from Servo-OFF to Servo-ON, be sure to check that the motor is at standstill.</p> <p>Note 2) To prevent transient troubles, be sure to turn the power supply ON/OFF at Servo-OFF state.</p> <p>Note 3) Allow 120ms or longer before entering a command, after shifting to Servo-ON state.</p> <p>Note 4) When turned to Servo-OFF state, the position driver control state shifts to reset state. To make stepping, execute the origin return command again. However, it is possible to keep the control state at Servo-ON with an option setting. For details and cautions, refer to section 9.8.3 "Control state selection at Servo-OFF".</p> <p>Note 5) As frequent repetition of Servo ON/OFF may damage the built-in dynamic brake circuit in the position driver, avoid such operation.</p>
	Point assign input	P1IN - P16IN	35,34, 33,32,31	Enter e position driver command. For details of the command, refer to section 9. "Operation".

Type	Application signal name	Symbol	Connector Pin No.	Contents
	CW-run limit input	CWL	29	<p>□ In such a case as a linear drive etc., compose the circuit so as to connect this input to a limit switch for CW-direction(viewed from the motor shaft), and this limit switch is closed during a normal run.</p> <p>□ CW-torque will not be generated when the motor position exceeds the limit and the CW-limit switch is opened, while the origin return is not completed.(However, it is possible to allow the torque generation and inhibit the pulse output alone by option setting). For details and cautions, refer to section 9.8.4 "Torque output selection at limit signal input" .</p> <p>Hardware limit input error(55) occurs if the switch is opened, exceeding the limit at origin return completion.</p> <p>Always connect this to the COM- of the control signal power supply, when the limit switch is not used.</p> <p>Dynamic brake can be activated with this input. For details, refer to section 4.3 "Dynamic brake" .</p>
	CCW-run limit input	CCWL	30	Inhibit action to CCW with this input. For functions and composition, refer to the above "CW-run limit input."
	Origin vicinity input	ORGL	13	<p>Connect so as the origin vicinity input is closed when the position is within origin vicinity.</p> <p>Note) For origin vicinity input, wire to connect to COM- at the position 180 degrees before Z-phase.</p>
	Motor running state output	BUSY	27	Transistor will be turned OFF while the position driver is processing the run command.
	Positioning complete output	COIN	25	<p>This output signal can be used either as positioning complete output (COIN) or decelerating output (DCLON) with a parameter. (Refer to section 7.2.4 "NC data" for setting contents.)</p> <p>Transistor will be turned ON while reserved pulse amount of the deviation counter is in the range set by user parameter No. 22 "Positioning complete range."</p>
	De-celerating output	DCLON	25	<p>This output signal can be used either as positioning complete output (COIN) or decelerating output (DCLON) with a parameter. (Refer to section 7.2.4 "NC data" for setting contents.)</p> <p>Transistor will be turned ON while the motor is decelerating.</p>
	Servo alarm output	ALM	26	Transistor will be turned OFF by detecting an error to activate a protective function.
	Present position output	P1OUT - P16OUT	24,23, 17,15,14	<p>Outputs the present motor position (point No.).</p> <p>All transistors will be turned OFF when the power supply is turned on, alarm occurs and the reset command is executed.</p> <p>All transistors will be turned ON when the origin return command is completed.</p>

	Velocity monitor signal	SP	16	<p>Outputs a voltage with polarity in proportion to the motor speed and the position deviation. Changeover of the motor speed and the position deviation is possible with parameter No. 08 "Velocity monitor gain selection" and No. 3B "Monitor signal selection." Refer to section 7.3 "Details of servo parameter" (User parameter).</p> <p>+: CCW run/deviation -: CW run/deviation</p> <p>Two types of full scale value of the velocity monitor signal can be to with parameter No. 08 "Velocity monitor gain selection." Refer to section 7.3 "Details of servo parameter" (User parameter).</p> <p>Note) Output impedance of the velocity monitor signal is 10k. Pay attention to the input impedance for the measuring instrument and the circuit to be connected.</p>
		GND	3	
	Torque monitor signal	IM	36	<p>Outputs a voltage with polarity in proportion to generated torque of the motor.</p> <p>+: CCW torque -: CW torque</p> <p>A relationship between the torque monitor signal output voltage and the generated torque, Approx. 3V/100% torque</p> <p>Note) Output impedance of the torque monitor signal is 10k. Pay attention to an input impedance for the measuring instrument and the circuit to be connected.</p> <p>This is connected to the earth terminal of the driver.</p>
		GND	3	
	Frame ground		18	

4.2 Input/output circuit configuration

4.2.1. Control input

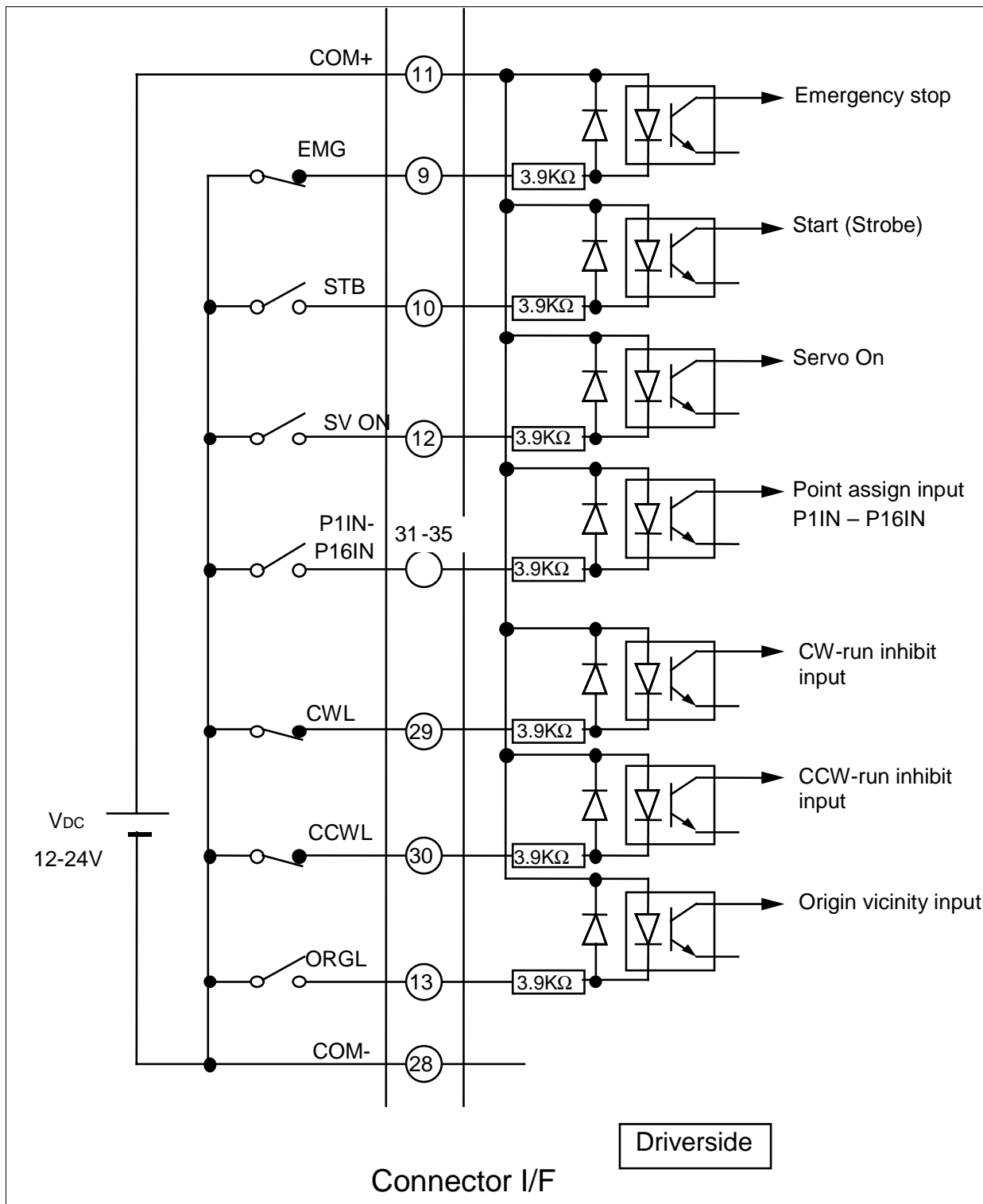

Fig. 4-1 Control Input

4.2.2. Control output

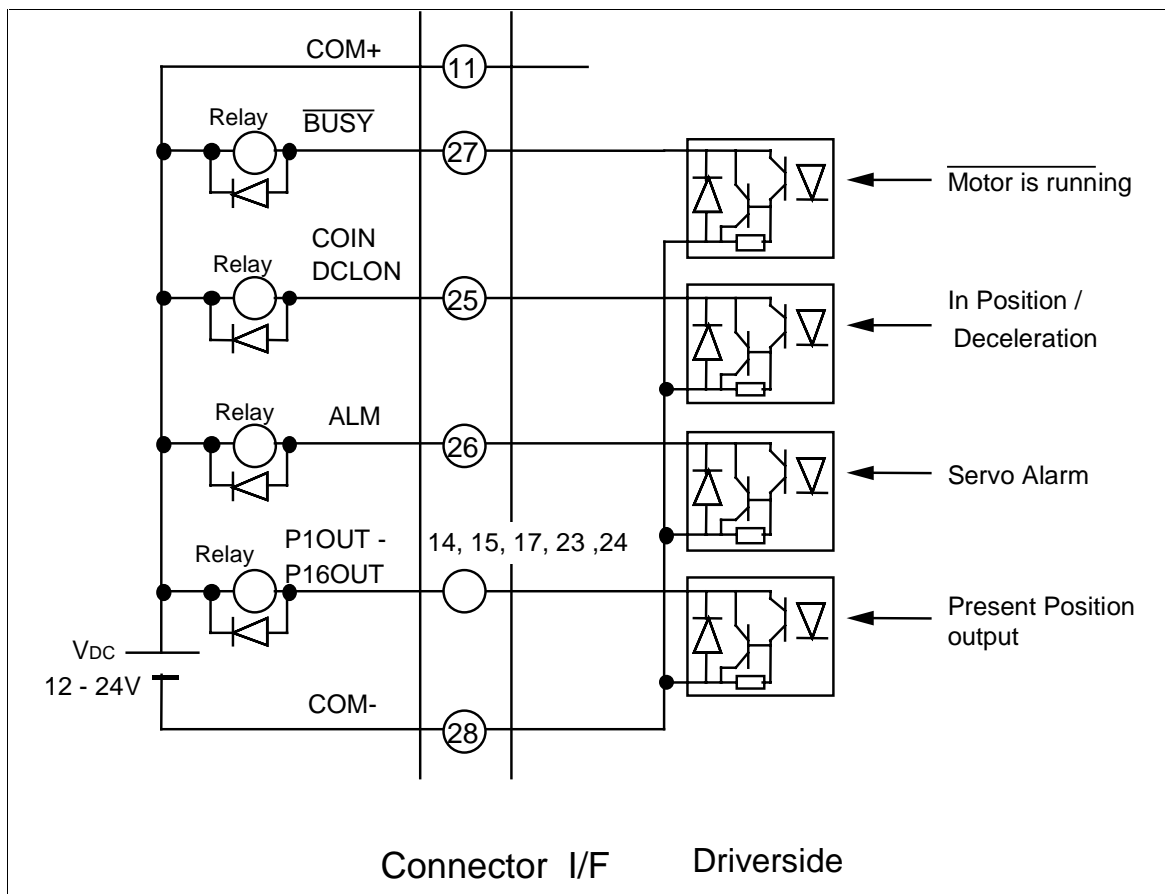

Fig. 4-2 Control output

- (1) Prepare a power supply (V_{DC}) for the control signal at customer side. (DC12 - 24V, 0.5A or more)
- (2) Pay attention to the polarity of V_{DC} . Reversed polarity of the above figure 4.2 for the connection will damage the position driver.
- (3) When a relay is driven directly by each output signal, install a diode in parallel to the relay as shown in Fig. 4.2. The position driver will be damaged with no diode installation, or reversed installation.
- (4) When each output signal is received by a logic circuit such as a gate, be sure to avoid influence by the noise.
- (5) The current fed to each output should be 50mA or less.

4.2.3. Analog signal output (Monitor output)

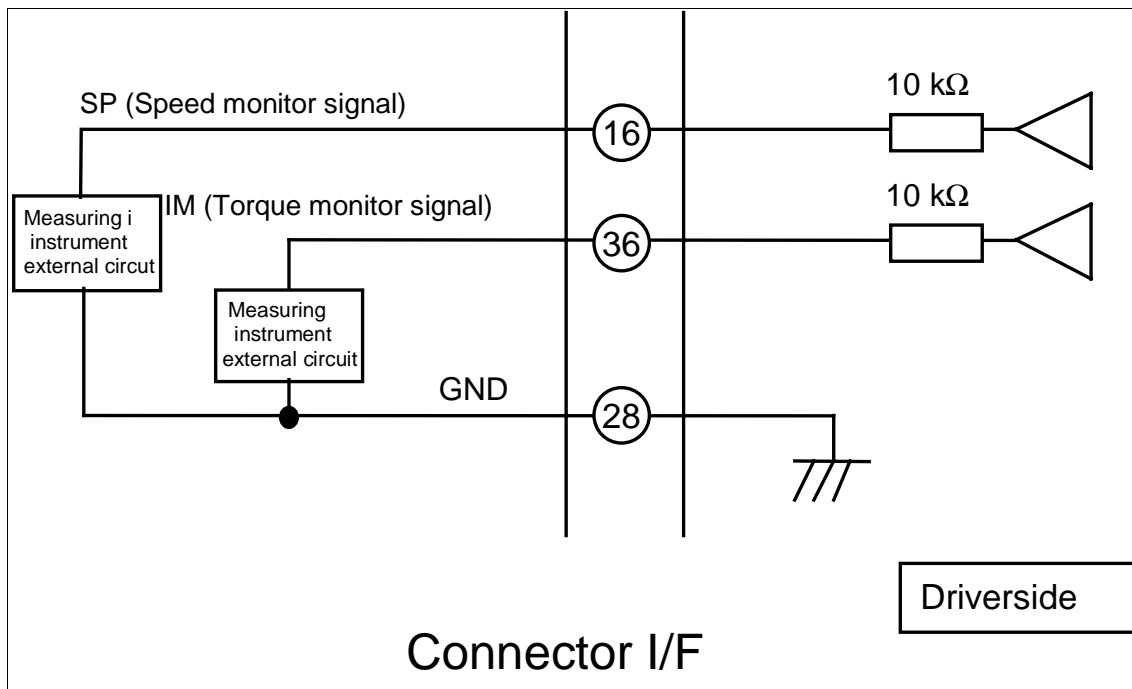

Fig. 4-3 Analog output

- (1) As shown in the above figure, SP output and IM output have 10k of output impedance respectively. In case of connecting the measuring instrument or the external circuit to SP/IM output, connect a measuring instrument with high input impedance (Multi meter, oscilloscope, etc.) to reduce the tolerance.

4.3 Dynamic Brake

DMD* series is equipped with a built-in dynamic brake for emergency stop.

The dynamic brake will be activated in the following cases:

- (1) when the power supply is turned off.
- (2) at Servo-Off.
- (3) when a protective function is activated.
- (4) during deceleration, and when the limit switch connected to CW-run limit input (CWL) of connector CN I/F is opened(at CW-running).
- (5) during deceleration, and when the limit switch connected to CCW-run limit input (CCWL) of connector CN I/F is opened(at CCW-running).

Note1) In case of the above (2) (3) (4) (5), selection or not of the dynamic brake activation can be made with parameter No. 0A, 3D, and 3E. (Refer to section 7.3 "Details of servo parameter (User parameter)".

Sequence at run limit input	:	Parameter No. 0A
Sequence at alarm	:	Parameter No. 3D
Sequence at Servo-Off	:	Parameter No. 3E

Note2) The dynamic brake is provided with short-time rating, and is used only for emergency stop.

Specifically, as frequent repetition of Servo ON/OFF may damage the built-in dynamic brake circuit in the position driver, avoid such operation.

4.4 Automatic gain tuning

4.4.1. Summary

The driver sets the most appropriate gain automatically, by operating the motor with a certain pattern and by presuming the load inertia from the torque required at the time.

4.4.2. Applicability

This function is available only when the following conditions are satisfied. Even if they are satisfied, there may be some cases this function cannot be applied, depending on the load condition. In such cases, set it manually.

	Applicable conditions
Load inertia	It should be greater than 3 times but smaller than 15 times of the motor(rotor) inertia and should not be greatly fluctuated.
Load	Machine stiffness should be as high as possible, including coupling to the motor (No belt drive is applicable.). Backlash of a gear should be as small as possible. There should not be no unbalanced load of more than 1/4 of the rated torque. (Especially when used at the vertical axis) Viscous load torque should be less than 1/4 of the rated torque. There should not be safety problem and machine damage to be expected, even at oscillation state. There should not be no problem with two revolutions for CCW, and with two revolutions for CW in both forward and reverse directions.

4.4.3. Notices

- (1) During automatic gain tuning, the motor output torque is allowed up to the maximum torque set with parameter No. 06.
- (2) Oscillation state occurs depending on the loading state. Take enough care for the safety. When oscillation occurs, shutoff the power supply immediately, or turn to Servo-Off.
- (3) If abnormal situation occurs during automatic gain tuning, shutoff the power supply immediately, or turn to Servo-Off.
- (4) When the load inertia cannot be presumed even if automatic gain tuning is executed, the gain value remains the same value as that of before tuning, and does not change.
- (5) After completing automatic gain tuning, note that the position driver becomes "reset state." (For the position driver state, refer to section 9.3 "Position driver state transition".

4.4.4. Automatic gain tuning operation

- (1) Set the machine stiffness No., (Higher the setting No., stiffer the tuning) and execute to start automatic gain tuning.
- (2) Turn the motor 2 revolutions to CCW and 2 revolutions to CW for 2 times.(This constitutes one cycle). Repeat 5 cycles at the maximum.
- (3) Operation acceleration will be increased by double per one cycle from the 3rd. cycle. Depending on a loading state, there may be some cases such that automatic gain tuning will be completed before 5 cycles, or the operation acceleration will not change. These are not considered as malfunctions.

About machine stiffness No.

This No. represents the stiffness of the machine, and ranges from 1 to 9.

To the machine with high stiffness, higher value and higher gain can be set.

Normally start setting from smaller No. to larger one gradually, and repeat automatic gain tuning before you encounter oscillation, abnormal noise or vibration.

4.4.5. How to operate

- (1) Shift the load to an position where no problem is found even with 2 revolutions of the motor.
- (2) Inhibit the command.
- (3) Turn to "Servo-ON."
- (4) Start up automatic gain tuning.
In case of starting automatic gain tuning with MINITERM for DMD*, refer to the instruction manual provided with MINITERM.
In case of executing automatic gain tuning with the front panel, refer to section 10.3.8 "Automatic gain tuning".
- (5) Write-in to EEPROM if no problem is found.

Note) If "Alarm" occurs or "Servo-Off" is entered during automatic gain tuning operation, it will lead to an automatic gain tuning error.

4.5 Protective function

4.5.1. Summary

- (1) Protective function operation
DMD* has various protective functions. If this protective function is activated, servo alarm output (ALM) turns from ON to OFF and the driver turns to TRIP state. (Protective function is activated and the motor stops.)
- (2) State display
When protective function is activated with DMD*, present error code will be displayed with flashing on 7 segment LED of the front panel. When the console is used, error code and error name will be displayed on the console display. By using the communication function (Section 8. "Communication Function, error state can be confirmed on the monitor of personal computer.

4.5.2. Details of protective function

Some error factors can be reset by giving a reset command to restart the position driver (Note1). For other factors which cannot be reset, the power supply must be turned on again.

Protective function	Error No.	LED Display	Contents	Solution
Over-voltage protection	12	No. flash	Voltage in the converter section is increased by regenerative energy. With 200V machine type, voltage became approx. 400VDC or more, and with 100V machine type, it became approx. 200VDC or more.	Set the deceleration time longer or decrease the load inertia. Note) This function cannot be applied for cases using regenerative brake continuously.
Under-voltage protection	13	No. flash	Power supply voltage dropped because of instantaneous power shutoff or insufficient power supply capacity.	Check if the power supply voltage is within permissible range. Note) Pay attention to insufficient power supply capacity, voltage drop by rush current at power on, or open phase of the power supply.
Overcurrent protection	14	No. flash	Output current in the converter section increased abnormally.	After shutting off the power supply completely, check the short circuit of the motor connection cables U, V, W. Check insulation resistance between the motor connection cables U, V, W and the motor earth E, and also check the deterioration of insulation of the motor. When overcurrent protection is still activated at power-ON, immediately shutoff the power supply as there have been a trouble.
Overload protection	16	No. flash	The position driver was used continuously with load over the rated current value.	Check if the motor connection cables U, V, W are not disconnected. Lower the gain. Set the acceleration/deceleration time longer or lower the load. Use the larger capacity motor and the position driver.

Detector error	17	No. flash	Hardware error of the power supply detector was detected.	Turn off the power supply, and turn it on again.
Excessive position deviation protection	24	No. flash	Position deviation pulse exceeds the allowable range set by the parameter No. 23 (Position error limit).	Enter run command to check if the motor runs. Check the output torque with the torque monitor, and check if the output torque is not saturated. Set the user parameter No. 06 "Torque limit" to the maximum value. Check the gain adjustment according to the adjusting method. If there is no problem for the above points, set the acceleration/deceleration time longer and lower the speed with lighter load.
			<input type="checkbox"/> Position deviation pulses exceed the preset permissible range with parameter No. 39, „Excessive position deviation at Servo-Off“, when Servo-On signal input is turned ON.	User parameter No.3E, „Sequence at Servo-Off „, is set so as to retain the deviation counter. External force is applied to the motor at Servo-Off and the position is shifted. The driver turns to Servo-Off during running(jogging, stepping)
Deviation counter overflow	29	No. flash	The position deviation pulse becomes more than $2^{27}=134217728$.	Check the same in the above.
Over-velocity protection	26	No. flash	Motor speed exceeded the overvelocity level set by the system parameter.	Check if the velocity data contents are too large. Check if overshoot occurs at acceleration due to the gain adjustment failure.
Run inhibit input protection	38	No. flash	The driver trips if both CW and CCW-run limit inputs are turned off, by judging it as an error.	Check if there are no errors for switches of CW and CCW-run limit inputs, the cable and the power supply. Specifically, check if the start-up of the control signal power supply (12 - 24VDC) is slow. Set the user parameter No. 01 "Rise delay time" large. Check the setting of the limit input logic.

Encoder connection error	21	No. flash	The driver trips when the encoder connection error was found after turning on the power supply. (Normal reception is not made at all.)	<p>Check the connection between the position driver and the encoder, connection error and the connection state of the connector SIG.</p> <p>Check the power supply voltage ($5V \pm 5\%$) on the encoder side.</p> <p>To return, reset the power supply.</p>
Encoder communication error	22	No. flash	The driver trips when the encoder connection error was found after turning the power supply on such as breaking of the wire, etc.	<p>Check the connection between the position driver and the encoder, connection error and the connection state of the connector SIG.</p> <p>Check the power supply voltage ($5V \pm 5\%$) on the encoder side.</p> <p>To return, reset the power supply.</p>
EEPROM error protection	36	No. flash	Error occurs in such a case as data is broken when reading data from EEPROM at the power-ON.	Reset all parameters, and write in EEPROM.
Origin return error	51	No. flash	Abnormal limit signal was entered during the origin return operation or the driver is not turned to Servo-ON.	<p>Check if there are no errors for switches of CW and CCW-run limit inputs, the electric wire and the power supply.</p> <p>Check if the motor is at Servo-ON.</p> <p>Check the setting of the limit input logic.</p>
Velocity/ Acceleration undefined error	52	No. flash	Velocity data or acceleration data to be operated are not set.	Check the setting of the velocity data and the acceleration data.
Emergency stop input error	53	No. flash	The driver trips if the emergency stop input is turned off, judging it as an error.	<p>Check if there are no errors for switches of the emergency stop input, the cables and the power supply.</p> <p>Specifically, check if starting the control signal power supply (12-24VDC) is slower compared to that of the position driver.</p> <p>Check the setting of logic of the emergency stop input.</p> <p>To return, input the reset command or reset the power supply. (Select with parameter: Note 5)</p>

Step data undefined error	54	No. flash	Step data of the step command to be operated is not set.	Check the setting of the step data.
Hardware limit input	55	No. flash	The driver trips when the limit at running direction is entered after the origin return is completed and position cannot be held.	Check if CW, CCW-run limit input is wired in reverse. Check if there are no errors for switches of CW and CCW-run limit inputs, the cable and the power supply. Check the setting of the limit input logic.
Software limit error	56	No. flash	The driver trips if the motor position exceeds the software limit setting range after completing the origin return.	Check the step data and the running sequence. Check the software limit range.
Present position overflow error	57	No. flash	The driver trips if the motor position exceeds the range of - 1073741824 - 1073741823 after completing the origin return. (Note 6)	Check the step data and the running sequence.
System error protection	98	Red flashes	The driver trips if the self-diagnostic function of inner system judges that there may be a possibility of some error.	Turn off the power supply once, and turn it on again. If it trips showing the left indication, there may have been a trouble. Shut off the power supply immediately.
CPU error protection	30	Red flashes		
Other error protection	99	Red flashes		

Note1) To return from the trip state, turn off the power supply and remove the cause, and then turning it on again, or by entering the reset command. (Position driver control state will be shifted to the reset state. Refer to section 9.3 "Position driver state transition". However, when the following protective functions are activated, reset command cannot cleared then.

Encoder connection error - Encoder communication error -
Emergency stop input error (Note 5)

System error protection - CPU error protection - Other error protection

In these cases, reset by turning the power supply on again.

- Note 2) When EEPROM parameter error protection is activated, turn the power supply on again, check and set all parameters.
- Note 3) Overload protection can be reset by executing the reset command 10 seconds after the alarm occurs.
- Note 4) Parameter change while undervoltage protection is working cannot be stored in EEPROM, and becomes inactive after shutting off the power supply.
- Note 5) If emergency stop error (53) occurs, it can be returned only by resetting the power supply at initial setting state(factory setting). To return with the reset command, change NC parameter. (Refer to section 7.2.4 "NC data".)
- Note 6) By setting the optional function for NC parameter, it is possible to make the present position overflow error (57) inactive. (Refer to section 7.2.4 "NC data".)
If the present position overflow error is made inactive, absolute position transfer cannot be used with step command.

5 Operation

5.1 Inspection before operation

- (1) Is wiring made correctly?
Are there any error connections and loose connection(fastening) for terminals R,S,T of the power supply input and terminals U, V, W,

 of the motor output?

- (2) Is the input power supply correct as the rating?
- (3) Are there any portion with short-circuit due to the electric wire chips, etc.?
- (4) Are screws and terminals not loosened? Are connectors inserted securely?
- (5) Are motor connection cables not short-circuited or grounded?

5.2 Trial operation

- (1) Conduct the following operations for the safety.
Set the motor under no load condition (Nothing is connected to the shaft.).
If rapid accelerating/decelerating operation is performed, it is dangerous that the motor moves because of the reaction. Be sure to fix the motor.
- (2) In case of using a motor with a brake, be sure to release the brake.
- (3) Set the polarity of signals connected to the connector I/F input signal pins and switches as shown in Fig. 3.1, and apply control signal power supply (DC12 - 24V).
- (4) Turn on the power supply of the position driver.
LED on the front panel displays any of the followings according to the setting value for parameter No. 01 "LED initial state."

P	0	... Positiondeviation
r	0	... Motorspeed
t	0	... Torque output
Id	1	... ID Nr.
P	-----	... Present Position
IN	0-A	... Input / Output -Signal
ERR	---	... Error-Nr.
U	1.00	... Parameter used by manufacturer

At the time, if there is an error in the position driver, the error code will be displayed, flashing LED.

Err.53

In this case, provide suitable correction after shutting off the power supply, and then turn the power supply on again.

- (5) Enter a Servo-ON signal to make the motor ready to run.
- (6) For the motor operation, refer to section 9.2 "Initial setting of NC parameter" to set NC parameters and run the motor.
- (7) Try parameter change and gain adjustment.

6 Adjustment

6.1 Confirmation of rotary encoder voltage

This driver has built-in power supply for rotary encoder. To operate the rotary encoder normally, the power supply voltage needs to be in the range of $5V \pm 5\%$.

If the cable for the rotary encoder connection is too long, it may not be in the above range because of the voltage drop. Take measurement of the rotary encoder voltage near the motor (Between 13 pin (+5V) and 14 pin (0V) of relay connector for the encoder, or between H terminal (+5V) and G terminal (0V) of canon plug / Fig. 3.3 Wiring example to connector SIG) and confirm if it is in the range of 4.75V - 5.25V. IF it is under 4.75V, see section 3.1.4 "Wiring to connector SIG" and make double wiring for the rotary encoder.

6.2 Gain adjustment

Although DMD* Series are equipped with an automatic gain tuning function, readjustment may be necessary in case that adjustment cannot be done finely even with this function due to restrictions such as loading conditions, etc., unfavorable phenomena such as vibration and noise generated when stopping and operating, or optimum response and stability are desired to meet the load respectively. In these cases, readjust according to section 6.2.1 "Gain adjustment principle".

DMD* Series are of digital AC servo structure. However, for the adjustment method of servo gain, it is designed to be able to use experience on the adjustment of the conventional analog servo driver. Fig. 6.1 shows an image of equivalently-converting the DMD* Series servo control section to the conventional analog servo method.

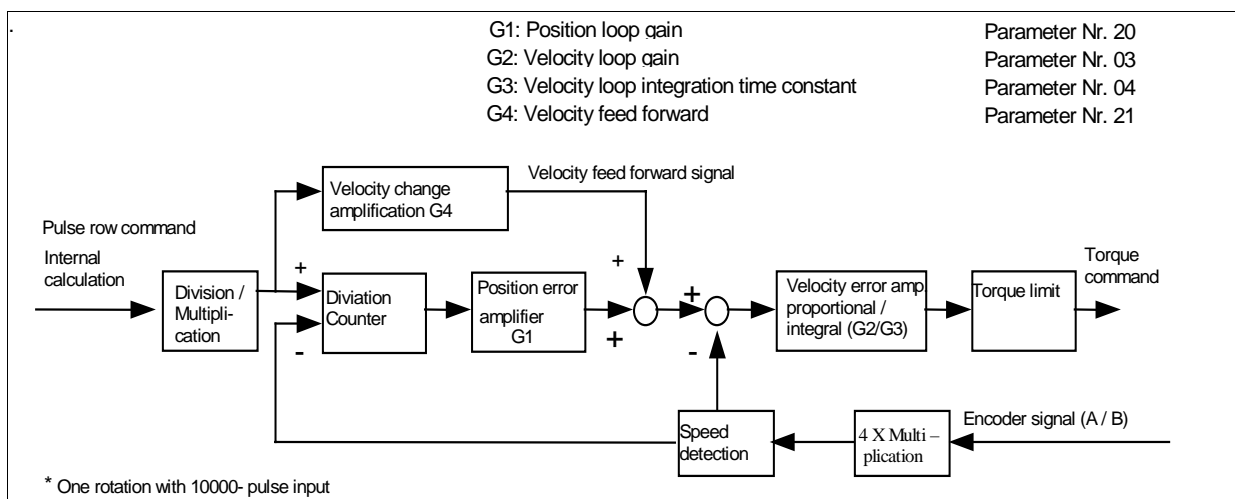

Fig. 6.1 Equivalence block diagram

6.2.1. Gain adjustment principle

- (1) Set velocity feed forward to the minimum value (0%) with user parameter No. 21, referring to section 7.1.2 "Servo parameters" and section 8 "Communication function".
- (2) Then, set velocity loop gain as large as possible within a range of not causing oscillation, with user parameter No. 03.
- (3) Then, set position loop gain as larger as possible within a range of not causing oscillation, with user parameter No. 20.
- (4) Then, set velocity loop integration time constant as small as possible with user parameter No. 04 as needed. Smaller the value, faster the speed for making positioning deviation to 0.
- (5) Finally, only in case that extremely faster response velocity is required, gradually increase velocity feed forward gain with user parameter No. 21. However, if it is too large, speed overshoot will be increased.

Setting example of gain) In case of having relatively high stiffness such as for ball screw,

Position loop gain:	100-200
Velocity loop gain:	150-300
Velocity integration time constant:	20-50

6.2.2. Notices in gain adjustment

- (1) Optimum value for gain setting widely varies based on the load. When the loading condition is changed greatly, readjustment is necessary.
- (2) When using velocity loop integration time constant at the maximum value (1000ms.), it may not enter within the positioning complete range set by user parameter No. 22, and positioning complete signal (COIN) may not be generated. Normally, set it "100ms." or smaller.
- (3) Excessive gain setting could result in oscillation. At the time, immediately lower the gain setting to stop the oscillation. If the oscillation does not stop in any way, turn the power supply off once to turn the servo-on command off, turn the power supply on again, lower the gain setting and resume from the beginning.

7 Parameter

7.1 Summary of parameter

DMD* Series has servo parameters for adjusting and setting properties and functions, and NC parameters for storing position information, velocity information and acceleration/deceleration time for positioning.

Use a front panel, console(option) or personal computer to set/change parameters, and confirm the contents of these parameters.

There are some limitations on parameters which can be set with a console.

7.1.1. NC parameter

- (1) There are following four kinds of NC parameters:
 - a) Step data which stores the positioning information for stepping
 - b) Velocity data which stores the stepping velocity, jogging velocity and origin return velocity
 - c) Offset data which stores origin offset and software limit
 - d) NC data which stores other acceleration/deceleration time, operation direction, etc.
- (2) For details of NC parameters, refer to section 7.2 "Details of NC parameters".
For initial setting method of NC parameters, refer to section 9.2 "Initial setting of NC parameters".
- (3) In case of setting each parameter with MINITERM for DMD*, refer to the attached instruction manual for MINITERM.

7.1.2. Servo parameters

- (1) There are following two kinds of servo parameters:
 - a) User parameters which can be set and changed by customers.
 - b) System parameters which can be referred to but cannot be set and changed by customers.

Among servo parameters, part of parameters such as gain can be set by a console. However, to set all parameters, front panel or MINITERM for DMD* with personal computer must be used.

- (2) A list of servo parameters is shown below. For details of individual parameters, refer to section 7.3 "Details of servo parameters (User parameters)".

Type	Parameters No.	Parameters name	Range	Standard factory setting	Console edit
User parameter	00	Name of axis	0 - 31	0	
	01	LED initial display	0 - 7	1	
	03	Velocity loop gain	25 - 3500	100	
	04	Velocity loop integration time constant	1 - 1000	50	
	05	Velocity detection filter	0 - 4	4	
	06	Torque limit setting	0 - 300	*	
	08	Velocity monitor gain (selection)	0 - 1	0	
	09	Invalidation of run inhibit input	0 - 1	0	
	10	Startup delay time	0 - 600	0	
	20	Position loop gain	0 - 1000	*	
	21	Velocity feed forward	0 - 100	0	
	22	Positioning complete range	0 - 32766	10	
	23	Excess pos. deviation setting	1 - 32766	30000	
	24	Excess pos.deviation error inactive	0 - 1	0	
	2A	Torque filter time constant	0 - 2500	0	
	2B	Feed forward filter time constant	0 - 6400	0	
	30	2 nd . velocity loop gain	25 - 3500	0	
	31	2 nd .velocity loop integration. time const.	1 - 1000	0	
	32	2 nd . position loop gain	10 - 1000	0	
	33	2 nd . gain action setting	0 - 1	0	
	34	2 nd . gain changeover delay time	0 - 10000	0	
	39	Excessive pos.deviation at Servo-Off	1 - 32766	1000	
3B	Velocity monitor signal selection	0 - 1	0		
3D	Sequence at alarming	0 - 3	0		
3E	Sequence at servo-off	0 - 7	0		

System parameter	00	Motor poles	<p>These parameters are determined by the manufacturer depending on the specifications of applied motor, mode type of the position driver, etc.</p> <p>Setting values for these parameters cannot be changed.</p>
	01	Encoder pulse number	
	02	J/T ratio	
	05	Overvelocity level	
	06	Max. torque setting	
	07	Overload time constant	
	08	Overload level	
	09	Undervoltage detection level	
	0A	Overvoltage detection level	
	0B	Regenerative voltage detection level	

Note 1) "Standard factory setting" may differ from the values shown in the above depending on the applied motor.

Note 2) Factory setting of parameters with * mark differs per each model.

Note 3) Note that some parts such as parameter No., setting range, and setting contents are different from those of the conventional type DMD* series.

7.2 Details of NC parameters

7.2.1. Step data

Define the positioning data at step command execution . Point numbers are 128, and refer the table below for the contents.

When positioning is executed without defining step data, step data undefined error (54) occurs.

Item	Setting range	Contents
Position data	-1073741824 - 1073741823 (pulse)	Enter the coordinate data for positioning.
Velocity selection No.	1 - 10	Velocity selection No. for positioning, to be set by velocity data.
Positioning mode	ABS/INC	Designate positioning method either by ABS (Absolute position) or INC (Relative position)

Note) Positioning mode becomes inactive when "Relative travel use only" is selected with optional setting of NC parameter. (It will always be a relative position command.)

7.2.2. Velocity data

When each corresponding command is executed without defining velocity data, velocity/ acceleration undefined error (52) occurs.

Item	Setting range	Contents
Origin return velocity	5 - 500 (kpps)	Decide the motor velocity at origin-returning. Velocity for detecting Z-phase is fixed to 5 kpps.
Stepping velocity 1-10		Decide the motor operation velocity designated by velocity selection No. in the step data. It is possible to store 10 velocities.
Jogging velocity (low speed)		Decide the velocity at low-speed jogging.
Jogging velocity (high speed)		Decide the velocity at high-speed jogging.

7.2.3. Offset data

Item	Setting range	Contents
Origin offset	- 1073741824 - 1073741823 (pulse)	<p>Enter an origin offset by travel amount from the machine origin position. For details, refer to section 9.8.1 "Origin return offset functions."</p> <p>To travel the motor automatically from the machine origin position to the origin offset position at origin return completion, set with option setting for NC parameter "Action selection at origin return complete." For the motor action, refer to section 9.8.1 "Origin return offset functions" and for setting method, refer to section 7.2.4 "NC data" .</p> <p>This parameter becomes active after resetting the power supply.</p>
+direction software limit	0 - 1073741823 (pulse)	<p>Set the max. travel amount of + and - direction. If the motor exceeds the software limit at origin return completion, software limit error (56) occur. When the software limit value is 0, software limit for the direction becomes void.</p>
-direction software limit	-1073741824 - 0 (pulse)	

7.2.4. NC data

Item	Setting range	Contents
Stepping acceleration time	10 - 2000 (ms)	Set the acceleration/deceleration time for stepping. Set the time to reach up to 500kpps. Execution of stepping without setting this parameter will cause velocity/overvelocity undefined error (52) .
Jogging acceleration time	10 - 2000 (ms)	Set the acceleration/deceleration time for jogging. For function and setting, follow the above mentioned column, "Stepping acceleration time".
Origin return acceleration time	10 - 2000 (ms)	Set the acceleration/deceleration time for the origin returning. For functions and setting, follow the above mentioned column, "Stepping acceleration time".
Jogging direction	0 - 1	Set the direction for jogging. For details, refer to section 9.2 "Initial setting of NC parameter".
Origin returning direction	0 - 1	Set the origin returning direction. For details, refer to section 9.2 "Initial setting of NC parameter".
Pulse output direction setting	0 - 1	Set the coordinate direction of DMD*. For details, refer to section 9.2 "Initial setting of NC parameter"
Teaching travel amount setting	0 - 32767	Set the number of traveling pulses corresponding to one press of the jog-key, when the teaching of position data is executed with a front panel or a console.
S-shape acceleration/deceleration setting	0 - 10	Set the S-shape acceleration/deceleration. When 0 or 10 is set, the motor will move with linear acceleration/deceleration. For S-shape acceleration/deceleration, refer to section 9.7 "S-shape acceleration/deceleration function".
Input logic setting	0 - 8063	Input signal logic can be reversed. Refer to Fig. 7.1 "Input logic setting".

Option setting	0 - 123	<p>Set the special functions for the position driver. Contents to be set is described as below:</p> <ul style="list-style-type: none"> - Selection of position complete output (COIN) and decelerating output (DCLON) - Selection of the action after origin return complete - Selection of resetting method at emergency stop error (53) (Power supply reset, reset command) - Selection of positioning method (selection of active or inactive for present position overflow error) - Selection of control state at Servo-OFF entry - Selection of torque output at limit signal entry <p>For setting method, refer to Fig. 7.2 Option setting.</p> <p>For details refer to section 9.8.1 "Origin return offset function".</p> <p>For details refer to section 9.8.2 "Positioning method selection".</p> <p>For details refer to section 9.8.3 "Control state selection at servo-off".</p> <p>For details refer to section 9.8.4 "Torque output selection at limit signal input".</p> <p>This parameter becomes active after resetting the power supply.</p>
----------------	---------	--

(1) Input logic setting

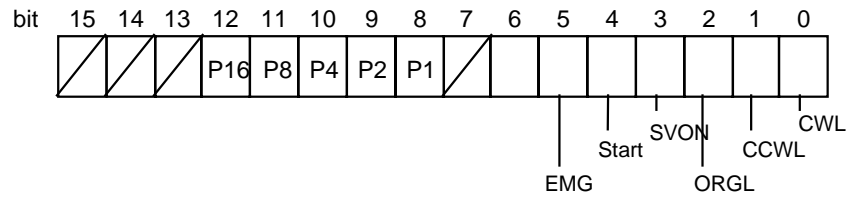

Fig. 7-1 Input logic setting

Setting example 1: For reversing EMG logic only set $2^5 = 32$

Setting example 2: For reversing EMG and CWL and CCWL logic set

$$2^5 + 2^1 + 2^0 = 32 + 2 + 1 = 35$$

(2) Option setting

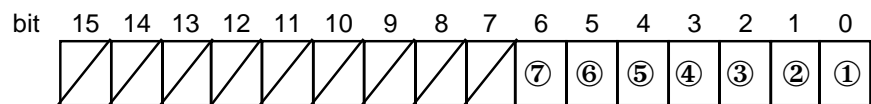

Fig. 7-2 Option setting

(1) Output signal selection

0: Deceleration output (DCLON)

1: Positioning finished signal (COIN)

(2) Operation selection after completing the origin return

0: Stops at the machine origin position

1: Automatically transfer to the offset position

(3) System use

This options must set to 0

(4) Reset method selection at emergency stop

0: Returns with power supply reset

1: Returns with power supply reset or with reset command

(5) Positioning method selection

0: Absolute transfer and relative transfer (Present position overflow error active)

1: Only relative transfer (Present position overflow error inactive)

(6) Control state selection at servo off

0: Becomes reset state at servo off

1: Holds the present state at servo off

(7) Torque output selection at limit input

0: Inhibit torque output in the limit input direction

1: Allow torque output in the limit input direction and inhibits pulse output only

Note 1) For input logic set the above contents in decimal number.

Note2) This parameter becomes active after resetting the power supply

Setting example: For use of COIN and return with reset command after emergency stop set

$$2^3 + 2^0 = 8 + 1 = 9 \quad \text{set 9!}$$

7.3 Details of Servo Parameters (User parameters)

No.	Parameter	Setting range	FunctionContents
00	Number of axis	0 - 31	<p>In multiple axis application, when personal computer is used, use this parameter for referring to or setting of parameter and monitoring the control state, and to which the computer is accessing. Also, it is used for ID indication on the front panel.</p> <p>When this parameter is "0," setting of rotary switch on the front panel becomes active.</p> <p>Setting value of this parameter does not affect any servo action.</p>
01	LED initial display	0 - 7	<p>Select the kind of data to be displayed on 7-segment LED at initial state such as power-ON among the followings;</p> <p>0: Displays the reserved pulse amount of position deviation counter. 1: Displays the motor speed with polarity. 2: Displays the motor torque with polarity. 3: Displays the driver ID No. 4: Displays the present position. 5: Displays the I/O state. 6: Displays the latest error contents . 7: Displays the parameter used by the manufacturer.</p> <p>For details of contents to be displayed, refer to section 10.3.1 "Monitor mode".</p> <p>Note1) If the polarity of figure data is „+“,“ +“ sign will not be displayed.</p> <p>Note2) If an error occurs at turning on the power supply, the error contents will be displayed with flashing, regardless of this parameter.</p>
03	Velocity loop gain	25 - 3500	<p>Proportional gain of velocity loop. Larger the setting value, larger the gain becomes.</p> <p>Optimum value for velocity loop gain differs depending on the load inertia and the model of the motor.</p>
04	Velocity loop integration time constant	1 - 1000	<p>Integration time constant of velocity amplifier. Smaller the setting value, faster the integration becomes.</p> <p>Note) If integration time constant is set to the maximum value (1000) of the setting range, integration time constant will be infinite (No integration).</p>
05	Velocity detection filter	0 - 4	<p>Select the kind (Time constant) of digital filter for velocity detection signal.</p>

06	Torque limit setting	0 - 300	<p>On the normal specifications of position driver, approx. three times of the rated torque is permitted as a peak torque. If there is a possibility that this 3 times torque generates a problem for intensity of the motor load (machine), the maximum torque can be limited by setting this parameter.</p> <p>For setting value, provide % value against the rated torque (100%).</p> <p>Ex.) If setting value is 200, 200% (2 times) of the rated torque is permitted.</p> <p>Note) This parameter cannot be set with value which exceeds the setting value with system parameter No. 06 (Maximum output torque setting) of factory setting. If the value which exceeds the maximum output torque setting value is set, it will be automatically corrected to the setting value of the maximum output torque.</p>
----	----------------------	---------	---

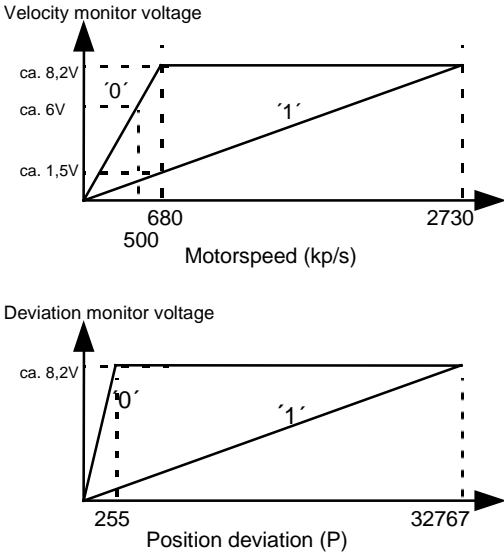
No	Parameter	Setting range	FunctionContents									
08	Velocity monitor gain selection	0 - 1	<p>Selects a full scale value of signal to be outputted to velocity monitor signal (CN I/F pin-16).</p> <table border="1" data-bbox="619 367 1313 481"> <thead> <tr> <th>Value</th> <th>Motorspeed</th> <th>Position deviation</th> </tr> </thead> <tbody> <tr> <td>0</td> <td>Approx. 680 (kpps)</td> <td>255p</td> </tr> <tr> <td>1</td> <td>Approx. 2730 (kpps)</td> <td>32767</td> </tr> </tbody> </table> <p>The following figure shows the relationship between motor speed/position deviation and monitor voltage.</p>  <p>The first graph, titled 'Velocity monitor voltage', shows two linear relationships. For setting '0', the voltage increases from approximately 1.5V at 500 kpps to approximately 8.2V at 680 kpps. For setting '1', the voltage increases from approximately 1.5V at 500 kpps to approximately 8.2V at 2730 kpps. The second graph, titled 'Deviation monitor voltage', shows two linear relationships. For setting '0', the voltage increases from approximately 1.5V at 255 position deviation to approximately 8.2V at 255 position deviation. For setting '1', the voltage increases from approximately 1.5V at 255 position deviation to approximately 8.2V at 32767 position deviation.</p> <p>For each monitor signal, select with parameter No. 3B.</p>	Value	Motorspeed	Position deviation	0	Approx. 680 (kpps)	255p	1	Approx. 2730 (kpps)	32767
Value	Motorspeed	Position deviation										
0	Approx. 680 (kpps)	255p										
1	Approx. 2730 (kpps)	32767										
09	Inactive run limit input	0 - 1	<p>By setting this parameter as "1," CW-run limit input (CWL)/CCW-run limit input (CCWL) will be ignored and operated, judging it as not in run limit input state.</p> <p>Note) If this parameter is set to "0" and CW-run limit input (CWL) is opened, the motor will not run to that direction. When the origin return is not completed, torque in that direction will not be generated, and hardware limit input error (55) occurs at the origin return completion. It is same when CCW-run limit input (CCWL) is opened.</p> <p>Also, if both CWL and CCWL are opened, the motor will stop by activating the protective function of the position driver as run inhibit input error.</p>									
10	Startup delay time	0 - 600	<p>Set the startup time of the position driver.</p> <p>If the startup of external 24V power supply is slower than that of the position driver, use this parameter to delay the startup time of the position driver.</p> <p style="text-align: right;">Unit: (100ms.)</p>									

No.	Parameter	Setting range	FunctionContents
20	Position loop gain	0 - 1000	<p>Sets position gain. Unit of the setting value is (1/S).</p> <p>Larger the setting value, larger the position gain and the servo stiffness (Typical hardness at servo locking) increases.</p> <p>Note) Note that too large setting may cause an oscillation.</p>
21	Velocity feed forward	0 - 100	<p>If high speed response is especially necessary, velocity feed forward function can be added with this position driver.</p> <p>With this parameter, set the feed forward volume in the rate (%) against the command volume.</p> <p>Note) If the velocity feed forward volume is set excessively, unstable situation will be increased and oscillation will be generated. It is recommend to set this parameter to "0" unless you especially high speed response is required. If this parameter is set other than "0," set parameter 2B "Feed forward filter time constant" to 200 or more.</p>
22	Positioning complete range	0 - 32766	<p>Sets the detection level for judging the positioning complete with the number of pulse.</p> <p>The driver judges the positioning complete when the number of reserved pulse for the deviation counter becomes within (setting value), and outputs (Output transistor is ON.) the positioning complete signal (COIN).</p> <p>Note) As the feed back pulse of the rotary encoder is multiplied by 4 times, and enters to the deviation counter, the positioning complete range is converted into the motor rotation angle as follows:</p> $\text{Setting value} = \frac{\text{Positioning complete range}}{\text{Pulse number of rotary encoder}}$
23	Excessive position deviation setting	1 - 32766	<p>Sets the detection level for judging the excess position deviation with the number of the reserved pulse in the deviation counter.</p> <p>Calculate the setting value with the following formula.</p> $\text{Setting value} = \frac{\text{Judging level of excess position deviation (pulse)}}{16}$ <p>When the number of reserved pulse for the deviation counter exceeds the judgment level indicated with the above setting value, the driver judges the error to activate the protective function and stops the motor.</p>
24	Inactivation of excessive position deviation setting	0 - 1	<p>Inactivates the protective function of the excessive position deviation error.</p> <p>By setting this parameter to "1," detection of the excessive position deviation error will be stopped and the operation will be continued even with exceeding deviation counter, not taking it as error condition.</p>
2A	Torque filter (time constant)	0 - 2500	<p>Sets time constant of the torque filter.</p> <p>Larger the setting, larger the time constant becomes.</p> <p>Set parameter 05 "Velocity detection filter" to 0, when changing this parameter.</p> <p style="text-align: right;">Unit: (10s)</p>

2B	Feed forward filter time constant	0 - 6400	<p>Sets time constant of the feed forward filter.</p> <p>If parameter 21 "Velocity feed forward" is set to other than "0," set this parameter to 200 or larger.</p> <p>Larger the setting , larger the time constant becomes.</p> <p style="text-align: right;">Unit: (10s)</p>
30	2 nd .volocity loop gain	25 - 3500	<p>Proportional gain of velocity loop. Larger the setting value, larger the gain becomes.</p> <p>Optimum value of the velocity loop gain differs depending on the load inertia and the motor model.</p> <p>Changeover setting to 2nd. gain to be made with parameter No. 33, „2nd. gain action setting“.</p>

No.	Parameter	Setting range	FunctionContents
31	2 nd . velocity loop integration time constant	1 - 1000	<p>Integration time constant of velocity amplifier. Smaller the setting, faster the integration.</p> <p>Note) If integration time constant is set to the maximum value (1000) of the setting range, it becomes infinite (No integration).</p> <p>Changeover setting to 2nd. gain is to be made with parameter No. 33, „2nd. gain action setting“.</p>
32	2 nd . position loop gain	0 - 1000	<p>Sets the position gain. Unit of the setting value is (1/s).</p> <p>Larger the setting value, larger the position gain becomes, and higher the servo stiffness (Typical hardness at servo locking).</p> <p>Note) Note that too large setting may cause an oscillation. changeover setting to 2nd. gain is to be made with parameter No. 33, „2nd. gain action setting“.</p>
33	2 nd . gain action setting	0 - 1	<p>Sets the changeover mode to 2nd. gain setting for parameter No. 30-32.</p> <p>0: No changeover to 2nd. gain. 1: Automatic changeover to 2nd. gain.</p>
34	2 nd . gain changeover delay time	0 - 10000	<p>Sets the delay time for changeover to 2nd. gain when parameter No. 33 is set to “1”. Time to be the delay time after completing the command pulse generation.</p> <p style="text-align: right;">Unit: (2.0 ms)</p>
	Excessive position deviation setting at Servo-Off		<ul style="list-style-type: none"> □ Set a detection level for excessive position deviation judgment at Servo-Off, with reserved pulses in deviation counter. □ Setting value can be calculated with the following formula; $\text{Setting value} = \frac{\text{excessive position deviation judgment level(pulses)}}{16}$ <p>When the reserved pulses in the deviation counter</p> <ul style="list-style-type: none"> □ exceeds the above preset judgment level while the Servo-On signal input is turned on. The position driver judges this as an error to activate the protective function, and stops motor. <p>This setting becomes active when parameter 3E, „Sequence at Servo-Off“ is set to 4 - 7(retains the deviation counter at Servo-Off).</p>
3B	Velocity monitor signal selection	0 - 1	<p>Selects a signal to be outputted to velocity monitor signal (CN I/F 16 pin).</p> <p>0: Motor speed 1: Position deviation</p> <p>For scale of each monitor, select with parameter No. 08.</p>

3D	Sequence at alarm	0 - 3	<p>Sets the control pattern to stop the motor when an alarm occurs.</p> <table border="1" data-bbox="643 241 1323 427"> <thead> <tr> <th>Value</th> <th>At deceleration</th> <th>After stopping</th> </tr> </thead> <tbody> <tr> <td>0</td> <td>DB ON</td> <td>DB ON</td> </tr> <tr> <td>1</td> <td>Freerun</td> <td>DB ON</td> </tr> <tr> <td>2</td> <td>DB ON</td> <td>Freerun</td> </tr> <tr> <td>3</td> <td>Freerun</td> <td>Frerun</td> </tr> </tbody> </table> <p>DB: Dynamic brake</p>	Value	At deceleration	After stopping	0	DB ON	DB ON	1	Freerun	DB ON	2	DB ON	Freerun	3	Freerun	Frerun																					
Value	At deceleration	After stopping																																					
0	DB ON	DB ON																																					
1	Freerun	DB ON																																					
2	DB ON	Freerun																																					
3	Freerun	Frerun																																					
3E	Sequence at servo-off	0 – 7	<p>Sets the action pattern at servo-off.</p> <table border="1" data-bbox="635 593 1264 952"> <thead> <tr> <th>Value</th> <th>At deceleration</th> <th>After stopping</th> <th>Deviation counter</th> </tr> </thead> <tbody> <tr> <td>0</td> <td>DB ON</td> <td>DB ON</td> <td>Clear</td> </tr> <tr> <td>1</td> <td>Freerun</td> <td>DB ON</td> <td>Clear</td> </tr> <tr> <td>2</td> <td>DB ON</td> <td>Freerun</td> <td>Clear</td> </tr> <tr> <td>3</td> <td>Freerun</td> <td>Freerun</td> <td>Clear</td> </tr> <tr> <td>4</td> <td>DB ON</td> <td>DB ON</td> <td>hold</td> </tr> <tr> <td>5</td> <td>Freerun</td> <td>DB ON</td> <td>hold</td> </tr> <tr> <td>6</td> <td>DB ON</td> <td>Freerun</td> <td>hold</td> </tr> <tr> <td>7</td> <td>Freerun</td> <td>Freerun</td> <td>hold</td> </tr> </tbody> </table> <p>DB: Dynamic brake</p>	Value	At deceleration	After stopping	Deviation counter	0	DB ON	DB ON	Clear	1	Freerun	DB ON	Clear	2	DB ON	Freerun	Clear	3	Freerun	Freerun	Clear	4	DB ON	DB ON	hold	5	Freerun	DB ON	hold	6	DB ON	Freerun	hold	7	Freerun	Freerun	hold
Value	At deceleration	After stopping	Deviation counter																																				
0	DB ON	DB ON	Clear																																				
1	Freerun	DB ON	Clear																																				
2	DB ON	Freerun	Clear																																				
3	Freerun	Freerun	Clear																																				
4	DB ON	DB ON	hold																																				
5	Freerun	DB ON	hold																																				
6	DB ON	Freerun	hold																																				
7	Freerun	Freerun	hold																																				

8 Communication function

DMD* Series position driver has a function of performing serial communication with personal computers via RS-232C. With this function, a personal computer can be used as a console. By using a personal computer as a console, various parameters of the position driver and monitoring of the control state can be conducted by using a monitor on the personal computer.



Caution

It is strictly necessary to use the „American Standard Scriptdriver“ (ANSI.SYS). Otherwise your lines will get out of place.

Enter the ansi.sys into the Config.sys of your Computer.

Normally, it is enough to enter the following line:

- „DEVICE=C:\WINDOWS\COMMAND\ANSI.SYS“

8.1 Construction units and software

8.1.1. Construction units

(1) Corresponding hardware
Operation by the following units is confirmed with automatic machine type recognition in the software.

- a) IBM PC/AT or their compatible machines
- b) DOS/V machine
- c) NEC personal computers, PC-98 series or their compatible machines

Ex.) PC-9801NS/RNS/TNA/CNA, etc.

(2) Corresponding OS

It is confirmed by the following versions of OS which corresponds to the above hardware.

- a) IBM PC/AT machine
MS-DOS 6.2 (J)
- b) DOS/V machine
MS-DOS6.2/V
- c) In case of using PC98 series
Prepare MS-DOS ver. 3.0 or upper by customers.
Incorporate RS-232C control file "RSDRV. SYS" into MS-DOS as the device driver.

Note) When using hardware or OS other than the above, check for it by customers.

8.1.2. Software for communication control (MINITERM)

Prepare MINITERM (option) for DMD*.

For the operation method, refer to "MINITERM Instruction Manual" attached to MINITERM.

As an option, a cable to connect connector for position driver front panel section with connector for RS-232C of personal computer is prepared.

You can take the Indramat cable IKS 0199 Part – No 281 538

9 Operation

9.1 Summary of Functions

The position driver performs communication with sequencer I/O by using I/O of connector I/F for executing positioning, origin return action, etc.

Action command will be assigned by using point assign input (P1IN-P16IN) signal. For the relationship of the point assign input and the operation command, refer to the following table. For executing the command, command type is determined by P1IN - P16IN and then strobe signal is input.

Point No.	P16IN	P8IN	P4IN	P2IN	P1IN	Contents
0 (00H)	H	H	H	H	H	Reset command
1 (01H)	H	H	H	H	L	Shift to step data 1
2 (02H)	H	H	H	L	H	Shift to step data 2
3 (03H)	H	H	H	L	L	Shift to step data 3
4 (04H)	H	H	L	H	H	Shift to step data 4
5 (05H)	H	H	L	H	L	Shift to step data 5
6 (06H)	H	H	L	L	H	Shift to step data 6
7 (07H)	H	H	L	L	L	Shift to step data 7
8 (08H)	H	L	H	H	H	Shift to step data 8
9 (09H)	H	L	H	H	L	Shift to step data 9
10 (0AH)	H	L	H	L	H	Shift to step data 10
27 (1BH)	L	L	H	L	L	Shift to step data 27
28 (1CH)	L	L	L	H	H	Shift to step data 28
29 (1DH)	L	L	L	H	L	High-speed jogging (-direction)*
30 (1EH)	L	L	L	L	H	High-speed jogging (+direction)*
31 (1FH)	L	L	L	L	L	Origin return command

H indicates contact open state (0), and L indicates contact closed state (1).

*Jogging direction can be reversed with parameter.

Setting example) If P8IN, P1IN signals are in contact point close state (1), and other signals are in contact point open state:

$$2^3 + 2^0 = 8+1 = 9, \text{ indicating point 9 (09H).}$$

9.2 Initial setting of NC parameter

Before setting various parameters and operations, conduct the following settings:

- (1) Setting of DMD* coordinate system
Decide which side of the motor shaft rotation to be defined as + direction. The coordinate system used by DMD* is set by the parameter "Pulse output direction setting."
By setting this parameter to 0, + direction is defined as CCW and - direction is defined as CW. By setting this to 1, + direction is defined as CW and - direction is defined as CCW.
Since this parameter becomes active after resetting the power supply and reset the power supply once after setting this parameter.
- (2) Setting of jogging direction
Jogging direction is set by the parameter "Jogging direction."

With parameter 0, key operation makes + direction jogging, and key operation makes -direction.

With parameter 1, key operation makes + direction jogging, and key operation makes - direction.

Set jog acceleration/velocity, and confirm that jogging directions are correct by using a console or I/O.
- (3) Setting of origin returning direction
Origin return direction is set by parameter "Origin returning direction."
By setting this parameter to 0, origin returning is performed in + direction, and by setting to 1, origin returning is performed in - direction. (Indicating the direction to which the origin vicinity sensor rushes in the end.)
Set acceleration/speed of the origin return, and confirm that origin returning direction and origin return position are correct.
- (4) Setting and confirmation of stepping
After confirming that the above settings are all correct, enter the stepping data and check the stepping after setting acceleration/velocity.

9.3 Position driver state transition

Executable command types of this driver are different based on the following three control states.

Reset state (when the present position is not decided at power-ON)

Normal state (when the present position is retained after completing the origin return.)

Alarm state (when alarm occurs and protective function of the position driver is activated.)

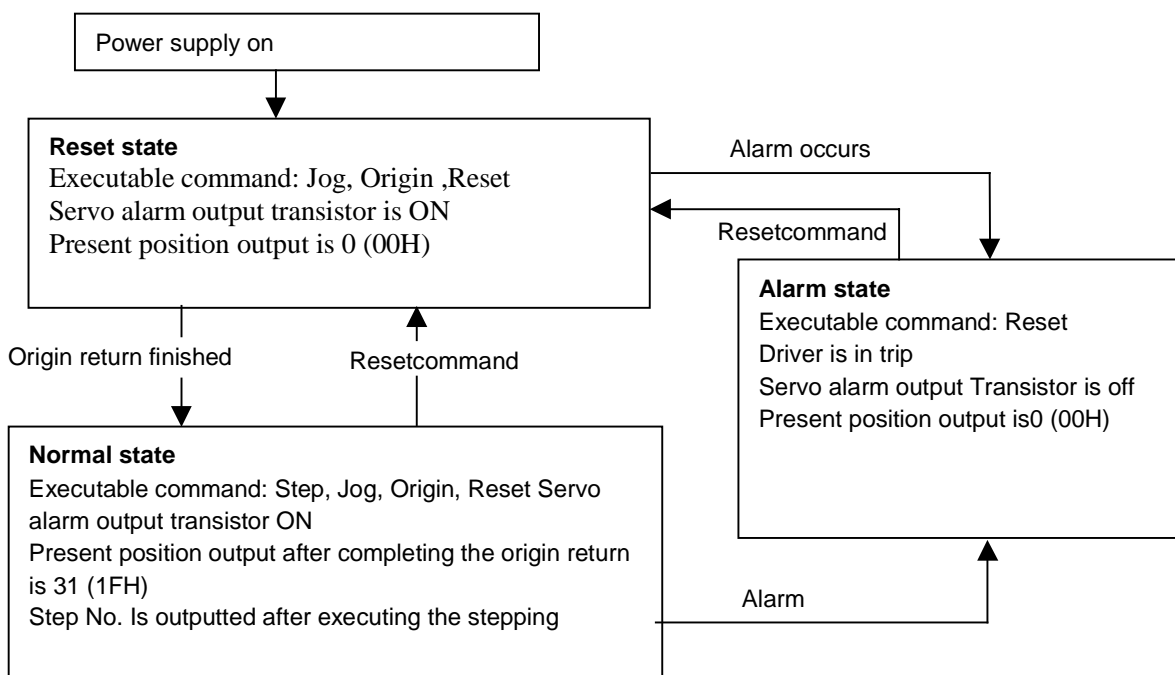

Fig. 9-1 Position driver state transition

9.4 Sequence at power-ON

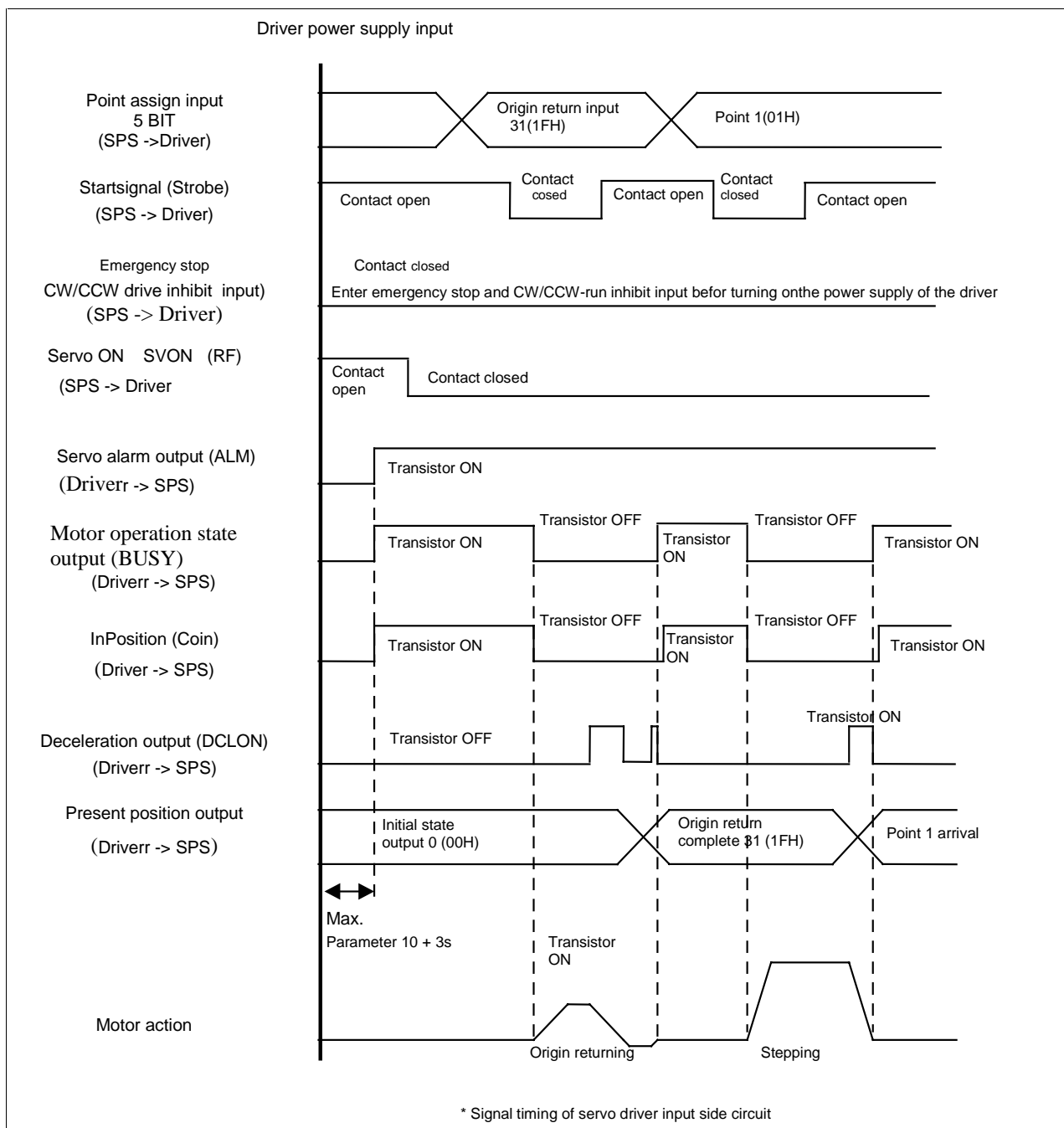

Fig. 9-2 Sequence at power-ON

Note) Time between the startup of the position driver and power-ON can be adjusted with servo parameter No. 10 "Startup delay time." (Refer to section 7.3 "Details of servo parameters (User parameter)")

9.4.1. Electromagnetic brake release timing

When the motor with electromagnetic brake for Z-axis elevating (vertical) operation, etc., is used, release the brake with the following timing (=power-ON).

- (1) In case that Servo-ON signal input is ON before the power-ON of the position driver

Allow „Startup delay time“ (of parameter No. 10) + 3 seconds before releasing the brake after the power-ON of the driver, and confirm no alarm occurs.

Enter a strobe signal (STB) 500ms or longer after the brake release.

- (2) In case that Servo-On signal input is ON after the power-ON of the position driver

Allow 1 second or longer before releasing the brake after turning on the servo-on signal input at the power-ON(no alarm).

Enter a strobe signal (STB) 500ms or longer after the brake release.

9.5 Action specifications

9.5.1. Step command

- (1) Position travels to the point assigned by P11N - P16 IN. Information for the travel must be described in step data. If it travels to an unregistered step, step data non-definition error (54) occurs and the protective function is activated to stop the motor.
- (2) Use the reference velocity data registered in velocity data, for action velocity. If non-registered typical velocity is referred, or acceleration is not defined, velocity/acceleration non-definition error(52) occurs, and the protective function is activated to stop the motor.
- (3) If the origin return is incomplete command at power-ON, the step command will not be executed even if it is entered.
- (4) If the limit signal of the same running direction is entered while the step command is in execution, hardware limit input error(55) occurs, and the protective function is activated to stop the motor.
- (5) When the position exceeds the software limit range while the step command is in execution, software limit input error(56) occurs, and the protective function is activated to stop the motor.
- (6) If the relative travel continues to the same direction, the present position overflows. If the present position exceeds the range of -1073741824 - 1073741823, present position overflow error (57) occurs, and the protective function is activated to stop the motor. Check the setting contents of the step data and the program contents of the host controller.
When „Relative travel use only“ is selected for positioning method with optional setting of NC parameter, present position overflow error will occur. However, the step command will be only for relative travel. (For details, refer to section 9.8.2 "Positioning method selection")
- (7) When an error occurs in the position driver, enter the reset command and execute the origin return command, in order to execute step command.

9.5.2. Jog command

- (1) Jog command continues its action while a strobe signal is being entered (contact closed).
- (2) In case of jogging with I/O, low-speed jogging which is assigned by reference velocity data cannot be to be executed.(this is only possible by a console).
- (3) Jogging direction can be reversed with parameter.
- (4) If the limit signal of the same running direction is entered during a jogging at reset state, the motor only stops, however, if the limit signal is entered during a jogging at normal state after the origin return complete, hardware limit input error(55) occurs, and the protective function is activated to stop the motor.
- (5) If the motor position exceeds the software limit range during a jogging, software limit error (56) occurs, and the protective function is activated to stop the motor.
- (5) If a jogging continues to the same direction, the present position overflows. When the present position exceeds the range of -1073741824 - 1073741823, present position overflow error (57) occurs, and the protective function is activated to stop the motor. When „Relative travel use only“ is selected for positioning method with optional setting of NC parameter, the present position overflow error will not occur.
(For details, refer to section 9.8.2 "Positioning method selection")

9.5.3. Origin return command

- (1) Action specification of the origin return is shown in Fig. 9.3 Origin returning specification.
- (2) If the error limit signal is entered during execution of the origin return command, Origin return error (51) occurs, and the protective function is activated to stop the motor.
- (3) Origin offset can be set by a parameter. For details, refer to section 9.8.1 "Origin return offset function".
- (4) Wire so as the origin vicinity input is connected to COM-, 180 degrees before Z-phase.
- (5) If the origin returning is executed at very close position to the origin return sensor, the motor may rotate max. 1 revolution when detecting the start-down of the origin sensor(the last transition of the origin sensor).

9.5.4. Reset command

- (1) Reset command is used to return the position driver to the initial state (reset state) when an alarm of the position drive occurs. (Active without generating an alarm).
- (2) If the reset command is executed, the position driver returns to the state found after the power supply is turned on.
- (3) By executing the origin return command, step command becomes active.

9.5.5. Emergency stop input

- (1) When an emergency stop input is entered, emergency stop input error (53) occurs, and the protective function is activated to stop the motor.
- (2) Emergency stop input error can be reset by turning the power supply on again under the initial state. This can be reset from the emergency stop error by setting the option of NC parameter. (For the setting method, refer to section 7.2.4 "NC data".)

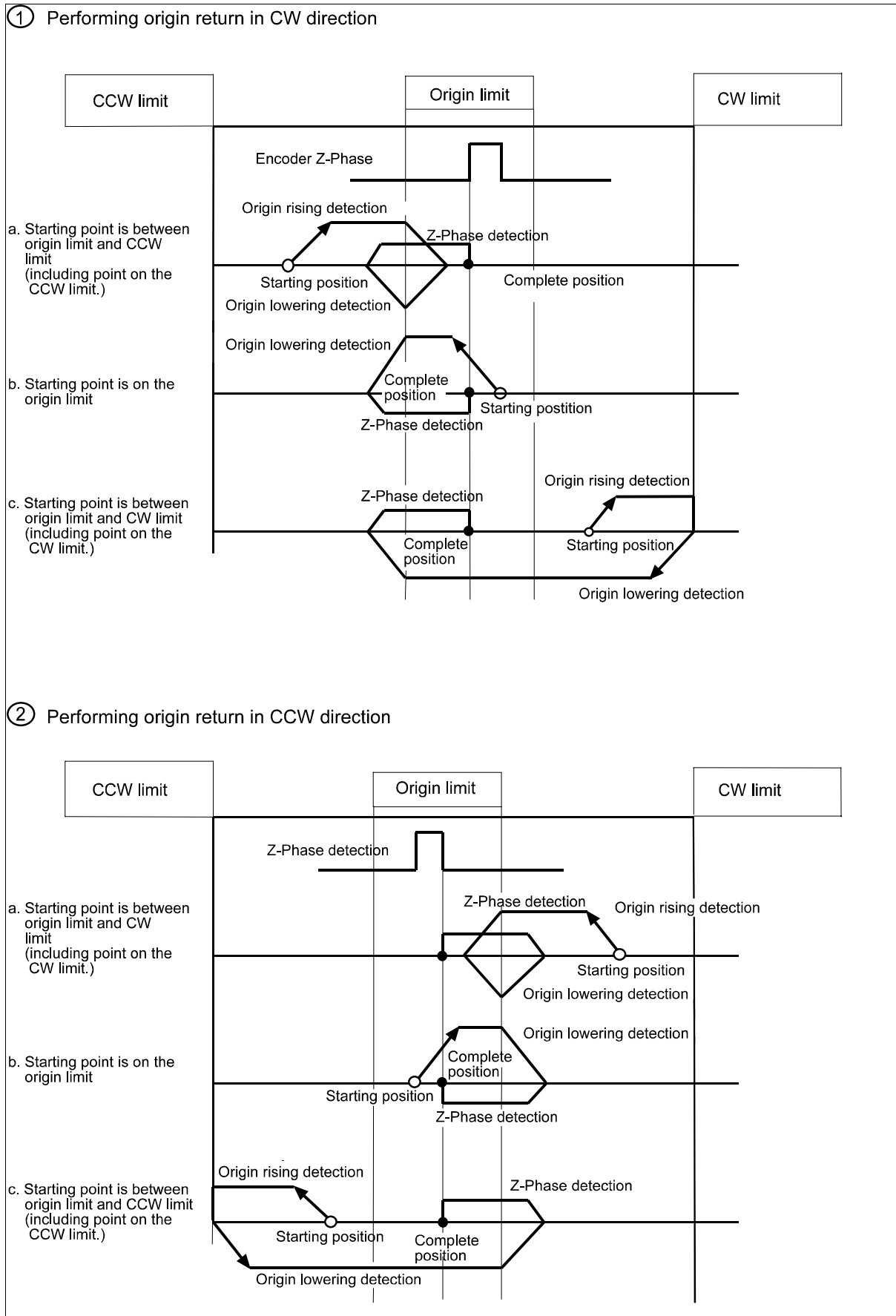

Fig. 9-3 Origin return action specification

9.6 Interface timing

The timing chart shown below is the one viewed from the position driver side and a console is not used. This timing chart is not applicable a console is used. Allow several ms of margin for the timing between the position driver and I/O.

9.6.1. Step command, origin return command

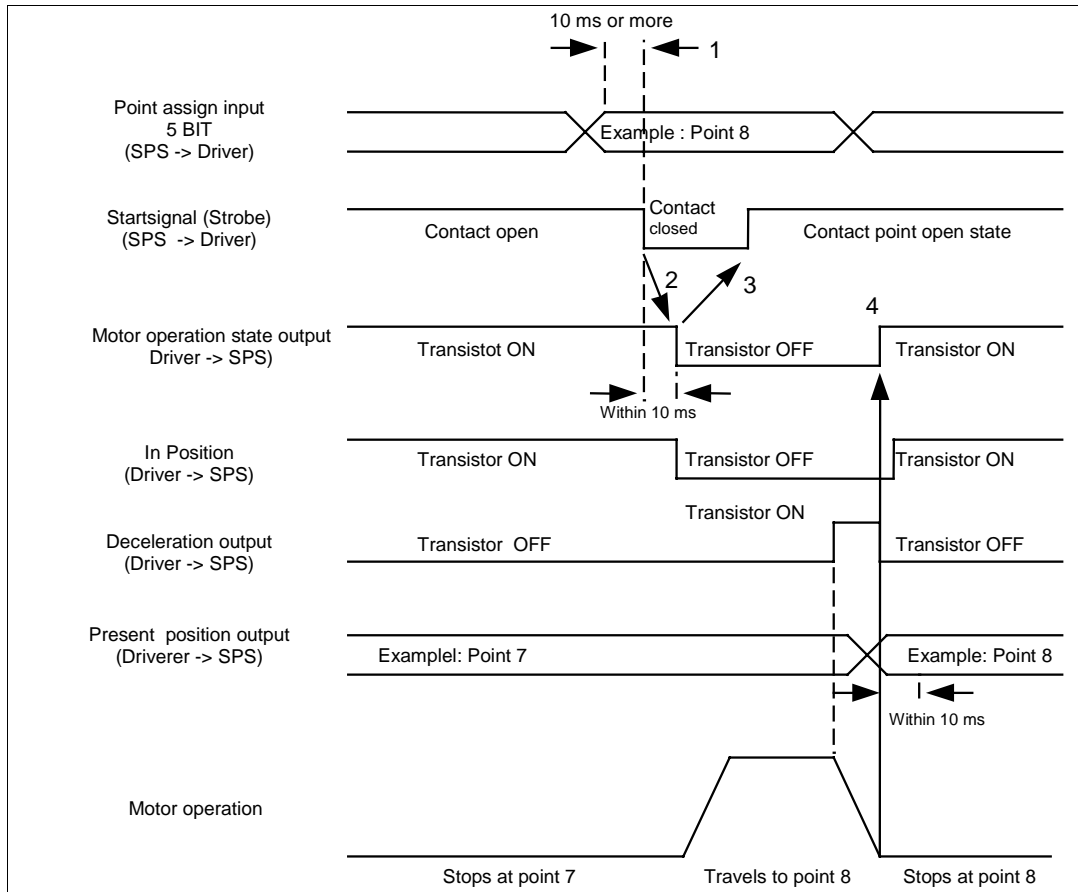

Fig. 9-4 Interface timing (In stepping)

- (1) Assign the next travel point from the point assign input signal (P11N-P16N) with the sequencer I/O (P11N - P16IN) (E.g. Point 8).
- (2) After entering the point assign, allow more than 10ms. Before making the strobe signal input (STB) from open to closed to COM-. By executing this operation, action command will be entered to the position driver.
- (3) When the action command is entered to the position driver, transistor for motor-running output (BUSY) is turned OFF within 10ms., and the motor starts running. After the motor-running output transistor is turned OFF, make the strobe signal open.
- (4) During the motor deceleration, the transistor of decelerating output (DCLON) is turned ON.

- (5) After the completion of the motor action, motor-running output transistor is returned to ON state. Present position output signal (P1OUT -P16OUT) outputs 8 (08H) within 10ms. The transistor of the positioning complete state output (COIN) will be turned on when the reserved pulse of the deviation counter becomes within "Positioning complete range" of parameter No.22.

Note1) With regard to positioning complete state output (COIN) and decelerating output (DCLON), decide which signal to be used with the option setting for NC parameter. (Refer to section 7.2.4 "NC data")

Note2) If the motor action is completed while the strobe signal input is not returned to the open state after the motor-running output is turned OFF, motor-running output transistor is kept OFF without returning to ON. Return the strobe signal to open, after the motor-running output transistor is turned OFF.

9.6.2. Jog command

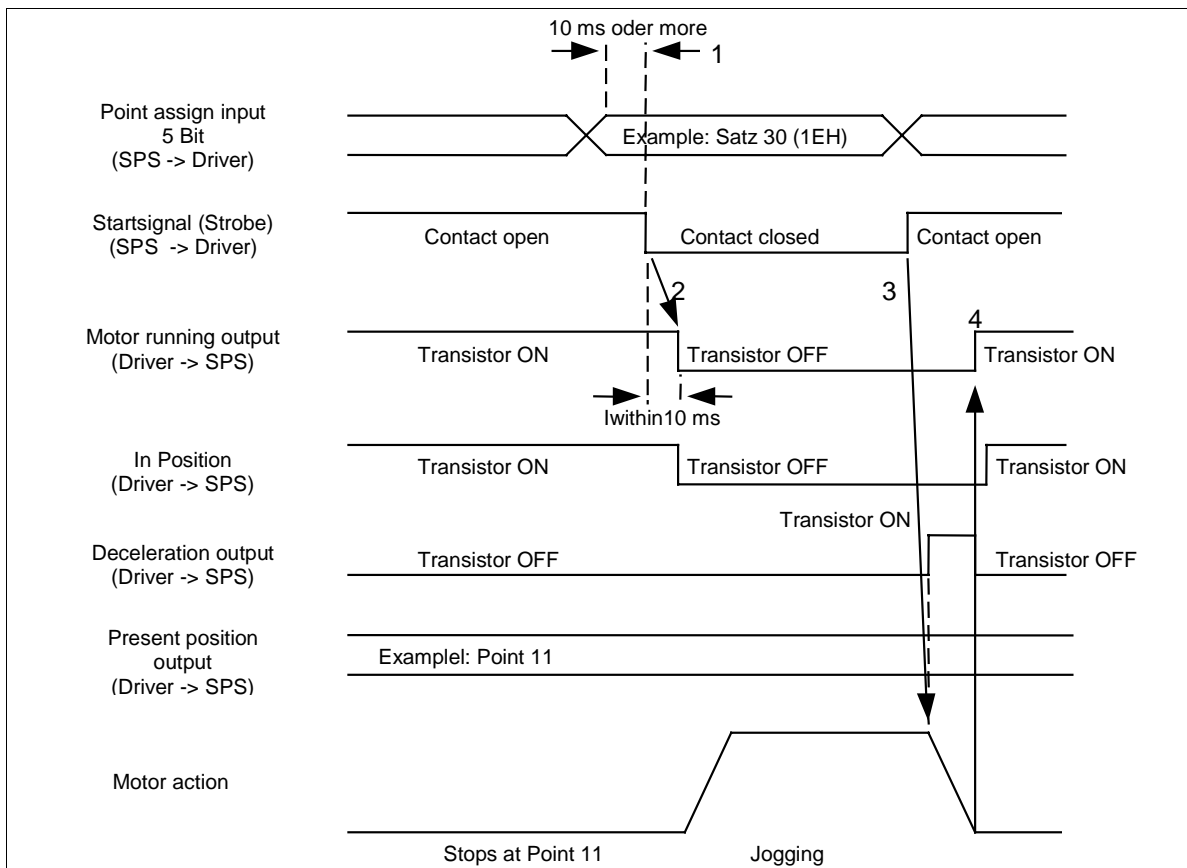

Fig. 9-5 Interface timing (In jogging)

- (1) Assign a jog command from the point assign input signal (P1IN-P16IN) with I/O of the sequencer. (point 29 or point 30).
- (2) Make the strobe signal input (STB) connecting state with COM- from open, 10ms. or more after entering point assign. With this operation, jogging command is entered to the position driver.
- (3) Motor-running output transistor (BUSY) is turned OFF within 10ms. after action command is entered to the position driver, and the motor starts jogging.
- (4) Jogging decelerates to stop by returning the strobe input signal to open.
- (5) During the motor deceleration, the transistor of decelerating output (DCLON) is turned ON.
- (6) When the motor completes its action, motor-running output transistor is returned to the ON. Present position output signal (P1OUT - P16OUT) does not change. The transistor of the positioning complete output (COIN) is turned on when the reserved pulse amount in the deviation counter becomes within "Positioning complete range" of parameter No.22.

Note 1) With regard to positioning finish state output (COIN) and decelerating output (DCLON), decide which signal to be used with the option setting for NC parameter.
(Refer to section 7.2.4 "NC data")

9.6.3. Reset command

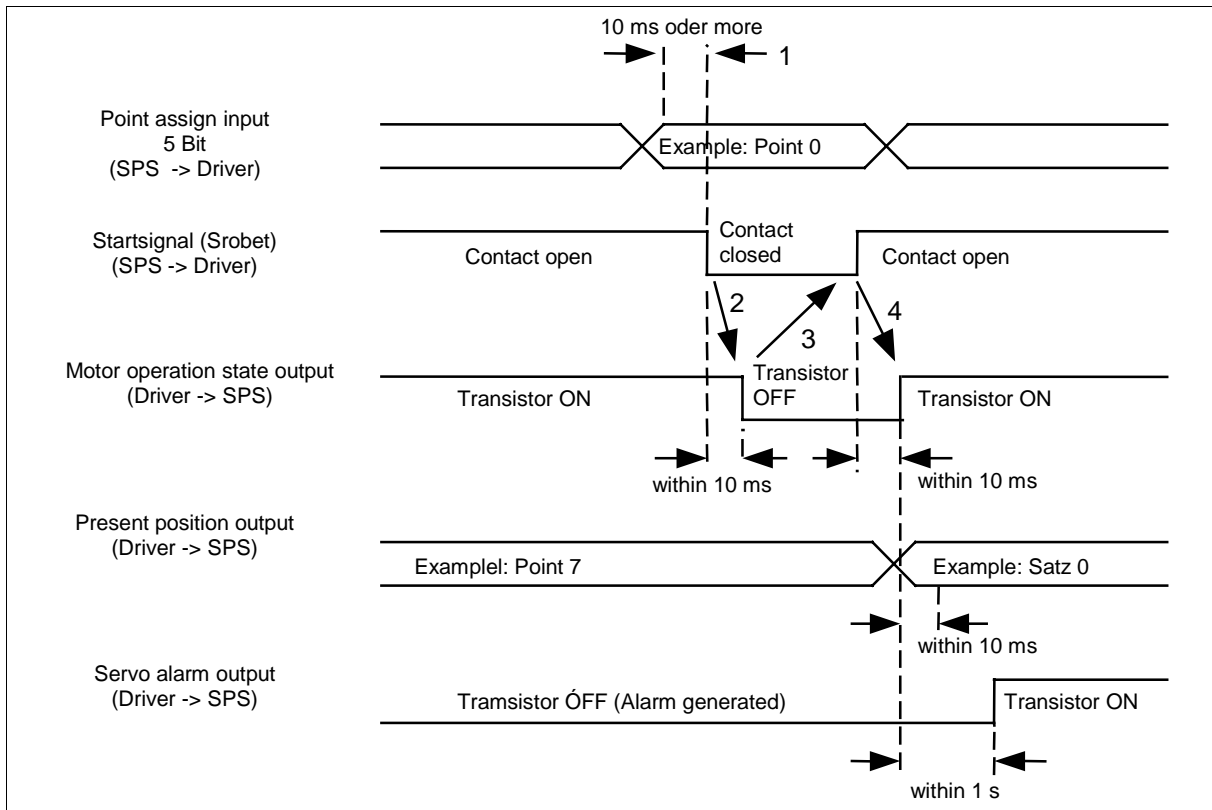

Fig. 9-6 Interface timing (With reset command)

- (1) Assign a reset command (Point 0) from a point assign input signal (P1IN - P16IN) with I/O of the sequencer.
- (2) Make a strobe signal input (STB) to connecting state with COM- from open, 10ms or more after entering point assign. With this operation, reset command is entered to the position driver.
- (3) Motor-running output transistor (BUSY) is turned OFF within 10ms. After action command is entered to the position driver. Return the strobe input signal (STB) to open, after the motor-running output transistor is turned OFF, then the reset command will be executed.

- (4) Since the reset command is executed instantaneously, if the strobe input signal is returned to open, motor-running output transistor will be returned ON.
If no alarm occurs, present position output signal (P1OUT - P16OUT) will be turned to 0 (00H: All transistors are OFF.) within 10ms. If an alarm is cleared normally when the alarm occurs, servo alarm output (ALM) transistor will be turned on within 1 second.

Note) This reset command is a command for returning the position driver to the initial state (Reset state) when an alarm occurs to the position driver (Alarm clear).

9.7 S-shape acceleration/deceleration function

With this position driver, S-shape acceleration/deceleration is possible at acceleration and deceleration.

Set the S-shape acceleration/deceleration with NC parameter "S-shape acceleration/deceleration setting."

By changing value of this parameter, turning point of S-shape acceleration can be changed.

The smaller the value, the more rapid the acceleration becomes, and the larger the value, the more rapid the deceleration becomes (When it is 0 or 10, it will be linear acceleration/deceleration control).

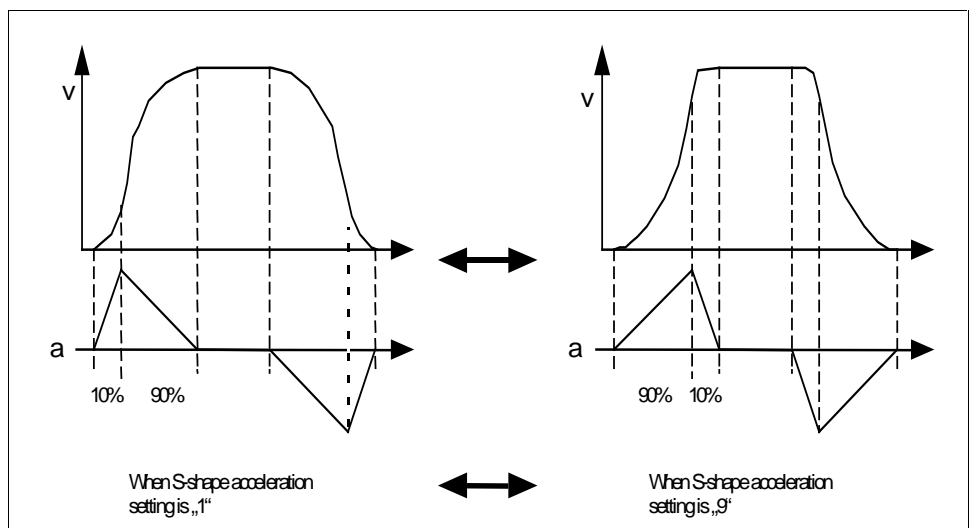
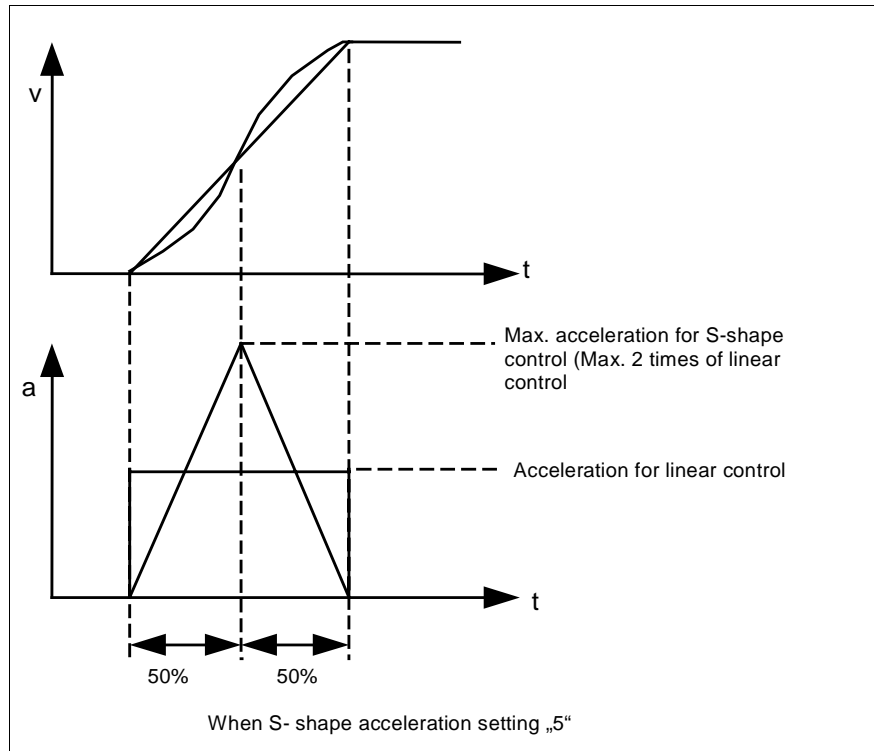

- Note1) In normal case, set the S-shape accel./deceleration setting parameter to "5."
- Note2) S-shape accel./deceleration on this position driver is controlled against the preset acceleration time with S-shape. Therefore, the acceleration time is different from the that for linear accel./deceleration, and the maximum acceleration at S-shape accel./deceleration becomes maximum 2 times of the linear accel./deceleration with the same setting, and the acceleration torque may become insufficient.
- Note3) Positioning time in S-shape accel./deceleration is longer than that of linear accel./deceleration.
- Note4) S-shape accel./deceleration can be applied only to acceleration at step command and jog command.
- Note5) If the acceleration is moderate and the travel distance is short, it may not reach to the maximum velocity.

9.8 Special function

9.8.1. Origin return offset function

Assign the origin return offset function with pulse amount from the machine origin (position of the first Z-phase after detecting the origin vicinity sensor).

When executing the origin return command, action after stopping at the machine origin position can be set with an option setting for NC parameter. For setting method, refer to section 7.2.4 "NC data".

If the action selection at origin return completion is set to "0," the motor stops at the machine origin position, and present position becomes to (-origin offset amount). When travel to the origin offset position is required, it is necessary to travel to the absolute position 0 with the step command.

If the action selection at origin return completion is set to "1," the motor travels to the origin offset position with the minimum velocity (5kpps) after stopping at the machine origin position. The present position after origin return completion becomes "0."

Since the origin return offset parameter becomes active after the reset, reset the power supply once after setting this parameter.

When origin offset amount is set to -5000

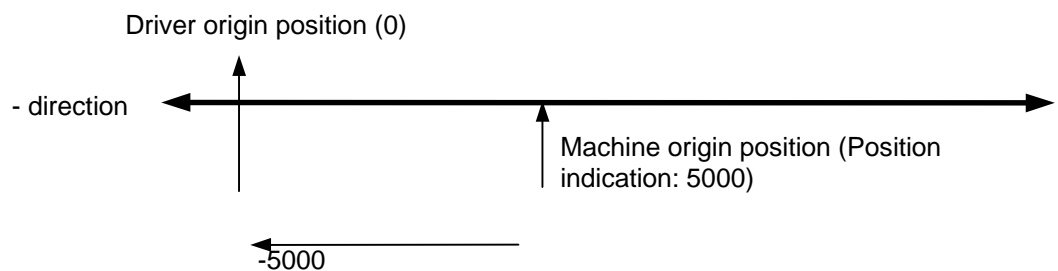

Fig. 9-7 Offset setting example

9.8.2. Positioning method selection

With NC parameter option setting, positioning method of this position driver can be selected. (For setting method, refer to section 7.2.4 "NC data").

If "Absolute action/Relative action use" is selected as a positioning method, absolute position action (ABS) and relative position action (INC) can be executed with a step command. However, if relative travel continues to the same direction, the present position will overflow. If the present position exceeds the range of -1073741824-1073741823, present position overflow error (57) occurs, and protective function of the position driver will be activated to stop the motor.

If the positioning at the absolute position is required in the system where action range is decided, it is necessary to select "Absolute action/Relative action" for the positioning method.

If "Relative action use only" is selected as the positioning method, only a relative action can be executed. In this case, present position overflow error will not occur even if the present position overflows. (Present position overflow error becomes inactive).

It is required to select „Relative action use only“ as a positioning method, in the system where the positioning action keeps continuously to the same direction.

9.8.3. Control state selection at servo-off

Control state at servo-off of this position driver can be selected with option setting of NC parameter. (For setting method of parameter, refer to section 7.2.4 "NC data").

While "Normally reset state at the servo-off" (0) (Initial setting state) is set, and if servo-ON signal is turned OFF at normal state (when origin return is completed), the position driver will shift to reset state (no origin return is executed)..

To execute a stepping by turning to servo-ON after making servo-off, re-execute origin return action.

If "Retain the present state at the servo-off" (1) is set, control state at servo-on (normal state) can be retained even with servo-off.

In this case, set the servo parameter 1E, "Sequence at servo-off" to "Deviation counter".

By executing this setting, the motor acts by deviation counter amount at re-servo-on, since the deviation counter will be retained, then the motor tries to travel back to the position at servo-on state.

Pay attention for safety, as the motor travels by deviation counter amount at servo-off state.

If the deviation counter amount at servo-off is too large, overcurrent error, overload error, deviation counter error, etc. may occur as the motor acts rapidly. In such case, do not use this function.

9.8.4. Torque output selection at limit signal input

With NC parameter option setting, operation method at the limit signal input can be selected. (For setting method, refer to section 7.2.4 "NC data").

If "Torque output limit to limit signal input direction" (0) (initial setting state) is set, torque to this direction will not generated when the limit signal turns to open.

If "Torque output permit to limit signal input direction" (1) is set, it will turn to servo-lock state when the limit signal turns to open. Torque in this direction will generated, but no action will made.

Note) The above setting becomes active only when the origin return is not completed (Reset).

If the limit signal to the acting direction is opened (while at run-limit state) at origin return completion (normal state), hardware limit error (55) occurs and the position driver will trip.

Use this function only at adjustment. Even if the limit signal is opened, torque will be kept generating. Pay enough attention for the safety.

10 Key operation on the front panel

10.1 Description of each key

Key	Name of key	Function of key
[MODE]	MODE key	Used for mode changeover
[SET]	SET key	Used for changeover of selection display state and execution display state.
↑↓	CURSOR key	Used for change of data / selection of parameter while the decimal point is flashing. Used for teaching to coordinate data input.. when entering step data (Only at return origin completion)
←	SHIFT key	Used for shifting to upper digit of the changed data digit, while the decimal point is flashing. Used for canceling the entered data, at step data entry Used for execution of test run, at test run

10.2 Summary of operation

In case of operating with key switches on the front panel section or LED, there are 9 kinds of modes: monitor mode, step data edit mode, velocity data edit mode, NC data edit mode, offset data edit mode, servo parameter edit mode, EEPROM write-in mode, automatic gain tuning mode, and test run mode.

Use the [MODE] for changeover of these modes.

Selection display and execution display are provided for each mode, use the [SET] switch for changeover of these two displays. Use 3 key switches of [↑] [↓], or [←] for selection and execution at each mode.

In the display, data change is possible to the digit where decimal point is flashing. When there is no flashing decimal point, these [↑], [↓] and [←] keys are inactive.

At power ON, the contents selected with servo parameter No. 01"LED initial display" will be displayed.

If the position driver trips, the front panel display will be forced to display error factor and all digit will flash.

When the exclusive console is connected to the position driver, operation of the front panel becomes inactive.

Mode	Item	Page	Function
Monitor mode	Position deviation monitor	63	Displays the state of the present deviation pulses.
	Velocity monitor	64	Displays the present velocity.
	Torque monitor	64	Displays the present torque output.
	ID No. display	64	Displays the ID No. set in the position driver.
	Present position monitor	65	Displays the present position of the motor.
	Input/output signal monitor	65	Displays the state of the input/output signal. (ON/OFF)
	Error No. display	66	Displays the error No. currently occurring, or past error records
	Parameter display used by the manufacturer	66	
Step data edit mode		67	Sets and changes data for positioning.
Velocity data edit mode		69	Sets and changes positioning velocity, origin return velocity and jogging velocity
NC data edit mode		70	Sets and changes acceleration data, running direction setting, S-shape control setting, input/output signal logic, etc.
Offset data edit mode		71	Sets and changes origin offset and software limit.
Servo parameter edit mode		72	Sets and changes servo parameters such as gain for the position driver.
EEPROM write-in mode		74	Writes-in parameters to EEPROM to make them active even after resetting the power supply.
Automatic gain tuning		75	Executes automatic gain tuning.
Test run		76	Executes jogging, origin returning, step No., etc.

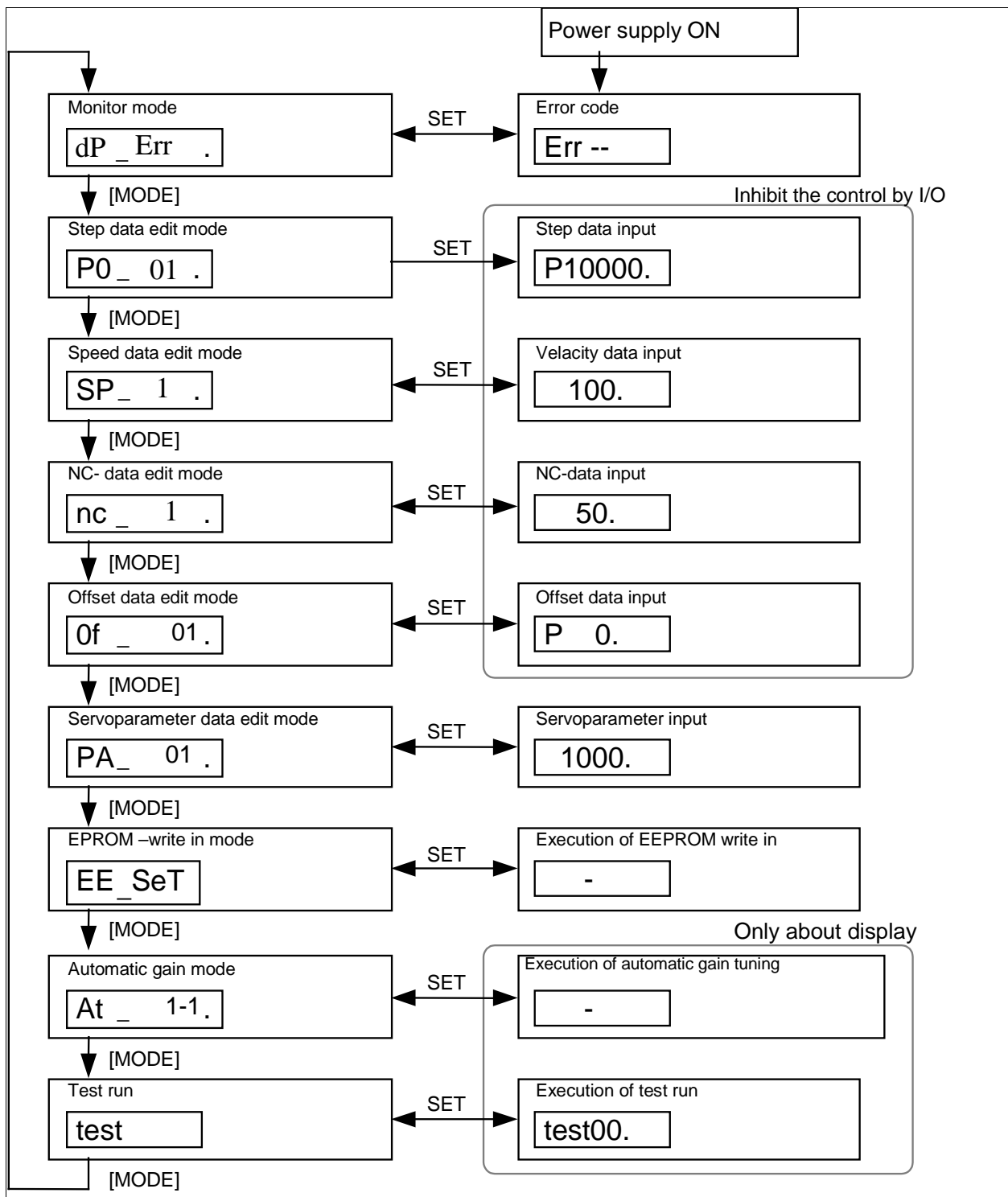

Fig. 10-1 Outline of operation

10.3 Details of operation

10.3.1. Monitor mode

At power-ON, check the LED to make the monitor mode to execution mode(Position deviation, motor speed, torque output, ID No. display, present position monitor, input/output signal monitor, error No. display, or parameter display used by the manufacturer), following the setting of parameter No. 01, „LED initial setting“.

Whenever an error occurs in the position driver, the front panel displays the error No. with flashing, whatever the cause of the error.

Monitor mode consists of monitor function select screen and execution display screen. Changeover the select screen and execution display screen with [SET].

On the selection screen, select the monitor function with ↑ and ↓.

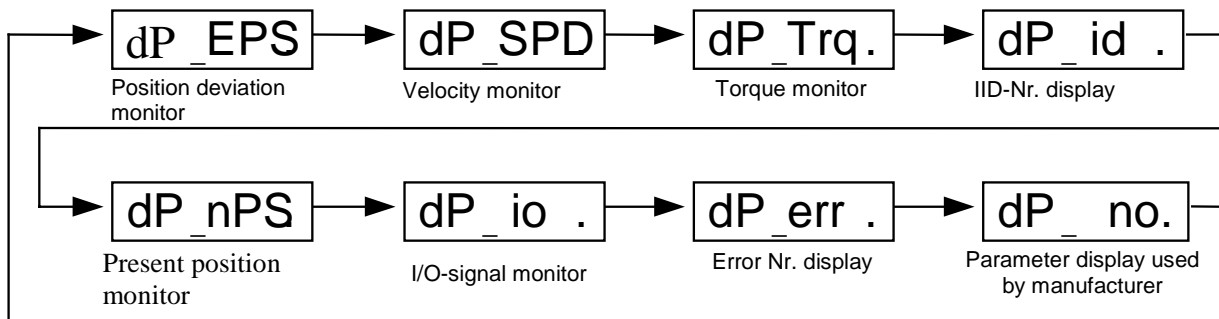

Display varies to the direction the arrow shoes by pressing↑, and reverse direction by pressing ↓.

10.3.1.1. Position deviation monitor

Displays the reserved pulse amount of the deviation counter.

Monitor funktion selection

Display of position deviation



Unit for the display is (pulse).

(+) : Generates the motor torque in CCW direction.

- : Generates the motor torque in CW direction.

Note1) If the polarity is (+), + sign will not be displayed.

Note2) Data of the last 6 digits only will be displayed. If the displayed data is more than 6 digits, "P" will not be displayed.

By pressing [SET], monitor selection screen and position deviation display screen will be changed-over.

By pressing ↑ on the monitor function selection screen it will shift to the monitor function selection screen of the velocity monitor.

By pressing ↓, it will shift to the monitor function selection screen of the parameter used by the manufacturer.

By pressing [MODE] at the monitor function selection screen, it will shift to the step data edit mode.

10.3.1.2. Velocity monitor

Displays the motor rotation speed.

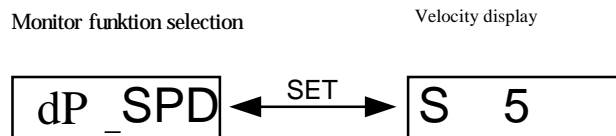

Unit for the display is (kpps).

(+): Generates the motor torque in CCW direction.

-: Generates the motor torque in CW direction.

Note) If the polarity is (+), + sign will not be displayed.

By pressing [SET], monitor selection screen and velocity display screen will be changed-over.

By pressing ↑ on the monitor function selection screen, it will shift to the monitor function selection screen of the torque monitor.

By pressing ↓, it will be shift to the monitor function selection screen of the position deviation monitor.

By pressing [MODE] on the monitor function selection screen, it will be shift to the step data edit mode.

10.3.1.3. Torque monitor

Displays the motor output torque.

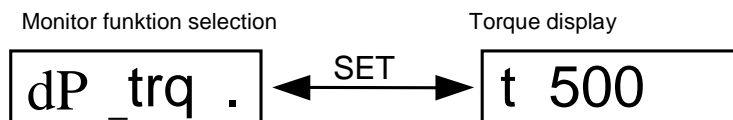

(+) : Generates the motor torque in CCW direction.

- : Generates the motor torque in CW direction.

The relationship of the actual generated torque and the displayed value is described in the following formula:

$$\text{Torque output (\%)} = \text{displayed value}$$

Note) If the polarity is (+), + sign will not be displayed.

By pressing [SET], monitor selection screen and torque display screen will be changed-over.

By pressing [↑] on the monitor function selection screen, it will be shift to the monitor function selection screen of the ID No. monitor.

By pressing [↓], it will be shift to the monitor function selection screen of the velocity monitor.

By pressing [MODE] on the monitor function selection screen, it will be shift to the step data edit mode.

10.3.1.4. ID No. display

Displays the ID No. set in the position driver.

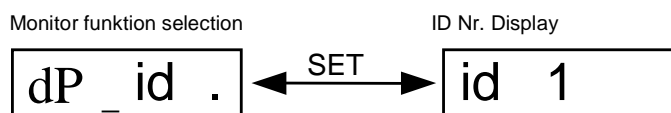

By pressing [SET], monitor selection screen and ID No. screen will be changed-over.

By pressing [↑] on the monitor function selection screen, it will be shift to the monitor function selection screen of the torque display monitor.
By pressing [↓], it will shift to the monitor function selection screen of the present position monitor.

By pressing [MODE] on the monitor function selection screen, it will shift to the step data edit mode.

10.3.1.5. Present position monitor

Displays the present position of the motor.

Monitor funktion selection The present
position display

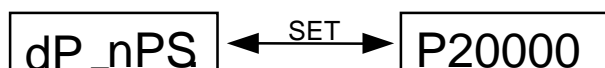

Unit for the display is (pulse).

Note1) If the polarity is (+), + sign will not be displayed.

Note2) While the origin return is not completed, the present position will be displayed as "P...".

Note3) Data of the only last 6 digits will be displayed. If the display data is more than 6 digits, "P" will not be displayed.

By pressing [SET], monitor selection screen and present position display screen will be changed-over.

By pressing [↑] on the monitor function selection screen, it will be shift to the monitor function selection screen of the input/output signal monitor.

By pressing [↓], it will be shift to the monitor function selection screen of the ID No. display.

By pressing [MODE] on the monitor function selection screen, it will shift to the step data edit mode.

10.3.1.6. Input/output signal monitor

Displays the state of the control input/output signal.

Monitor function selection Input / Output
signal display

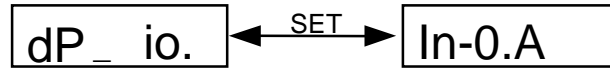

Note1) At the input signal monitor ("In-"), the signal displaying "R" represents the contact closed. With the point assign input ("In-7"), the state of 5-bit input signal is displayed in decimal number.

Note2) At the output signal monitor ("ot-"), the signal displaying "R" represents that the output transistor is turned ON. With the present position output ("ot-3"), the state of 5-bit output signal is displayed in decimal number.

By pressing [SET], monitor selection screen and input/output signal display screen will be changed-over.

By pressing [↑] and [↓] on the input/output signal display screen, select a signal to be referred to.

By pressing [↑] on the monitor function selection screen, it will shift to the monitor function selection screen of the present position monitor.

By pressing [↓] is, it will shift to the monitor function selection screen of the error No. display.

By pressing [MODE] on the monitor function selection screen, it will shift to the step data edit mode.

Signal No. and signal name

Signal No.	Signal name	Symbol	CN I/F pin NO.
IN-0	CW-run limit input	CWL	29
IN-1	CCW-run limit input	CCWL	30
IN-2	Origin vicinity input	ORGL	13
IN-3	Servo-on signal input	SVON	12
IN-4	Strobe signal input	STB	10
IN-5	Emergency stop input	EMG	4
IN-6	n.c.		
IN-7	Point assign input (Note)	P-IN	3534333231
Ot-0	Servo alarm output	ALM	26
Ot-1	Positioning complete output/Decelerating output	COIN/DCLON	25
Ot-2	Motor-running output	BUSY	27
Ot-3	Present position output (Note)	P-OUT	2423171514

Note) For point assign input and present position output, the state of 5-bit input signal is displayed in decimal number.

10.3.1.7. Error No. display

Displays error factors of the past 8 errors including the present one.

code display Monitor function selection Error

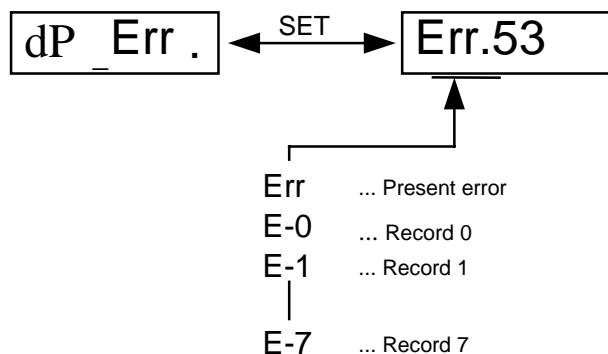

Note1) When no error is occurring, the error code will be shown as "--."

Note2) If an error occurs, which record is kept in the position driver, the present error and record 0 will be displaying the same error code.

By pressing [SET], monitor selection screen and ID No. screen will be changed-over.

By pressing [↑] and [↓] on the error code screen, select the record No. to be referred to

(By pressing [↓], it will shift to older record)

By pressing [↑] on the monitor function selection screen, it will shift to the monitor function selection screen of the input/output signal monitor.

By pressing [↓], it will shift to the monitor function selection screen of the parameter display used by the manufacturer.

By pressing [MODE] on the monitor function selection screen, it will shift to the step data edit mode.

10.3.1.8. Parameter display used by the manufacturer

Displays the parameter values used by the manufacturer.

10.3.2. Step data edit

Sets and changes the necessary step data for executing the positioning.

Note1) For positioning coordinate input, only teaching can be used. To enter the value directly, use a special console (option) or personal computer software (option).

Note2) To execute teaching for the positioning coordinate, the origin return must be done. In case of referring to the step data, the origin return is not required.

Step data selection

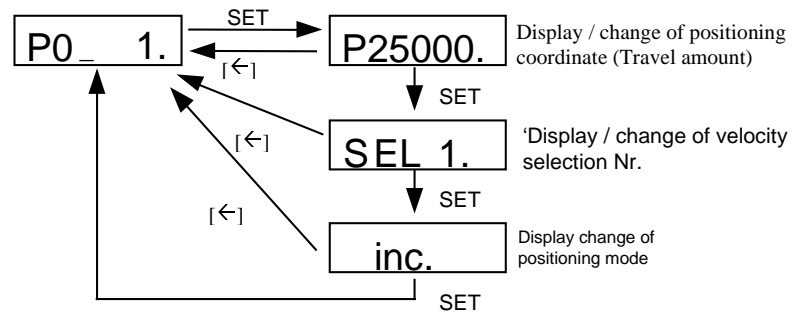

The step data consists of positioning coordinate (travel amount), velocity selection NO. and positioning mode.

Input will be changed-over every time [SET] is pressed. By pressing [←], data during the setting will be canceled and it will shift to the step data No. selection screen.

The step data will be set at the time of pressing [SET] after completing the positioning mode input. If [←] is pressed prior to that, all of the step data inputted by then will be all canceled.

To make the setting data active even after shutting off the power, data must be written into EEPROM.

For data write-in to EEPROM, refer to section 10.3.7 "EEPROM writing".

10.3.2.1. Input of positioning coordinate

- (1) Select a step data No. to be refer to or to be set.

By pressing [↑] and [↓] on the step data selection screen, select a step data No. to be refer to or to be set.

After selecting the step data, press [SET]. It turns to be the positioning coordinate input screen, and the present positioning coordinate will be displayed.

Note) Data of the last 6 digits only will be displayed. If the display data is more than 6 digits, "P" will not be displayed.

- (2) On the positioning coordinate input screen, enter the coordinate data by teaching (possible only when completing the origin return).

By pressing [↑] and [↓], the motor will run at the speed set with the high (speed) jogging.

When the coordinate position is determined, press [SET]. It will shift to the velocity selection No. input screen.

By pressing [←], the input will be canceled, and returns to the step data selection screen.

10.3.2.2. Input of velocity selection No.

Select the velocity No. by pressing [↑] and [↓] on the velocity select No. input screen.

When the velocity selection No. is determined, press [SET]. It will shift to the positioning mode selection screen.

By pressing [←], the input will be canceled and returns to the step data selection screen.

10.3.2.3. Selection of positioning mode

On the positioning mode selection screen, select the positioning mode by pressing [↑]

and [↓] ("A65: Absolute position, "Inc": Relative position).

When the positioning mode is determined, press [SET]. All step data will be set, and it

will shift to the step data selection screen.

By pressing [←], the input will be canceled and returns to the step data selection screen.

10.3.3. Velocity data edit

Sets and changes the reference velocity, the origin return velocity, and the jog velocity to be used for the stepping.

Velocity data Nr. selection
Velocity data display / change

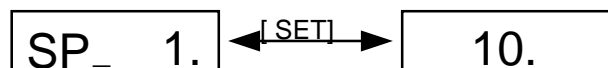

By pressing [SET], velocity data No. selection screen and velocity data display/change screen will be changed-over.

On the speed data No. selection screen, it will shift to NC data edit mode by pressing [MODE].

To make the setting data active even after shutting off the power, the data must be written- in to EEPROM.

For data write-in to EEPROM, refer to section 10.3.7 "EEPROM writing".

Velocity data are listed in the following order.

Velocity No.	Velocity data	Function	Setting range
1	ORIGIN SPEED	Origin return velocity	5 - 500 (kpps) 30-3000 Rpm
2 - 11	STEP SPEED No. 01 - 10	Stepping reference velocity 1 - 10	
12	JOG SPEED (LOW)	Jogging velocity (low speed)	
13	JOG SPEED (HIGH)	Jogging velocity (high speed)	

For details of parameters, refer to section 7.2.2 "Velocity data".

- (1) Select the velocity data No. to be referred to or to be set.
By pressing [↑] and [↓] on the speed data No. selection screen, select a speed data No. to be referred to or to be set.
After selecting the speed data No. to be referred to or to be set, press [SET]. It will shift to the speed data display/change screen and displays the speed data value.
- (2) Change the value of the velocity data.
By pressing [↑] and [], a value of digit indicating decimal point can be changed.
By pressing [↑], the value will be increased and decreased by pressing [↓].
By pressing [←], the position of decimal point can be shifted to the upper digit.
By pressing [SET], the velocity data will be changed and returns to the velocity data No. display screen.

10.3.4. NC data edit

Sets and changes the acceleration, running direction, S-shape control setting, and the input logic.

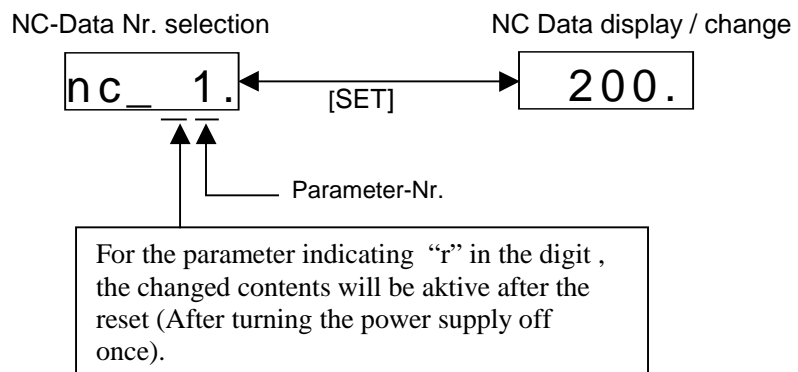

By pressing [SET], NC data No. selection screen and NC data display/change screen will be changed-over.

By pressing [MODE] on NC data No. select screen, it will shift to offset data edit mode.

To make the setting data active even after shutting off the power, the data must be written-

into EEPROM.

For data write-in to EEPROM, refer to section 10.3.7 "EEPROM writing".

NC data are listed in the following order.

Data No.	NC data	Function	Setting range
1	STEP Acc Time	Stepping acceleration/deceleration time	10 - 2000 (ms)
2	JOG Acc Time	Jogging acceleration/deceleration time	10 - 2000 (ms)
3	ORG Acc Time	Origin return acceleration/deceleration time	10 - 2000 (ms)
4	JOG dir	Jogging direction	0 - 1
5	ORG dir	Origin returning direction	0 - 1
6	PLS dir	Pulse output direction setting	0 - 1
7	Teaching Step Pulse	Teaching travel amount setting	0 - 32767
8	S-Curve rate	S-shape acceleration/deceleration setting	0 - 10
9	INPUT Logical	Input logic setting	0 - 8063
10	Option	Option setting	0 - 123

For details of stepping acceleration/deceleration time, jogging acceleration/deceleration time, origin returning acceleration/deceleration time, input logic setting, and option setting, refer to section 7.2.4 "NC data". For details of S-shape control setting, refer to section 9.7 "S-shape acceleration/deceleration function". For setting of jogging direction, origin returning direction, and pulse output direction, refer to section 9.2 "Initial setting of NC parameter".

- (1) Select NC data No. to be referred to or to be set.

By pressing [↑] and [↓] on the NC data No. selection screen, select a NC data No. to be referred to or to be set.

After selecting the NC data No. to be referred to or to be set, press [SET]. It turns to NC data display/change screen and displays the NC data value.

- (2) Change value of the NC data.

By pressing [↑] and [↓], value of digit indicating decimal point can be changed.

By pressing [↑], the value will be increased, and decreased by pressing [↓].

By pressing [←], the position of decimal point can be shifted to the upper digit.

By pressing [SET], the NC data will be changed and returns to NC data No. display screen.

10.3.5. Offset data edit

Sets and changes the origin offset and the software limit.

Note1) For offset coordinate input, only a teaching can be used. To enter the value directly, use a special console (option) or personal computer software (option).

Note2) To execute a teaching for the offset coordinate, origin return must be done. In case of referring to the offset data, origin return is not required.

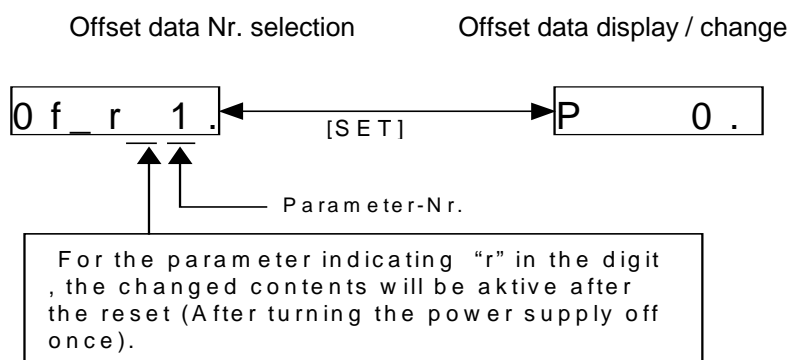

By pressing [SET], offset data will be set. If [←] is pressed, offset data entered by then will be canceled.

To make the setting data active even after shutting off the power supply, the data must be written-in to EEPROM.

For data write-in in EEPROM, refer to section 10.3.7 "EEPROM writing".

Offset data are listed in the following order.

Data No.	Offset data	Function	Setting range
1	Origin offset	Origin offset	-1073741824 - 1073741823 (pulse)
2	Soft Limit (PLUS)	+ direction software limit	0 - 1073741823 (pulse)
3	Soft Limit (MINUS)	-direction software limit	-1073741824 - 0 (pulse)

For details and setting range of each parameter, refer to section 7.2.3 "Offset data".

10.3.5.1. Input of offset coordinate

- (1) Select offset data No. to be referred to or to be set.
By pressing [↑] and [↓] on the offset data selection screen, select a offset data No. to be referred to or to be set.
After selecting the offset data, press [SET]. It turns to offset coordinate input screen, and the present offset coordinate will be displayed.

Note) Data of the last 6 digit only will be displayed. If the display data is more than 6 digits, "P" will not be displayed.

- (2) On the offset coordinate input screen, enter coordinate data by teaching (possible only when completing the origin return).
By pressing [↑] and [↓], the motor runs at the speed set with the high (speed) jog velocity.
If the coordinate is determined, press [SET]. Offset data will be set and shifts to the offset data selection screen.
If [←] is pressed, the input will be canceled, returning to the offset data selection screen.

10.3.6. Servo parameter edit

Sets and changes servo parameters of the position driver.

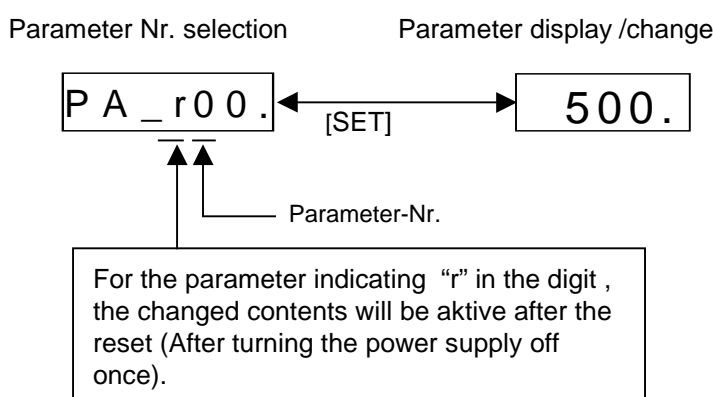

By pressing [SET], parameter No. selection screen and parameter display/change screen can be changed-over.

If [MODE] is pressed on the parameter No. selection screen, it will shift to EEPROM write-in mode.

To make the setting data active even after shutting off the power supply, the data must be written-in to EEPROM.
For data write-in to EEPROM, refer to section 10.3.7 "EEPROM write-in".

Servo parameters are listed in the following order.

Data No.	Servo parameters name	Setting range
00	Name of axis	0 - 31
01	LED initial display	0 - 7
03	Velocity loop gain	25 - 3500
04	Velocity loop integration time constant	1 - 1000
05	Velocity detection filter	0 - 4
06	Torque limit setting	0 - 300
08	Velocity monitor gain selection	0 - 1
09	Inactive run-limit input	0 - 1
10	Startup delay time	0 - 600
20	Position loop gain	0 - 1000
21	Velocity feed forward	0 - 100
22	Positioning complete range	0 - 32766
23	Position error limit setting	1 - 32766
24	Cancel of position error limit	0 - 1
2A	Torque filter time constant	0 - 2500
2B	Feed forward filter time constant	0 - 6400
30	2 nd . velocity loop gain	25 - 3500
31	2 nd . velocity loop integration time constant	1 - 1000
32	2 nd . position loop gain	10 - 1000
33	2 nd . gain operation setting	0 - 1
34	2 nd . gain changeover delay time	0 - 10000
39	Excessive position deviation setting at Servo-Off	
3B	Velocity monitor signal selection	0 - 1
3D	Sequence at alarm	0 - 3
3E	Sequence at the servo-off	0 - 7

For details and setting contents of each parameter, refer to section 7.3 "Details of servo parameters (User parameters)".

- (1) Select parameter No. to be referred to or to be set.
By pressing [↑] and [↓] on the parameter selection screen, select a parameter No. to be referred or to be set.
If the parameter No. is selected, press [SET]. It will shift to the parameter display/change screen, and the parameter value will be displayed.
- (2) Change the value of parameter.
By pressing [↑] and [↓], a value of digit indicating decimal point can be changed.
By pressing [↑], the value will be increased, and decreased by pressing [↓].
If [←] is pressed, the position of the decimal point can be shifted to upper digit.
By pressing [SET], the parameter will be immediately changed, and the contents will be reflected against the motor control.

Note 1) For the number of digit for shifting decimal point position to the upper digit, it is limited for each parameter.

Note 2) For change of value for parameters which affect greatly to the motor action (especially, velocity loop gain, position loop gain, etc.), do not change the value excessively at once, and execute the change little by little. Also, input of [←] (shift key) is inhibited depending on the parameter.

10.3.7. EEPROM write-in

Writes-in the preset parameter (NC parameter, servo parameter) to EEPROM.

Without write-in to EEPROM, it will return to the parameter at the previous power-ON, when resetting the power supply.

EEPROM write in mode

Execution of EEPROM write- in



By pressing [SET], EEPROM write-in mode screen and write-in execution screen can be changed-over.

On EEPROM write-in screen, it will return to automatic gain tuning mode if [MODE] is pressed.

- (1) Press [SET] and to turn to EEPROM write-in execution screen.
- (2) On write-in execution screen, write-in will start when "StArt" is displayed by pressing [↑] continuously.

Execution of EEPROM write-in

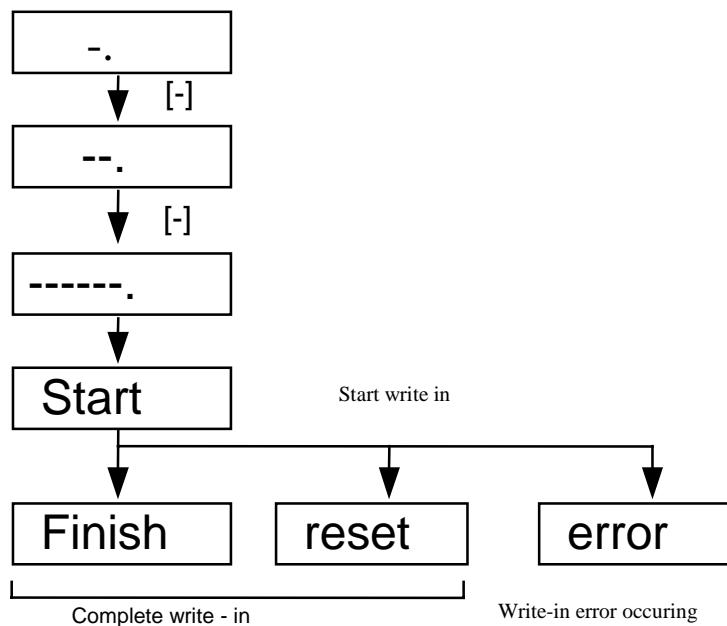

- (3) If the write-in is completed, either of "F In 15h", "rE5EE" or "Error" will be displayed.
- (4) When the setting/changing of the parameter which becomes active after resetting, "rE5EE" will be displayed at the completion of write-in.
Shut off the power supply once, and reset.
- (4) If [↑] is pressed continuously at the completion of write-in EEPROM, re-write-in of the parameter can be executed.

Note1) If "Error" is displayed, it represents that a write-in error occurs at writing-in to EEPROM.
If such writing error occurs, execute the write-in again. If write-in error occurs repeatedly, the position driver may be a failure.
Contact with a distributor.

Note2) Do not shutoff the power during writing-in to EEPROM.
Incorrect data may be written-in. In case of such situation, reset all parameters, and perform write-in again after a complete check.

10.3.8. Automatic gain tuning

Executes the automatic gain tuning function.

Note1) For details of the automatic gain tuning function, refer to section 4.4 "Automatic gain tuning".
Especially, execute this automatic gain tuning function after fully understanding applicability, cautions, etc. described in section 4.4.

Note2) At the automatic gain tuning mode, the motor runs 2 rotations to the CCW direction, and 2 rotations to the CW direction.
Therefore, move the load to the position where no trouble is expected even with 2 rotations of the motor.

Automatic gain tuning mode Execution of automatic gain tuning

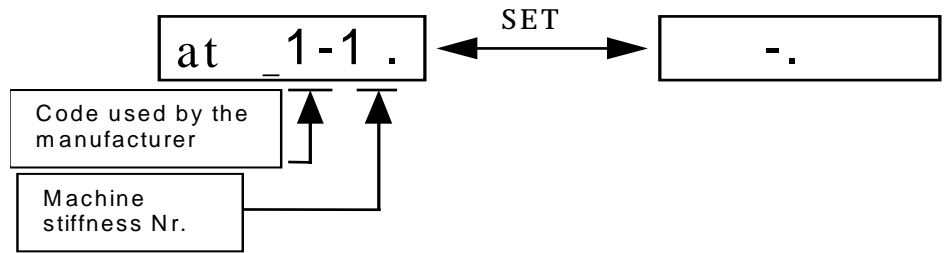

By pressing [SET], automatic gain tuning mode screen and execution screen can be changed-over.

On the automatic gain tuning mode screen, it will shift to the test-run mode if [MODE] is pressed.

To make the preset data by the automatic gain tuning function active, even after shutting off the power, data must be written-in to EEPROM after completing the automatic gain tuning.

For data write-in to EEPROM, refer to section 10.3.7 "EEPROM write-in".

(1) Set the machine stiffness.

By pressing [↑] and [↓] on the automatic gain tuning mode screen, select the machine stiffness No.

For the machine stiffness No., refer to section 4.4.

(2) Enter a Servo-ON signal.

(3) Tuning will be start when "StArt" is displayed by continuously pressing [↑] on the tuning execution screen.

Automatic gain tuning execution

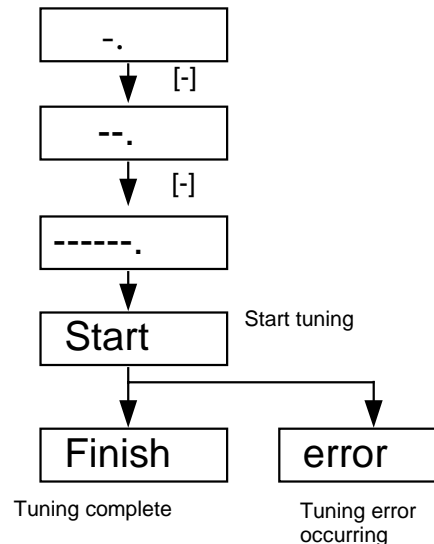

- (4) When the automatic gain tuning is completed, either of "F In 15h" or "Error" will be displayed.
- (5) If [↑] is pressed continuously at completion of the automatic gain tuning, the tuning can be executed again.

Note3) Even if the automatic tuning mode is executed and completed normally, no improvement of the machine action may be made, if the gain deviated from „applicable range“ described in section 4.4.2 (gain before/after the automatic gain tuning will not be changed.). In such a case, execute the gain adjustment manually in accordance with section 6.2 "Gain adjustment".

10.3.9. Test-run

Test-run can be executed for jogging, origin returning, and stepping, with the front panel.



By pressing [SET], test-run screen and point No. selection screen can be changed-over.

On the test-run screen, it will shift to the monitor mode if [MODE] is pressed.

- (1) Changeover to point No. selection screen.
- (2) Set the point No. of to be operated.

By pressing [↑] and [↓], changeover the point No.

The relationship of point No. and run command is as follows:

Point No.	Contents
0	Reset command
1	Travels to step data 1.
2	Travels to step data 2.
3	Travels to step data 3.
4	Travels to step data 4.
5	Travels to step data 5.
27	Travels to step data 27.
28	Travels to step data 28.
29	High speed jogging (- direction)
30	High speed jogging (+ direction)
31	Origin return command

Note) Stepping cannot be executed without completing the origin return.

- (3) By pressing [←], action of the assigned point No. will be executed.
In case of the jogging, the motor will be running while pressing [←].
While executing the command, "EE5E--" will be displayed.
- (4) If the action is completed, it will turn to the point No. selection screen and the point No. will be displayed.
By pressing [←], run command can be executed again.

11 Specification

11.1 General specification

Machine model		Sym- bol	DMD02.1- W012	DMD02.1- W022	DMD02.1- W042	DMD02.1-082
B A S I C F U N C T I O N	Applied motor series MMD		MMD012A	MMD 022A	MMD042A	MMD082A
	Applied motor output	W	100	200	400	750
	Cont. Input current (3-phase)	A	0.7	1.1	1.8	4.0
	Continuous Output Current I_{cont}	A	1.0	1.7	2.5	4.3
	Momentary Max. Output Current I_{peak}	Ao-p	4.3	6.9	10.5	18.3
	Input power supply	200V-series	200 - 230V +10% / -15% 50 / 60Hz			
	Control system		Transistor PWM system (Sine wave drive)			
	Encoder specification		Incremental encoder (2500P/r 10 wires)			
	Ambient Conditions	Temperature	Working temperature 0 - (0 - for the special console) Storage temperature -20 -			
		Humidity	Working/storage humidity 90%RH or under (No dewing)			
Vibration		4.9m/s ² (0.5G) or under, 10 - 60Hz (Continuous use at the resonance point is not available.)				
F U N C T I O N S I G N A L O U T P U T	Control mode		Position/Velocity control, Sequencer I/O command system			
	Control signal		(1) Emergency stop (2) Strobe (3) Servo-on input (4) Point assign (5-bit) (5) CW-run limit input (6) CCW-run limit input (7) Origin vicinity input			
	Control output		(1) Motor -running output (2) Positioning complete output/decelerating output (3) Servo alarm (4) Present point output (5-bit)			
	Monitor output		(1) Velocity monitor Approx. 6V /500kpps or Approx. 1.5V/500kpps (Selected by parameter) Deviation counter monitor Approx. 8.2V/255pulse or Approx.8.2V/32767pulse (Selected by parameter) Select velocity monitor or deviation counter monitor. (2) Torque monitor Approx. 3V/Rated torque			

B U I L T I N F U N C T I O N	Regeneration		Built-in regenerative resistance (see "11.3 Regenerative energy)	
	Dynamic brake function		Built-in (1) At servo-off (2) At alarm occurrence (3) At power supply-off (4) At deceleration in case that CW or CCW-run limit input is active. (Possible to be inactive by parameter)	
	Automatic gain tuning function		Built-in (Depending on the machine type of the applicable motor)	
	Masking function for unnecessary input wires.		Available Input which can be masked (1)Run limit input (CW/CCW)	
	Protection function	Hardware error	Overvoltage, undervoltage, overspeed, overload, overcurrent, encoder error, etc.	
		Software error	CPU error, system error, etc.	
	Trace back function of alarm data		Storage of up to past 8 alarms including the present one.	
	Setting switch / LED display		(1) Switch 5pcs. (MODE, SET, UP, DOWN, SHIFT) (2) Rotary switch for ID setting (3) Switch for terminator (4) LED 6 digit	
	Communication function by RS-232C		Parameter setting, monitoring of the control state, etc. are available by using a console and a personal computer.	
	Per- for- man- ce	Applied load inertia		Smaller than 30 times of the motor inertia (400W or lower)
Product weight		About 0.9 kg	About 1 kg	
				About 1.2 kg

11.2 Functional specification

Item	Contents
Programmable point number	28 points
Position command input signal Present position output signal	5-bit
Max. position command (pulse)	31-bit with symbol (-1073741824 - 1073741823)
Position command status	ABS/INC (Absolute position/relative position) can be specified for each step.
Velocity range	Max. 500kpps (3000r/min.)
Velocity setting	5kpps - 500 kpps (6r/min./kpps) Setting in 1 kpps unit. The following contents can be set respectively. Jog velocity (high speed/low speed) Origin return velocity Step velocity (typical 10)
Acceleration/deceleration setting	Setting by linear acceleration/deceleration time up to 500kpps. 10ms. - 2s. Acceleration/deceleration resolution 10ms. Unit S-shape control is available (At the stepping and the jogging acceleration)
Origin return function	Origin sensor + Z-phase
Memory status	EEPROM backup

11.3 Regenerative energy

Condition: Permissible regenerative energy (Continuous regen) is determined, considering the temperature-rise of the driver at the rating output.

Indramat	Capacitor (F)	Stored energy of Capacitor (J)	Peak regen power (W)	Continuous regen power (W)
DMD02.1-W012N with MMD012A	270	8.91	1600	10
DMD02.1-W022N with MMD022A	270	8.91	1600	5
DMD02.1-W042N with MMD042A	540	17.82	1600	7
DMD02.1-W082N with MMD082A	810	26.73	1600	5

11.4 Dimensions

11.3.1. DMD02.1-W012 and DMD02.1-W022

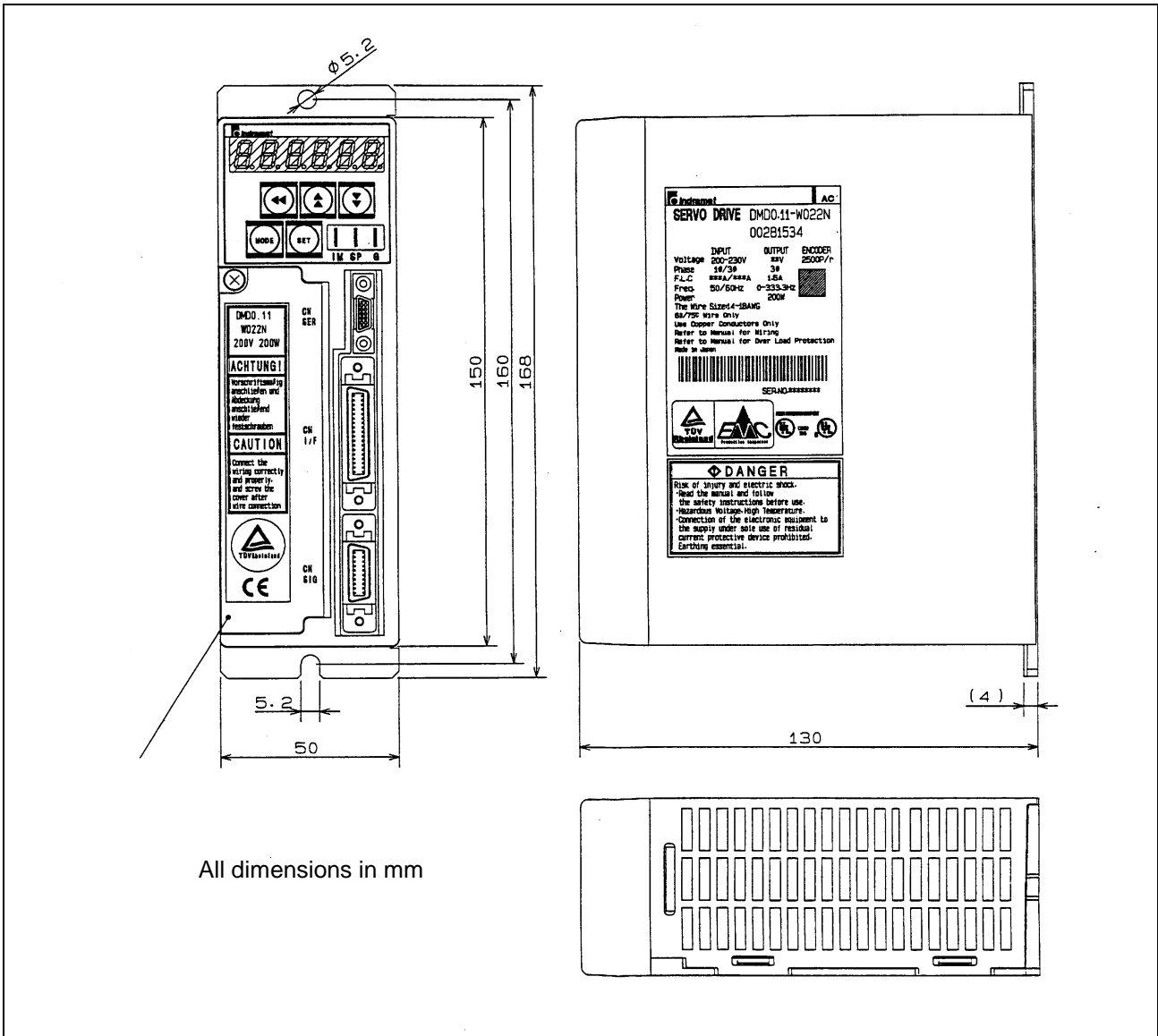

Fig. 11-1: DMD02.1-W012 & DMD02.1-W022

11.3.2. DMD02.1-W042

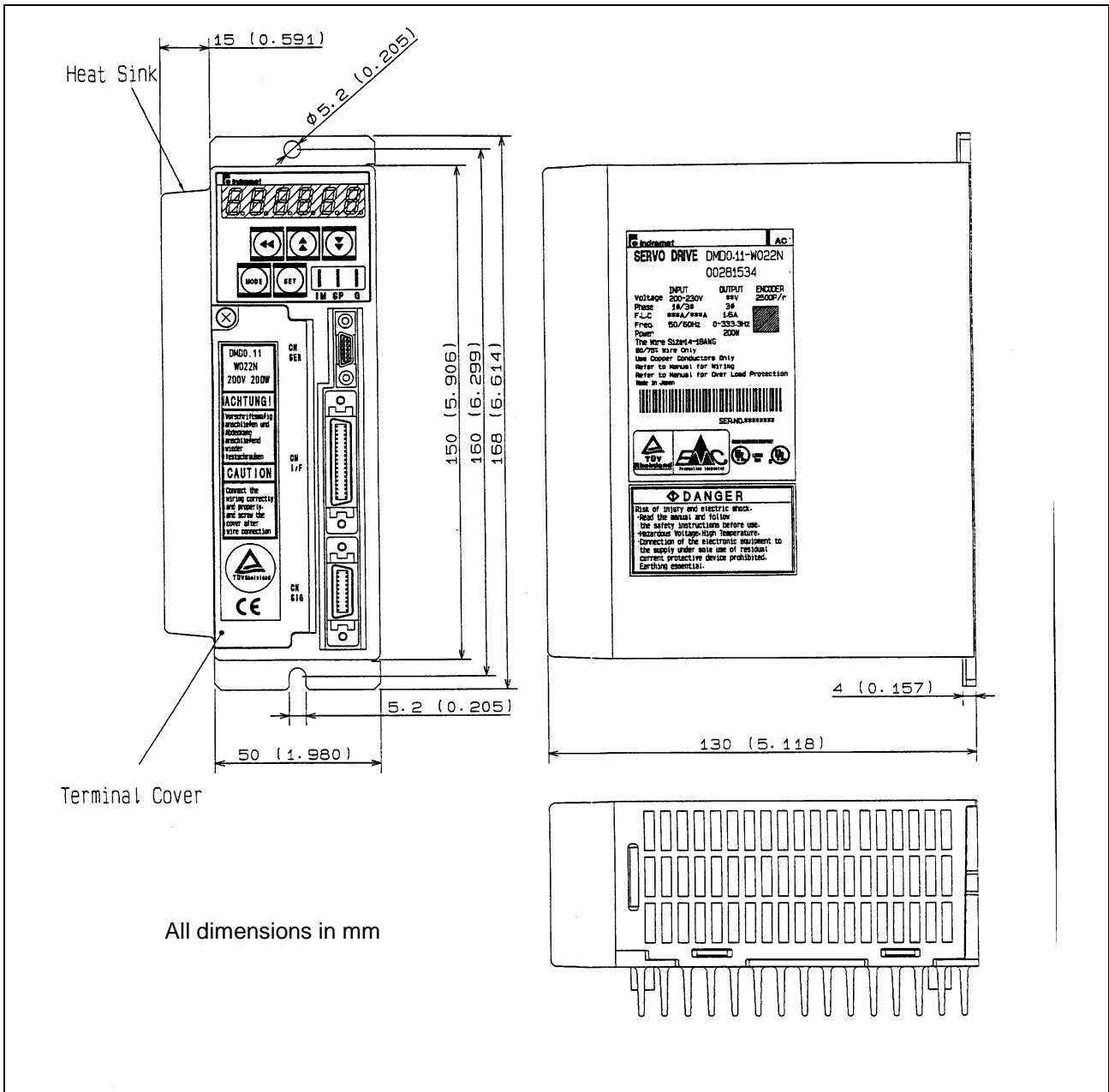

Fig. 11-2: DMD02.1-W042

11.3.3. DMD02.1-W082

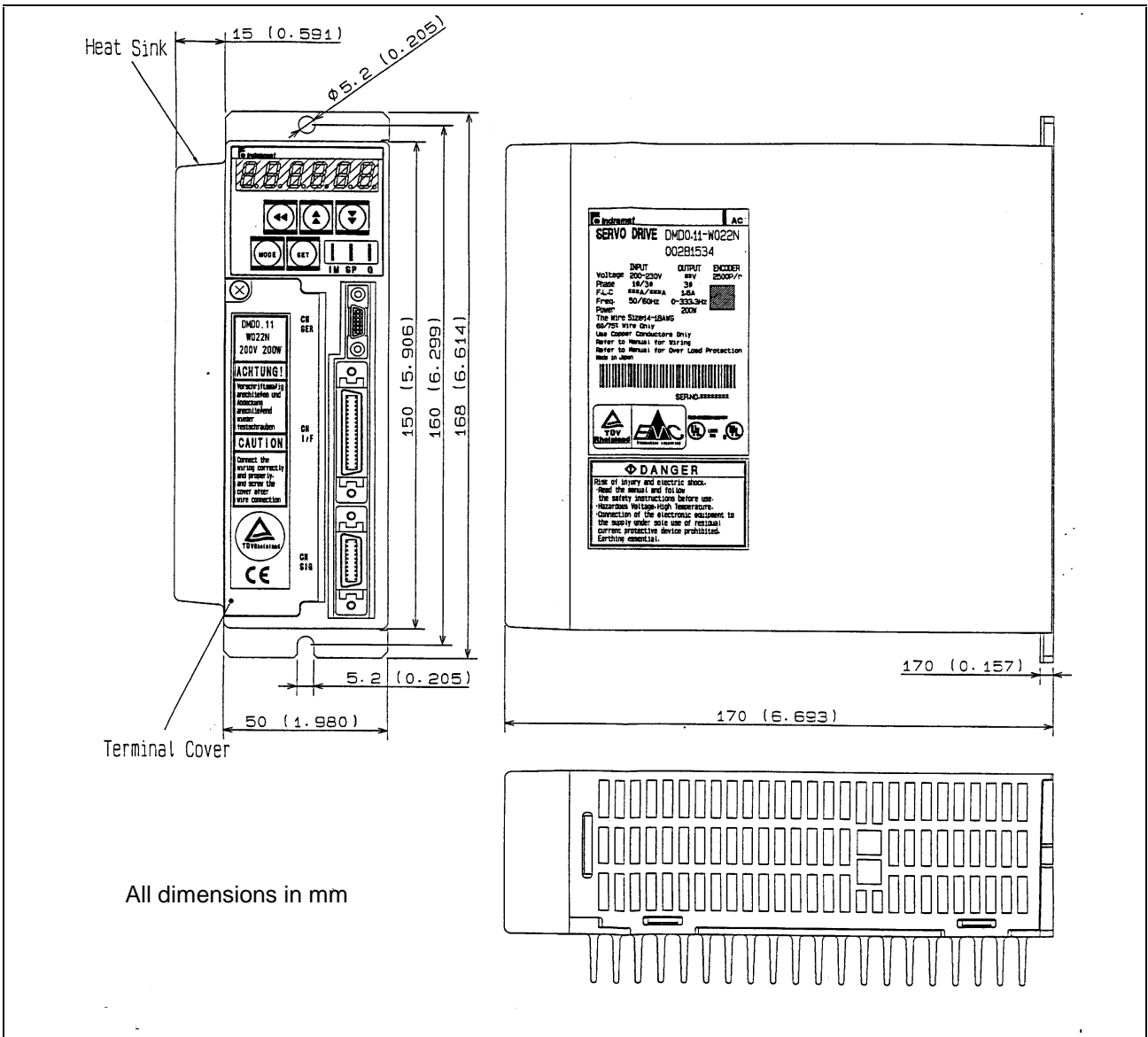

Fig. 11-3: DMD02.1-W082

12 Typecode

12.1 Type Code – Drive controller

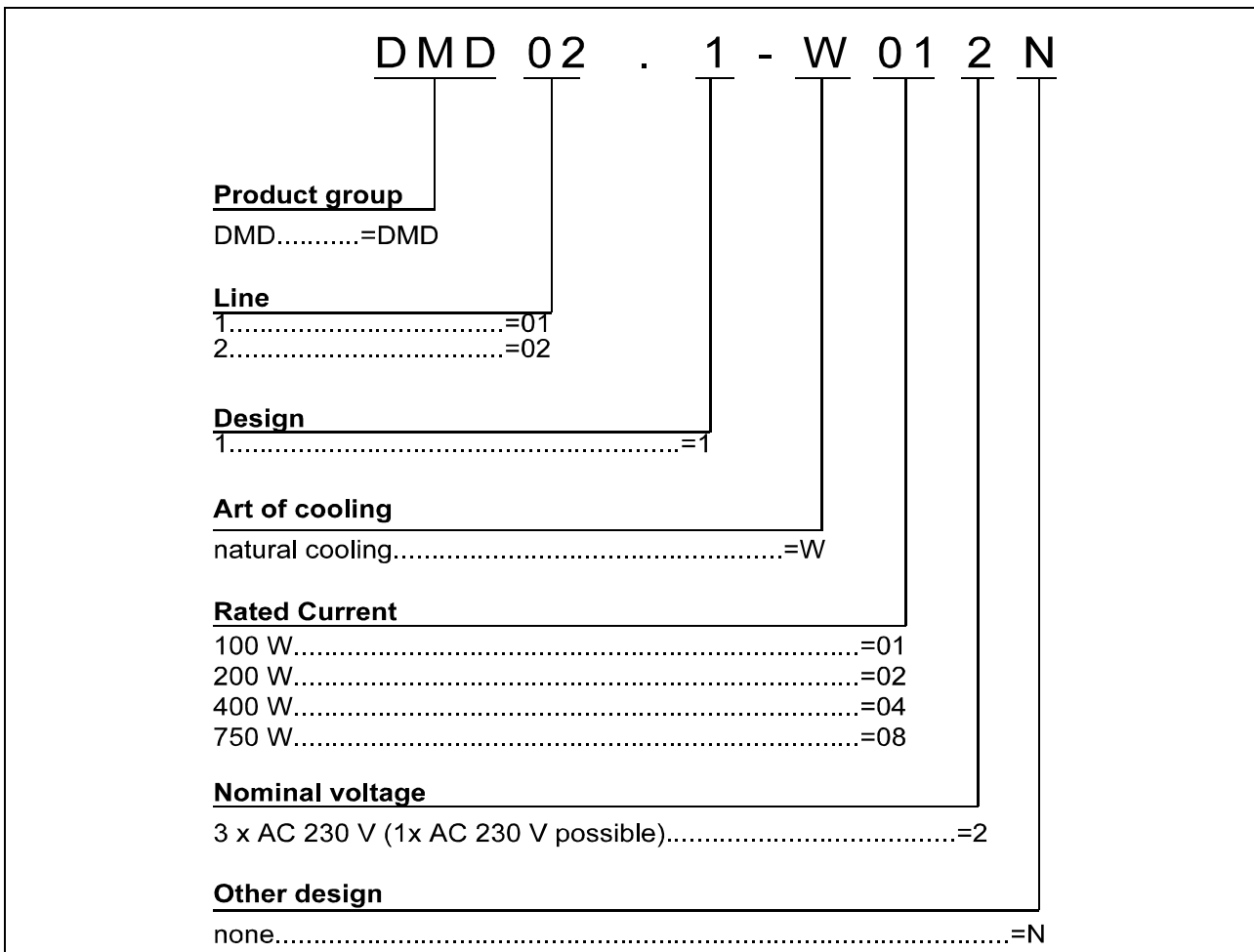

Fig. 12-1 Type code – drive controller

12.2 Type code – Motor

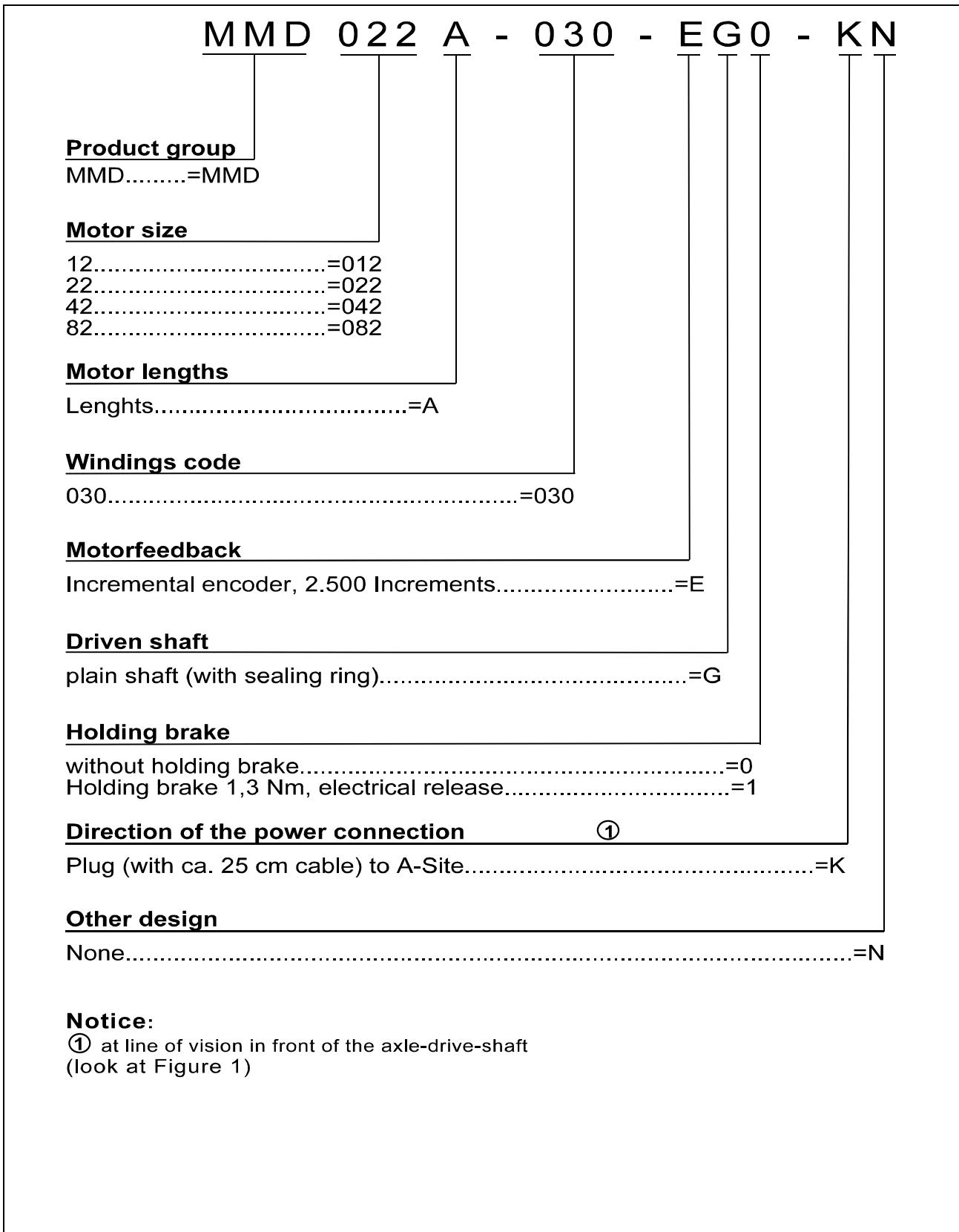

Fig. 12-2 Type code - motor

13 MMD - Motor

13.1 Mechanical integration into the machine

13.1.1. Conditions of use

Nominal data

Maximum installation elevation and ambient temperatures

The performance data specified for the motor apply to:

- an ambient temperature range of 0° to +40° C
- and an installation elevation of 0 to 1000 m above sea level.

Exceeding nominal data

If the motors are used above this range then the "load factors" must be taken into consideration. This derates the performance data.

⇒ In such cases, check whether the performance data still suffice for your specific application. To determine load factors, use Fig. 13.1. Values that are higher than depicted for temperature or installation are not permissible!



WARNING

Motor damage and forfeiture of guarantee!

Motors used outside of their specific applications can be damaged. The guarantee is then forfeited.

⇒ Therefore, please note the following instructions!

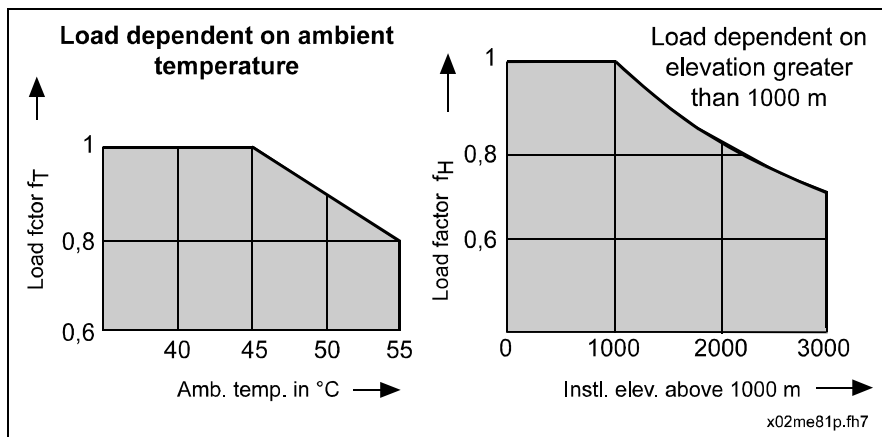

Fig. 13-1: Load factor in terms of ambient temperature and installation elevation

If **either** ambient temperature **or** installation elevation exceed nominal ratings then:

- ⇒ Multiply the continuous standstill torque listed in the selection data with the determined load factor.
- ⇒ Make sure that the derated torque is not exceeded by your application.

If **both** ambient temperature **and** installation elevation exceed nominal data:

- ⇒ multiply the determined load factors f_T and f_H
- ⇒ multiply the determined value by the continuous standstill torque of the motor indicated in the selection data
- ⇒ make sure that the derated torque data is not exceeded by your application.

Protection category

The design of the MMD motors meets the protection category requirements as described in DIN VDE 0470, section 1, edition dated 11/1992:

The areas of the motor	Protection category
motor housing, output shaft, power and feedback cables and brake cable (without connector and only with proper mounting)	IP 65

Fig. 13.2: Parts of the MMD motors for which protection categories apply

The protection category is coded with the abbreviation IP (international protection) and two distinctive numbers for the degree of protection.

The **first distinctive number** describes the level of protection against contact and penetration by extrinsic objects.

Number 6 means

- protection against penetration by dust (dust-proof)
- and complete contact protection

Number 4 means

- protection against penetration by extrinsic objects with a diameter exceeding 1 mm.

Number 2 means

- protection against penetration by extrinsic objects with a diameter exceeding 12 mm

- as well as keeping fingers or similar objects out.
The **second distinctive number** describes the protection category against water.
Number 5 means
- protection against a jet of water out of a nozzle sprayed at the housing from all directions (jet of water).
Number 4 means
- protection against water being sprayed at the housing from all directions (spray of water).



WARNING

Danger to personnel or damage to property!

Improperly mounted power and feedback connections can injure personnel or damage the motor!

- ⇒ Make sure that the power and feedback connections are mounted by properly trained personnel.
 - ⇒ Use MMD motors only in an environment where the indicated protection categories can be ensured.
-

13.2 Technical data

Designation	Symbol	Unit	Data			
			MMD012A	MMD022A	MMD042A	MMD082A
Motor type			MMD012A	MMD022A	MMD042A	MMD082A
To work with drive controller family			DMD	DMD	DMD	DMD
Drive controller			DMD02.1-W0 12	DMD02.1-W0 22	DMD02.1-W0 42	DMD02.1-W0 82
Nominal motor speed ¹⁾	n	min ⁻¹	3000	3000	3000	3000
Maximum theoretical speed	n _{max}	min ⁻¹	5000	5000	5000	4500
Continuous torque at standstill ²⁾	M _{dN}	Nm	0.32	0.64	1.3	2.4
Maximum theoretical torque	M _{dN}	Nm	0.95	1.91	3.36	6.9
Rotor moment of inertia without brake	J _M	kgm ²	0.063 x 10 ⁻⁴	0.17 x 10 ⁻⁴	0.37 x 10 ⁻⁴	1.33 x 10 ⁻⁴
Rotor moment of inertia with brake	J _M	kgm ²	0.067 x 10 ⁻⁴	0.2 x 10 ⁻⁴	0.4 x 10 ⁻⁴	1.41 x 10 ⁻⁴
Brake power supply	24V / 0,4 A					
Impulses of incremental Encoder	I	I/min ⁻¹	2500			
Weight without brake	m _M	kg	0.53	0.96	1.6	3.1
Weight with brake	m _M	kg	0.73	1.4	2.0	3.7
Electrical connection			Plugin Connector	Plugin Connector	Plugin Connector	Plugin Connector
Working and storage humidity		%	85			
Permissible ambient temperature ²⁾	T _{um}	°C	0 to +40			
Permissible storage and transport temperature	T _L	°C	-20 to +80			
Maximum installation elevation ³⁾		m	1000 above NN			
Protection category ⁴⁾			IP 65			
Housing finish			Primary beige coat			
<p>1) Depends on torque requirements of application. For applications determine the usable speed in terms of the required torque via the speed/torque characteristics.</p> <p>2) With deviating ambient temperatures see figure 13.1</p> <p>3) With deviating installation elevations see figure 13.1</p> <p>4) With correct mounting of power brake and feedback cables.</p>						

Fig. 13.3: Load factor in terms of ambient temperature and installation elevation

13.3 Characteristics

13.3.1. MMD012A – 100W

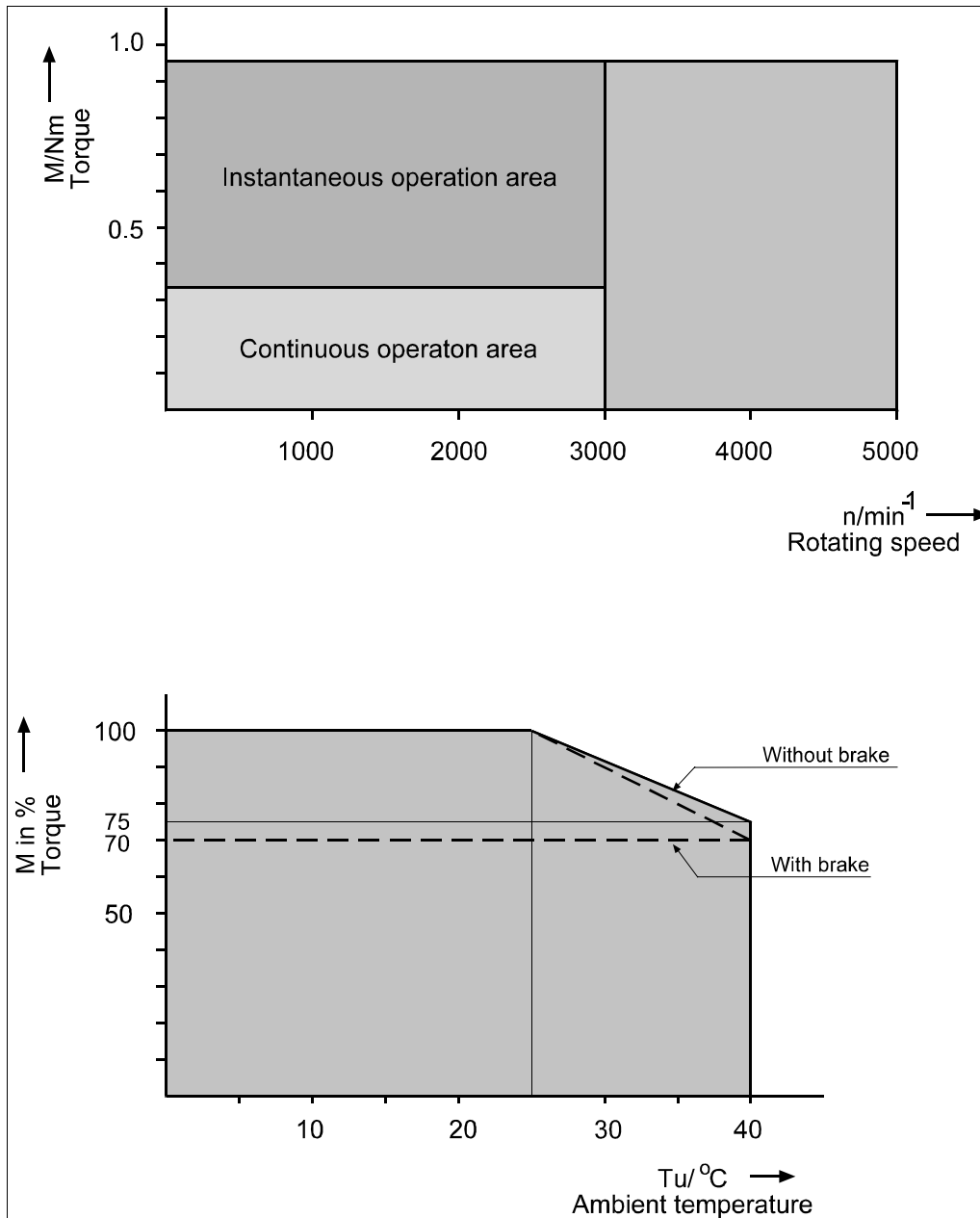

Fig. 13.4: Load factor in terms of ambient temperature and installation elevation

13.3.2. MMD022A – 200W

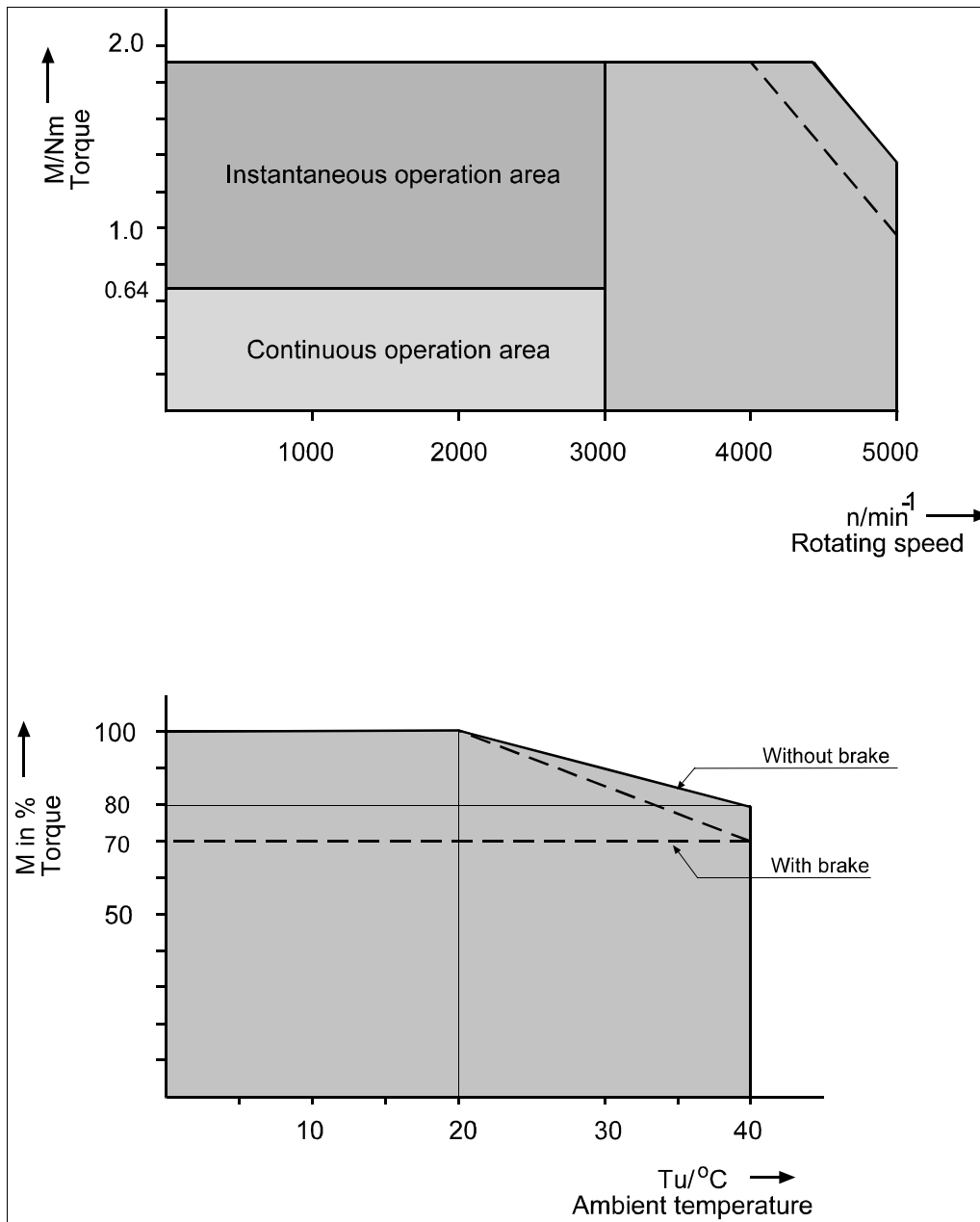

Fig. 13.5: Load factor in terms of ambient temperature and installation elevation

13.3.3. MMD042A – 400W

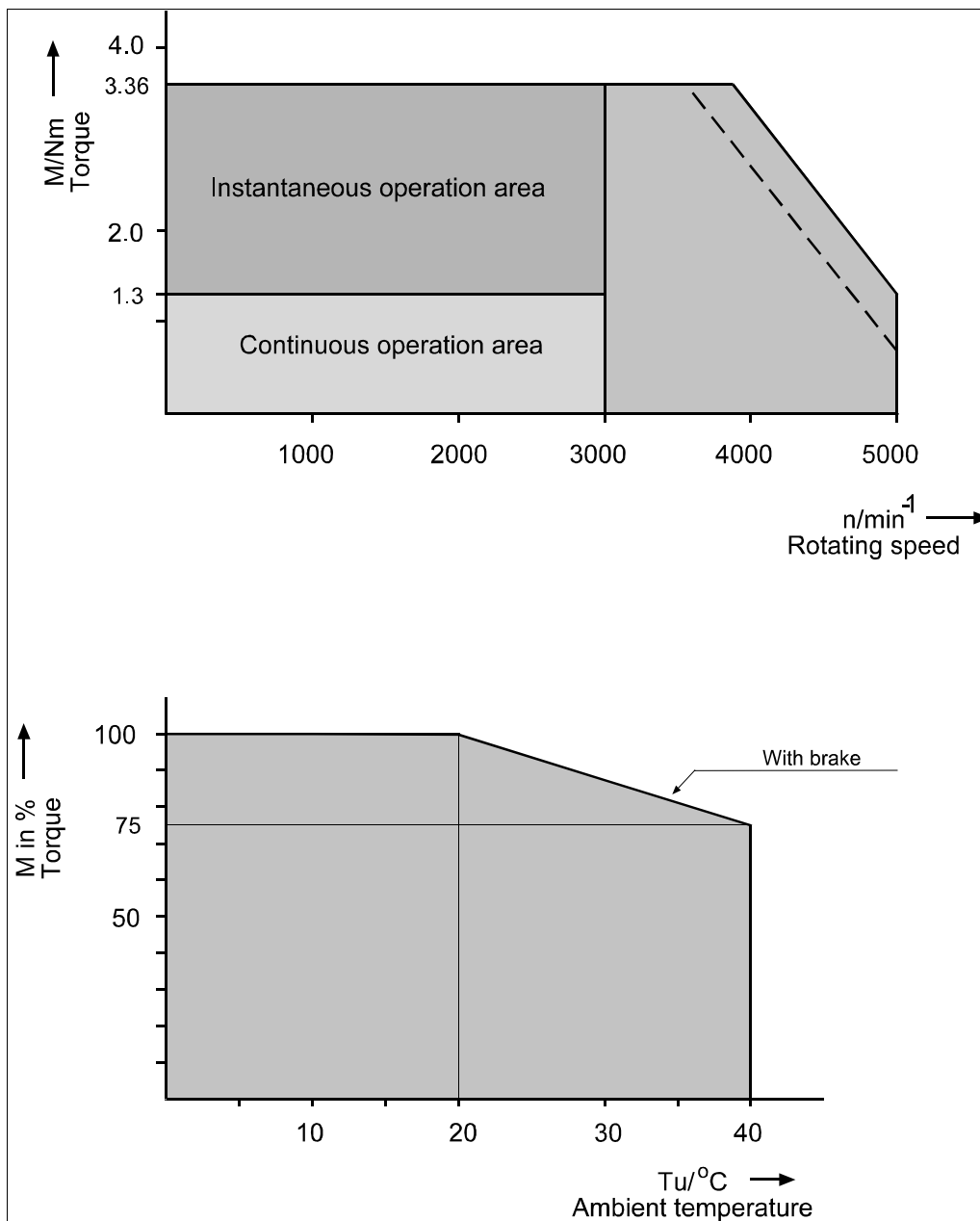

Fig. 13.6: Load factor in terms of ambient temperature and installation elevation

13.3.4. MMD082A – 750W

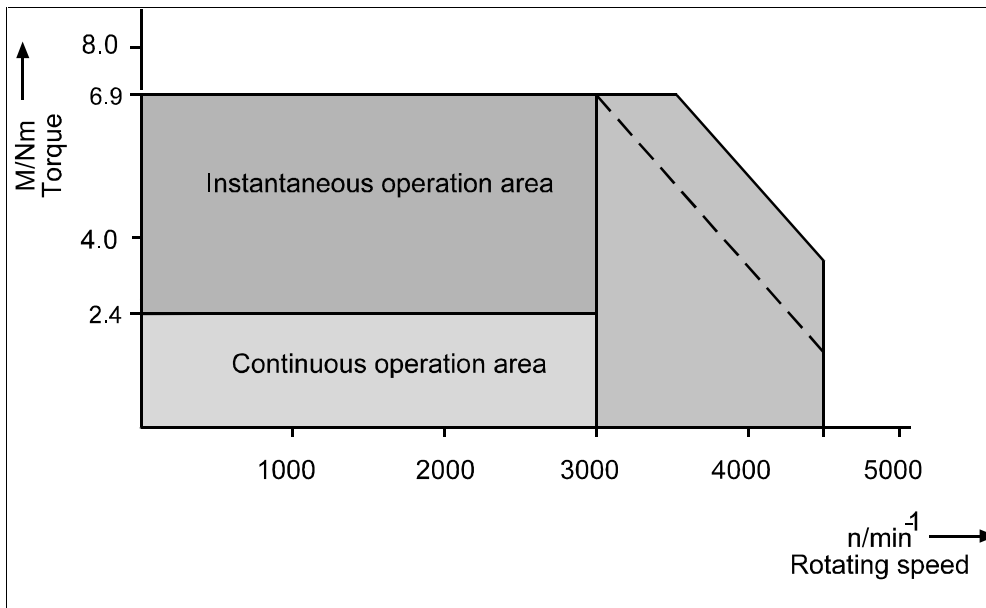
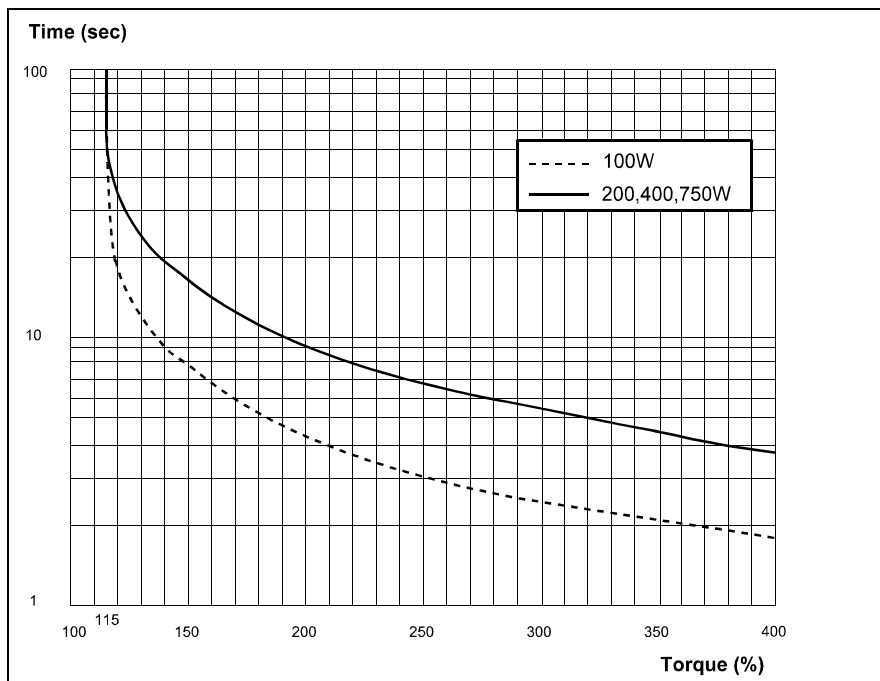

Fig. 13.7: Load factor in terms of ambient temperature and installation elevation

13.3.5. Instantaneous operation area

MMD Series Over Load Protection Time-Torque-Curve



13.4 Dimensional data

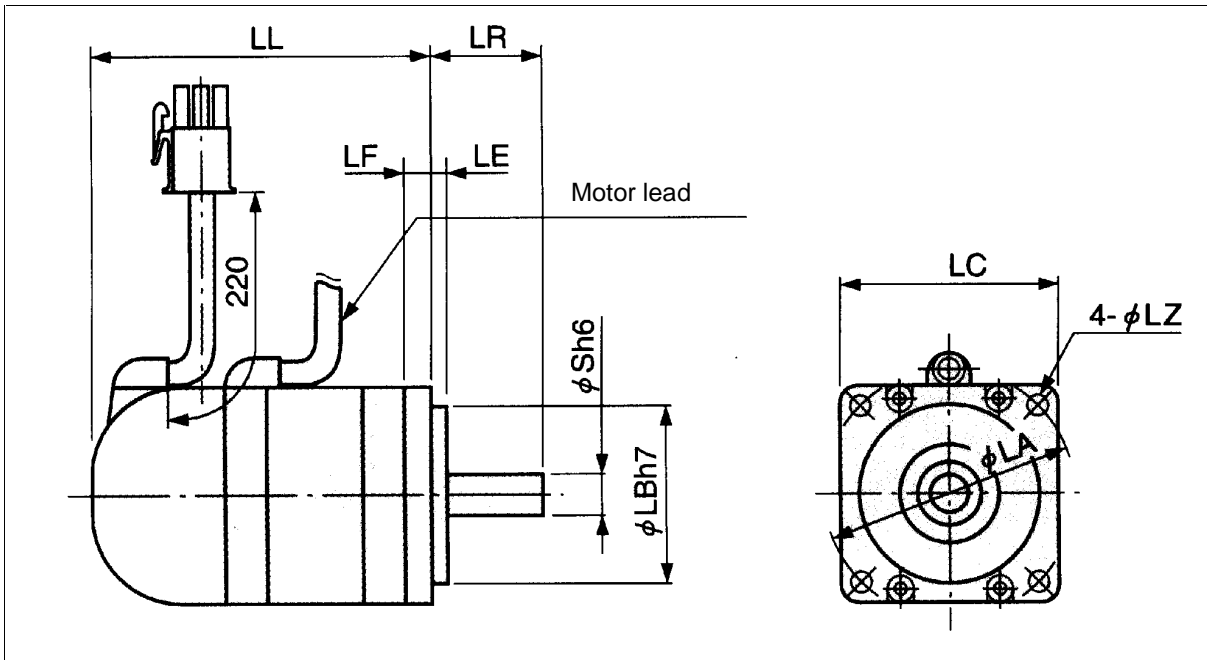

All dimensional data in mm				
	MMD012A	MMD022A	MMD042A	MMD082A
LL (Incremental encoder with brake)	135	128	157	178
LL (Incremental encoder without brake)	103	95	124	143
LR	25	30	30	35
φS ^{h6}	8	11	14	19
LA	45	70	70	90
φLB ^{h7}	30	50	50	70
LC	38	60	60	80
LE	3	3	3	3
LF	6	7	7	8
LZ	3.4	4.5	4.5	6

Fig. 13.8: Dimensional data MMD-Motor

Kundenbetreuungsstellen - Sales & Service Facilities

Deutschland – Germany

vom Ausland:
from abroad:

(0) nach Landeskenziffer weglassen!!
don't dial (0) after country code!

Vertriebsgebiet Mitte Germany Centre <input checked="" type="checkbox"/> V/S <input checked="" type="checkbox"/> Service	Vertriebsgebiet Ost Germany East <input checked="" type="checkbox"/> V/S <input checked="" type="checkbox"/> Service	Vertriebsgebiet West Germany West <input checked="" type="checkbox"/> V/S <input checked="" type="checkbox"/> Service	Vertriebsgebiet Nord Germany North <input checked="" type="checkbox"/> V/S <input type="checkbox"/> Service
INDRAMAT GmbH Bgm.-Dr.-Nebel-Str. 2 D - 97816 Lohr am Main Telefon: +49 (0)9352/40-0 Telefax: +49 (0)9352/40-4885	INDRAMAT GmbH Beckerstraße 31 D - 09120 Chemnitz Telefon: +49 (0)371/35 55-0 Telefax: +49 (0)371/35 55-333	INDRAMAT GmbH Harkortstraße 25 D - 40849 Ratingen Telefon: +49 (0)2102/43 18-0 Telefax: +49 (0)2102/41 315	INDRAMAT GmbH Kieler Straße 212 D - 22525 Hamburg Telefon: +49 (0)40/85 31 57-0 Telefax: +49 (0)40/85 31 57-15
Vertriebsgebiet Süd Germany South <input checked="" type="checkbox"/> V/S <input type="checkbox"/> Service	Gebiet Südwest Germany South-West <input checked="" type="checkbox"/> V/S <input checked="" type="checkbox"/> Service		INDRAMAT Service-Hotline INDRAMAT GmbH Telefon: +49 (0)172/660 04 06 oder Telefon: +49 (0)171/333 88 26
INDRAMAT GmbH Ridlerstraße 75 D-80339 München Telefon: +49 (0)89/540138-30 Telefax: +49 (0)89/540138-10	INDRAMAT GmbH Böblinger Straße 25 D-71229 Leonberg Telefon: +49 (0)7152/9 72-6 Telefax: +49 (0)7152/9 72-727		

Kundenbetreuungsstellen in Deutschland - Service agencies in Germany

Europa – Europe

vom Ausland: (0) nach Landeskennziffer weglassen,
from abroad: don't dial (0) after country code,

0 nach Landeskennziffer mitwählen!
dial 0 after country code!

Austria <input checked="" type="checkbox"/> V/S <input type="checkbox"/> Service Mannesmann Rexroth Ges.m.b.H. Geschäftsbereich INDRAMAT Hägelingasse 3 A - 1140 Wien Telefon: +43 (0)1/9852540-400 Telefax: +43 (0)1/9852540-93	Austria <input type="checkbox"/> V/S <input checked="" type="checkbox"/> Service Mannesmann Rexroth G.m.b.H. Geschäftsbereich INDRAMAT Industriepark 18 A - 4061 Pasching Telefon: +43 (0)7221/605-0 Telefax: +43 (0)7221/605-21	Belgium <input checked="" type="checkbox"/> V/S <input checked="" type="checkbox"/> Service Mannesmann Rexroth N.V.-S.A. Geschäftsbereich INDRAMAT Industrielaan 8 B-1740 Ternat Telefon: +32 (0)2/5823180 Telefax: +32 (0)2/5824310	Denmark <input checked="" type="checkbox"/> V/S <input checked="" type="checkbox"/> Service BEC AS Zinkvej 6 DK-8900 Randers Telefon: +45 (0)87/11 90 60 Telefax: +45 (0)87/11 90 61
England <input checked="" type="checkbox"/> V/S <input checked="" type="checkbox"/> Service Mannesmann Rexroth Ltd. INDRAMAT Division 4 Esland Place, Love Lane GB - Cirencester, Glos GL7 1YG Telefon: +44 (0)1285/658671 Telefax: +44 (0)1285/654991	Finland <input checked="" type="checkbox"/> V/S <input type="checkbox"/> Service Rexroth Mecman OY Ansatie 6 SF-017 40 Vantaa Telefon: +358 (0)9/84 91 11 Telefax: +358 (0)9/84 91 13 60	France <input checked="" type="checkbox"/> V/S <input checked="" type="checkbox"/> Service Mannesmann Rexroth S.A. Division INDRAMAT Parc des Barbanniers 4, Place du Village F-92632 Gennevilliers Cedex Telefon: +33 (0)141 47 54 30 Telefax: +33 (0)147 94 69 41 Hotline: +33 (0)6 08 33 43 28	France <input checked="" type="checkbox"/> V/S <input type="checkbox"/> Service Mannesmann Rexroth S.A. Division INDRAMAT 270, Avenue de Lardenne F - 31100 Toulouse Telefon: +33 (0)5 61 49 95 19 Telefax: +33 (0)5 61 31 00 41
France <input checked="" type="checkbox"/> V/S <input type="checkbox"/> Service Mannesmann Rexroth S.A. Divisione INDRAMAT 91, Bd. Irène Joliot-Curie F - 69634 Vénissieux - Cedex Telefon: +33 (0)4 78 78 53 65 Telefax: +33 (0)4 78 78 52 53	Italy <input checked="" type="checkbox"/> V/S <input checked="" type="checkbox"/> Service Mannesmann Rexroth S.p.A. Divisione INDRAMAT Via G. Di Vittoria, 1 I - 20063 Cernusco S/N.MI Telefon: +39 02/92 36 52 70 Telefax: +39 02/92 36 55 12	Italy <input checked="" type="checkbox"/> V/S <input checked="" type="checkbox"/> Service Mannesmann Rexroth S.p.A. Divisione INDRAMAT Via Borgomanero, 11 I - 10145 Torino Telefon: +39 011/7 71 22 30 Telefax: +39 011/7 71 01 90	Italy <input checked="" type="checkbox"/> V/S <input type="checkbox"/> Service Mannesmann Rexroth S.p.A. Divisione INDRAMAT Via del Progresso, 16 (Zona Ind.) I - 35020 Padova Telefon: +39 049/8 70 13 70 Telefax: +39 049/8 70 13 77
Italy <input type="checkbox"/> V/S <input checked="" type="checkbox"/> Service Mannesmann Rexroth S.p.A. Divisione INDRAMAT Via de Nicola, 12 I - 80053 Castellamare di Stabia NA Telefon: +39 081/8 72 30 37 Telefax: +39 081/8 72 30 18	Italy <input checked="" type="checkbox"/> V/S <input type="checkbox"/> Service Mannesmann Rexroth S.p.A. Divisione INDRAMAT Viale Oriani, 38/A I - 40137 Bologna Telefon: +39 051/34 14 14 Telefax: +39 051/34 14 22	Netherlands <input checked="" type="checkbox"/> V/S <input type="checkbox"/> Service Hydraudyne Hydrauliek B.V. Kruisbroeksestraat 1 P.O. Box 32 NL - 5281 RV Boxtel Telefon: +31 (0)411/65 19 51 Telefax: +31 (0)411/65 14 83 e-mail: indramat@hydraudyne.nl	Netherlands <input type="checkbox"/> V/S <input checked="" type="checkbox"/> Service Hydrocare B.V. Kruisbroeksestraat 1 P.O. Box 32 NL - 5281 RV Boxtel Telefon: +31 (0)411/65 19 51 Telefax: +31 (0)411/67 78 14
Poland <input checked="" type="checkbox"/> V/S <input type="checkbox"/> Service Mannesmann Rexroth Sp.zo.o. Biuro Poznan ul. Dabrowskiego 81/85 PL - 60-529 Poznan Telefon: +48 061/847 67 99 Telefax: +48 061/847 64 02	Spain <input checked="" type="checkbox"/> V/S <input checked="" type="checkbox"/> Service Mannesmann Rexroth S.A. DivisióN INDRAMAT Centro Industrial Santiga Obradors s/n E-08130 Santa Perpetua de Mogoda Barcelona Telefon: +34 937 47 94 00 Telefax: +34 937 47 94 01	Spain <input checked="" type="checkbox"/> V/S <input checked="" type="checkbox"/> Service Goimendi S.A. DivisióN Indramat Jolastokieta (Herrera) Apartado 11 37 E - 20017 San Sebastian Telefon: +34 9 43/40 01 63 Telefax: +34 9 43/39 17 99	Sweden <input checked="" type="checkbox"/> V/S <input checked="" type="checkbox"/> Service Rexroth Mecman Svenska AB INDRAMAT Division Varuvägen 7 S - 125 81 Stockholm Telefon: +46 (0)8/727 92 00 Telefax: +46 (0)8/64 73 277
Switzerland - East <input checked="" type="checkbox"/> V/S <input checked="" type="checkbox"/> Service Mannesmann Rexroth AG Geschäftsbereich INDRAMAT Gewerbstraße 3 CH-8500 Frauenfeld Telefon: +41 (0)52/720 21 00 Telefax: +41 (0)52/720 21 11	Switzerland - West <input checked="" type="checkbox"/> V/S <input type="checkbox"/> Service Mannesmann Rexroth SA Département INDRAMAT Chemin de l'Ecole 6 CH-1036 Sullens Telefon: +41 (0)21/731 43 77 Telefax: +41 (0)21/731 46 78	Russia <input type="checkbox"/> V/S <input checked="" type="checkbox"/> Service Tschudnenko E.B. Arsenia 22 RUS - 153000 Ivanovo Rußland Telefon: +7 093/223 96 33 oder/or +7 093/223 95 48 Telefax: +7 093/223 46 01	Slovenia <input checked="" type="checkbox"/> V/S <input checked="" type="checkbox"/> Service INDRAMAT elektromotorji d.o.o. Otoki 21 SLO - 64 228 Zelezniki Telefon: +386 64/61 73 32 Telefax: +386 64/64 71 50
Turkey <input checked="" type="checkbox"/> V/S <input checked="" type="checkbox"/> Service Mannesmann Rexroth Hidropar A..S. Fevzi Cakmak Cad No. 3 TR - 34630 Sefaköy Istanbul Telefon: +90 212/541 60 70 Telefax: +90 212/599 34 07			

Europäische Kundenbetreuungsstellen (ohne Deutschland)
European Service agencies (without Germany)

Außerhalb Europa - outside Europe

vom Ausland:
from abroad:

(0) nach Landeskennziffer weglassen!
don't dial (0) after country code!

<p>Argentina <input checked="" type="checkbox"/> V/S <input type="checkbox"/> Service</p> <p>Mannesmann Rexroth S.A.I.C. Division INDRAMAT Acassuso 48 41/7 RA - 1605 Munro (Buenos Aires)</p> <p>Telefon: +54 (0)1/756 01 40 +54 (0)1/756 01 36</p>	<p>Argentina <input checked="" type="checkbox"/> V/S <input checked="" type="checkbox"/> Service</p> <p>NAKASE Asesoramiento Tecnico Calle 49, No. 5764-66 RA - 1653 Villa Balester Provincia de Buenos Aires</p> <p>Telefon: +54 (0) 1/768 36 43 Telefax: +54 (0) 1/768 24 13 e-mail: nakase@usa.net nakase@infovia.com.ar</p>	<p>Australia <input checked="" type="checkbox"/> V/S <input checked="" type="checkbox"/> Service</p> <p>AIMS - Australian Industrial Machinery Services Pty. Ltd. Unit 3/45 Horne ST Campbellfield 3061 AUS - Melbourne, VIC</p> <p>Telefon: +61 (0)3/93 59 02 28 Telefax: +61 (0)3/93 59 02 86</p>	<p>Brazil <input checked="" type="checkbox"/> V/S <input checked="" type="checkbox"/> Service</p> <p>Mannesmann Rexroth Automação Ltda. Divisão INDRAMAT Rua Georg Rexroth, 609 Vila Padre Anchieta BR - 09951-270 Diadema-SP [Caixa Postal 377] [BR-09901-970 Diadema-SP]</p> <p>Telefon: +55 (0)11/745 90 60 +55 (0)11/745 90 70 Telefax: +55 (0)11/745 90 50</p>
<p>Brazil <input type="checkbox"/> V/S <input checked="" type="checkbox"/> Service</p> <p>Mannesmann Rexroth Automação Ltda. Divisão INDRAMAT Rua Umberto Pinheiro Vieira, 100 Distrito Industrial BR - 09220-390 Joinville - SC [Caixa Postal 1273]</p> <p>Tel./Fax: +55 (0)47/473 55 833 Mobil: +55 (0)47 974 6645 e-mail: prochnow@zaz.com.br</p>	<p>Canada <input checked="" type="checkbox"/> V/S <input checked="" type="checkbox"/> Service</p> <p>Basic Technologies Corporation Burlington Division 3426 Mainway Drive Burlington, Ontario Canada L7M 1A8</p> <p>Telefon: +1 905/335 55 11 Telefax: +1 905/335-41 84</p>	<p>China <input checked="" type="checkbox"/> V/S <input type="checkbox"/> Service</p> <p>Mannesmann Rexroth (China) Ltd. Shanghai Office - Room 206 Shanghai Internat. Trade Centre 2200 Yanan Xi Lu PRC - Shanghai 200335</p> <p>Telefon: +86 21/62 75 53 33 Telefax: +86 21/62 75 56 66</p>	<p>China <input type="checkbox"/> V/S <input checked="" type="checkbox"/> Service</p> <p>Mannesmann Rexroth (China) Ltd. Shanghai Parts & Service Center 199 Wu Cao Road, Hua Cao Minhang District PRC - Shanghai 201 103</p> <p>Telefon: +86 21/62 20 00 58 Telefax: +86 21/62 20 00 68</p>
<p>China <input checked="" type="checkbox"/> V/S <input type="checkbox"/> Service</p> <p>Mannesmann Rexroth (China) Ltd. 15/F China World Trade Center 1, Jianguomenwai Avenue PRC - Beijing 100004</p> <p>Telefon: +86 10/65 05 03 80 Telefax: +86 10/65 05 03 79</p>	<p>China <input checked="" type="checkbox"/> V/S <input type="checkbox"/> Service</p> <p>Mannesmann Rexroth (China) Ltd. A-5F., 123 Lian Shan Street Sha He Kou District PRC - Dalian 116 023</p> <p>Telefon: +86 411/46 78 930 Telefax: +86 411/46 78 932</p>	<p>Hongkong <input checked="" type="checkbox"/> V/S <input checked="" type="checkbox"/> Service</p> <p>Rexroth (China) Ltd. 19 Cheung Shun Street 1st Floor, Cheung Sha Wan, Kowloon, Hongkong</p> <p>Telefon: +852 22 62 51 00 Telefax: +852 27 41 33 44</p>	<p>India <input checked="" type="checkbox"/> V/S <input checked="" type="checkbox"/> Service</p> <p>Mannesmann Rexroth (India) Ltd. INDRAMAT Division Plot. 96, Phase III Peenya Industrial Area IND - Bangalore - 560058</p> <p>Telefon: +91 (0)80/8 39 21 01 Telefax: +91 (0)80/8 39 43 45</p>
<p>India <input checked="" type="checkbox"/> V/S <input checked="" type="checkbox"/> Service</p> <p>Mannesmann Rexroth (India) Ltd. INDRAMAT Division Plot. A-58, TTC Industrial Area Thane Turbhe Midc Road Mahape Village IND - Navi Mumbai - 400 701</p> <p>Telefon: +91 (0)22/7 61 46 22 Telefax: +91 (0)22/7 68 15 31</p>	<p>Indonesia <input checked="" type="checkbox"/> V/S <input type="checkbox"/> Service</p> <p>PT. Rexroth Wijayakusuma Jl. Raya Bekasi Km 21 Pulogadung RI - Jakarta Timur 13920</p> <p>Telefon: +62 21/4 61 04 87 +62 21/4 61 04 88 Telefax: +62 21/4 60 01 52</p>	<p>Japan <input checked="" type="checkbox"/> V/S <input checked="" type="checkbox"/> Service</p> <p>Rexroth Automation Co., Ltd. INDRAMAT Division 1F, I.R. Building Nakamachidai 4-26-44 Tsuzuki-ku, YOKOHAMA 224-0041 Japan</p> <p>Telefon: +81 459/42-72 10 Telefax: +81 459/42-03 41</p>	<p>Japan <input checked="" type="checkbox"/> V/S <input checked="" type="checkbox"/> Service</p> <p>Rexroth Automation Co., Ltd. INDRAMAT Division Yutakagaoka 1810 Meito-ku, NAGOYA 465-0035 Japan</p> <p>Telefon: +81 (0)52/777 88 41 +81 (0)52/777 88 53 +81 (0)52/777 88 79 Telefax: +81 (0)52/777 89 01</p>
<p>Mexico <input checked="" type="checkbox"/> V/S <input type="checkbox"/> Service</p> <p>Rexroth Mexico S.A. de C.V. Calle Neptuno 72 Unidad Ind. Vallejo MEX - 07700 Mexico, D.F.</p> <p>Telefon: +52 5 754 17 11 +52 5 754 36 84 +52 5 754 12 60 Telefax: +52 5 754 50 73 +52 5 752 59 43</p>	<p>Korea <input checked="" type="checkbox"/> V/S <input checked="" type="checkbox"/> Service</p> <p>Mannesmann Rexroth-Seki Co Ltd. 1500-12 Da-Dae-Dong ROK - Saha-Ku, Pusan, 604-050</p> <p>Telefon: +82 (0)51/2 60 06 18 Telefax: +82 (0)51/2 60 06 19</p>	<p>Korea <input checked="" type="checkbox"/> V/S <input checked="" type="checkbox"/> Service</p> <p>Seo Chang Corporation Ltd. Room 903, Jail Building 44-35 Yeouido-Dong Yeoungdeungpo-Ku C.P.O.Box 97 56 ROK - Seoul</p> <p>Telefon: +82 (0)2/7 80 82 08 +82 (0)2/7 80 82 09 Telefax: +82 (0)2/7 84 54 08</p>	<p>South Africa <input checked="" type="checkbox"/> V/S <input checked="" type="checkbox"/> Service</p> <p>HYTEC Automation (Pty) Ltd. 28 Banfield Road, Industria North RSA - Maraisburg 1700</p> <p>Telefon: +27 (0)11/673 20 80 Telefax: +27 (0)11/673 72 69</p>
<p>Taiwan <input checked="" type="checkbox"/> V/S <input type="checkbox"/> Service</p> <p>Rexroth Uchida Co., Ltd. No.1, Tsu Chiang Street Tu Cheng Ind. Estate Taipei Hsien, Taiwan, R.O.C.</p> <p>Telefon: +886 2/2 68 13 47 Telefax: +886 2/2 68 53 88</p>			

Kundenbetreuungsstellen außerhalb Europa - Service agencies outside Europe

Außerhalb Europa / USA - outside Europe / USA

USA <input checked="" type="checkbox"/> V/S <input checked="" type="checkbox"/> Service Mannesmann Rexroth Corporation INDRAMAT Division 5150 Prairie Stone Parkway USA - Hoffman Estates, IL 60192-3707 Telefon: +1 847/6 45 36 00 Telefax: +1 847/6 45 62 01	USA <input checked="" type="checkbox"/> V/S <input checked="" type="checkbox"/> Service Mannesmann Rexroth Corporation INDRAMAT Division Central Region Technical Center USA - Auburn Hills, MI 48326 Telefon: +1 248/3 93 33 30 Telefax: +1 248/3 93 29 06	USA <input checked="" type="checkbox"/> V/S <input checked="" type="checkbox"/> Service Mannesmann Rexroth Corporation INDRAMAT Division Southeastern Technical Center 3625 Swiftwater Park Drive USA - Suwanee Georgia 30174 Telefon: +1 770/9 32 32 00 +1 770/9 32 19 03	USA <input checked="" type="checkbox"/> V/S <input checked="" type="checkbox"/> Service Mannesmann Rexroth Corporation INDRAMAT Division Northeastern Technical Center 99 Rainbow Road USA - East Granby, Connecticut 06026 Telefon: +1 860/8 44 83 77 +1 860/8 44 85 95
USA <input checked="" type="checkbox"/> V/S <input checked="" type="checkbox"/> Service Mannesmann Rexroth Corporation INDRAMAT Division Charlotte Regional Sales Office 14001 South Lakes Drive USA - Charlotte, North Carolina 28273 Telefon: +1 704/5 83 97 62 +1 704/5 83 14 86			

Kundenbetreuungsstellen außerhalb Europa / USA
 Service agencies outside Europe / USA

NOTICE

