

## A02B-0200-C901 - Heat Exchanger

### General

|               |                |
|---------------|----------------|
| Specification | A02B-0200-C901 |
| Description   | Heat Exchanger |
| Weight [kg]   | 4.06           |

### Outline Dimensions

#### Heat Pipe Type Heat Exchanger (CE Mark) - Specification

| Installation format |                        | Installation type in board |      |
|---------------------|------------------------|----------------------------|------|
| Fan specifications  | Coolign ability (W/°C) | 9                          |      |
|                     | Voltage (V)            | 200VAC                     |      |
|                     | Frequency (Hz)         | 50                         | 60   |
|                     | Rating current (A)     | 0.28                       | 0.24 |
|                     | Rating input (W)       | 28                         | 26   |
| Weight (kg)         |                        | 4                          |      |
| Color               |                        | Munsell signal N1.5        |      |

CE marking-compatible heat exchanger A02B-0200-C901

#### Heat Pipe Type Heat Exchanger (CE Mark) - Specification

## Outline Dimensions

### Heat Pipe Type Heat Exchanger (CE Mark) - Outline Drawing

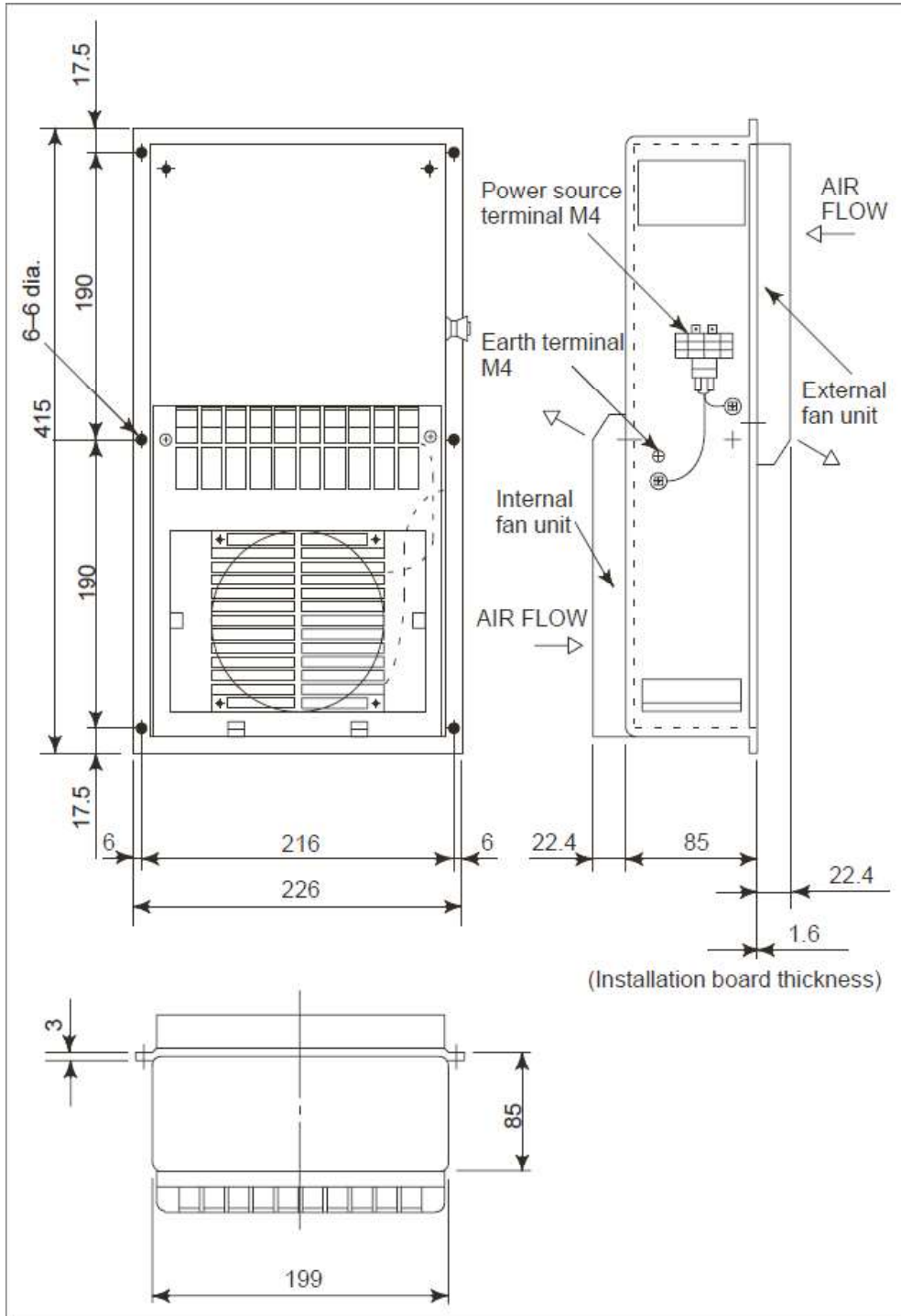

Heat Pipe Type Heat Exchanger (CE Mark) - Outline Drawing

## Outline Dimensions

### Heat Pipe Type Heat Exchanger (CE Mark) - Panel Cut

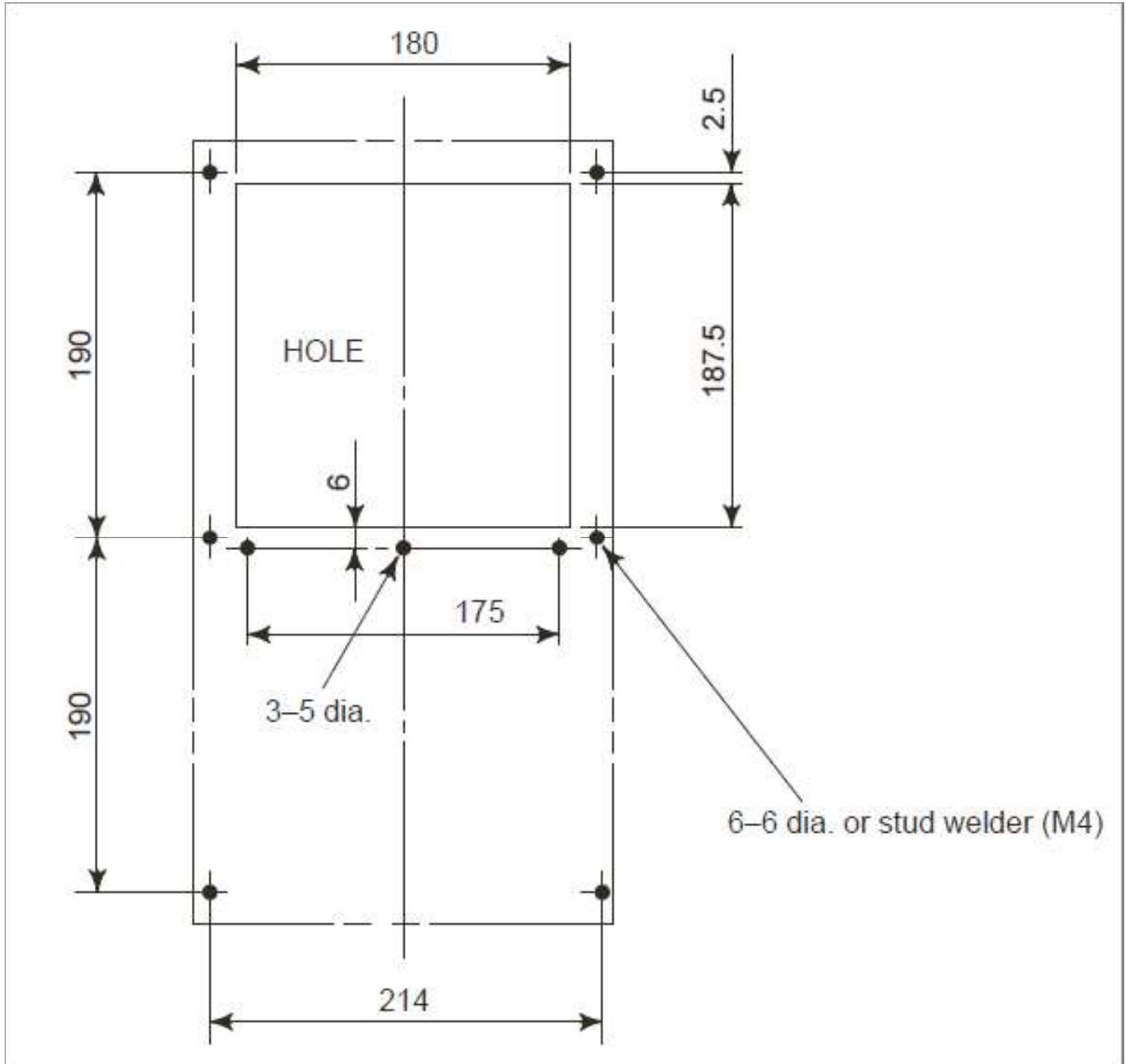

*Heat Pipe Type Heat Exchanger (CE Mark) - Panel Cut*