



Technical Manual

MDL450 LED module light white-diffuse

Article-No.: 08K0011A

Version: 1.5

© Vision Tools Bildanalyse Systeme GmbH
Heinrich-Hertz-Straße 7
68753 Waghäusel
Germany

Tel.: +49 7254 – 9351 0
Fax: +49 7254 – 9351 200

www.vision-tools.com
info@vision-tools.com

Revision date:	April 2019
Version:	1.5
Version change:	Attachment, Technical data

1 Table of contents

1	Table of contents	1
2	General	2
2.1	Abbreviations	2
2.2	Information on the manual	2
2.3	Documents enclosed	2
2.4	Safety information	2
2.5	Limitation of liability	4
2.6	Copyright law	4
2.7	Guarantee and Liability	4
3	Safety	5
3.1	Appropriate use	5
3.2	Foreseeable misuse	5
4	Technical Data.....	6
4.1	Dimensions (mm).....	7
4.2	Pin Assignment.....	7
4.3	Settings	7
5	Commissioning	8
5.1	Initial operation	8
5.2	Return to service.....	8
5.3	Assembly	9
6	Maintenance and repair	10
6.1	Recommended Spare Parts	10
7	Product versions.....	10
8	Disposal.....	11
9	Notes	12
10	Attachment	13
10.1	Declaration of conformity	13

2 General

2.1 Abbreviations

The abbreviations used are explained below:

- V60 = image analysis program from the VisionTools company
- PPE = personal protective equipment
- I/O = input/output
- MDL = module light

2.2 Information on the manual

This technical manual contains important instructions for working with the product named on the cover sheet. The prerequisite for workplace safety is the observance of all safety and handling instructions specified in this manual. The local accident prevention regulations and national health and safety regulations must be observed in addition to the instructions in this manual. All information and instructions are to be carefully read before use. The manual is a product component and must be kept accessible to the plant operator at all times.

2.3 Documents enclosed

- Declaration of Conformity

2.4 Safety information

In this manual, icons (acc. to EN ISO 7010) are used to highlight correct text passages and relevant sections. If the product is sold in a non-EU country, the warning symbols may need to be amended, if necessary.

The signal word describes the severity of the impending risks:

- **Danger!** Imminent dangerous situation which will result in serious bodily injury or death.
- **Warning!** Potentially dangerous situation which could result in serious bodily injury or death.
- **Caution!** Potentially dangerous situation which could result in minor bodily injury or death. Also warning of damage to property.
- **Note!** For application instructions and other important information.



Note

General information



Follow the instructions

In accordance with DIN EN ISO 7010



General warning sign

In accordance with DIN EN ISO 7010



Warning of electrical voltage

In accordance with DIN EN ISO 7010



Warning of hot surface

In accordance with DIN EN ISO 7010



Warning of oxidising substances

In accordance with DIN EN ISO 7010

2.5 Limitation of liability

All information and statements in this manual are compiled in consideration of valid standards and regulations, as well as state of the art technological knowledge.

The manufacturer accepts no liability for damages due to:

- Failure to observe this manual
- Inappropriate use
- Using non-trained personnel
- Undertaking unauthorized modifications
- Using impermissible replacement parts

Additionally, the obligations, the General Terms and Conditions and delivery conditions of the manufacturer, and the statutory regulations valid at the time the contract was concluded will apply.

2.6 Copyright law

Copyright law to this operating manual belongs to the company VisionTools Bildanalyse Systeme GmbH. This manual is intended only for the operator and the operator's personnel.

It includes regulations and information that may not be

- duplicated,
- distributed, or
- transmitted in any other manner, either in whole or in part.

Duplicating the manual within a company for the purposes of training by the operator is excepted. Violations may have criminal consequences.

2.7 Guarantee and Liability

Our General Terms and Conditions apply. Claims for a guarantee or for liability in case of personal injury or property damage are excluded if they are due to one or more of the following causes.

- Inappropriate use of the assembly
- Inappropriate installation, commissioning, operation, and maintenance of the device or system
- Failure to follow the information in the manual regarding transportation, storage, installation, commissioning, operation, limit values, maintenance of assemblies
- Unauthorized modifications to the assemblies
- Unauthorized modifications to the programmes
- Lack of monitoring of components subject to wear
- Catastrophic incidents due to foreign objects and force majeure
- Liability for subsequent damages is excluded

3 Safety

3.1 Appropriate use

The best possible contrast is needed for various tests with V60. In order to produce a good contrast, the desired location is illuminated by one or more MDLs.

3.2 Foreseeable misuse

Any other use besides that determined in Appropriate use this chapter or any use extending beyond this is **not** appropriate!

The operator will bear sole responsibility

- for any damages that may result from such use.
- the company VisionTools accepts no liability.

In case of changes or unauthorized modifications to the system, any liability or guarantee from VisionTools Bildanalyse Systeme GmbH will cease to exist.

The electromagnetic behaviour of the system can be impaired by additions or changes of any kind.

Therefore, make **no** changes or additions to the system without consulting with the company VisionTools Bildanalyse Systeme GmbH and receiving written approval to do so.



Danger!

Dangers may occur following improper use.

4 Technical Data

Designation	Min.	Typ.	Max.	Unit
Type of glass		diffuse		
Wavelength		5500 (White)		K
Number LEDs		36		
Lumen per LED		81		lm
Lumen Typ.		2916		lm
Operating voltage	22	24	30	V
Operating current	1,32	1,62	1,74	A
Power consumption		39		W
Dimming external		0 – 10		V
Dimming internal		0 – 100		%
Dimming fix		95		%
Trigger external		10 – 30		V
Trigger Current		approx. 6		mA
Perm. ambient temperature		-10 – 50		°C
Protection type		IP40		
Mean time between failures(MTBF)		100000		h
Life span typ.		max. 50000		h
Luminous efficiency after 100h		98		%
Luminous efficiency after 50000h		95		%
Luminous efficiency after 100000h		90		%
Connection		M12 Male- Connector 4pin A- Coded		
Weight		approx. 3300		g
Light area		450 x 120		mm

4.1 Dimensions (mm)

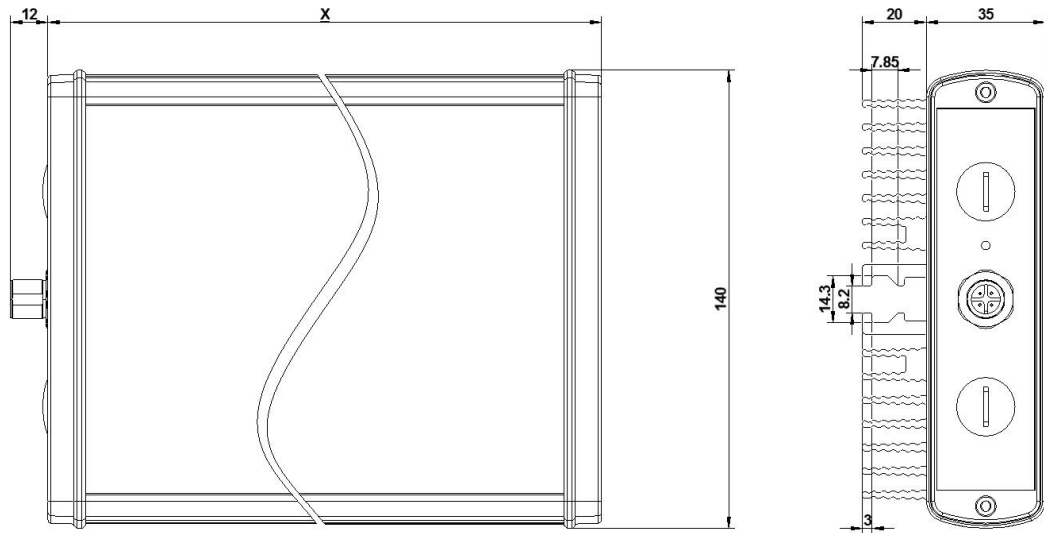

X = 470

4.2 Pin Assignment

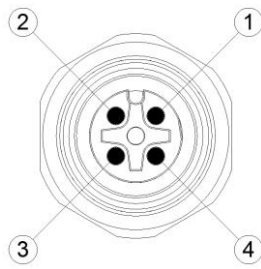

M12 Male-Connector 4pin
A-Coded

Pin	Signal	Colour of Conductor
1	+24 VDC	brown
2	—	white
3	0 V (GND)	blue
4	EXT	black

4.3 Settings

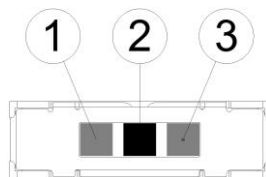

Switch Position	Setting (MODE)
1	internal dimming (Poti)
2	luminosity fix
3	external control

5 Commissioning

5.1 Initial operation

Specifically, the following points should be noted:

- The specified operating voltage of the MDL (The operating voltage can be found in chapter Technical Data)
- The MDL glows continuously because the slider is in the delivery status is at the second position. (see Settings)

5.2 Return to service

Specifically, the following points should be noted:

- The setting of the slide switch (see Settings)
- If necessary, the surface of the MDL should be cleaned with a dry cloth to eliminate dust and other dirt.

5.3 Assembly

On the back of the MDL, either a flange clamping piece (for mounting to round tubes 18x1.5mm) or an aluminium joint (for mounting on item profiles) can be mounted with the help of slot nuts. In order to rotate an MDL with a flange clamping piece by 90°, it is advisable to install a dedicated adapter plate between the MDL and the flange clamping piece.

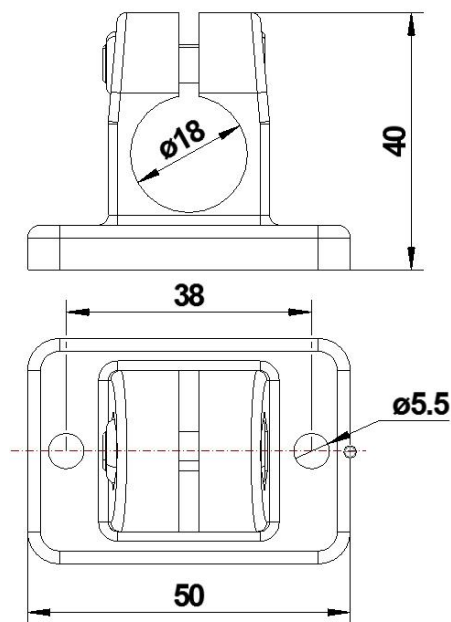

Fig.:1 Flange clamping piece FK18

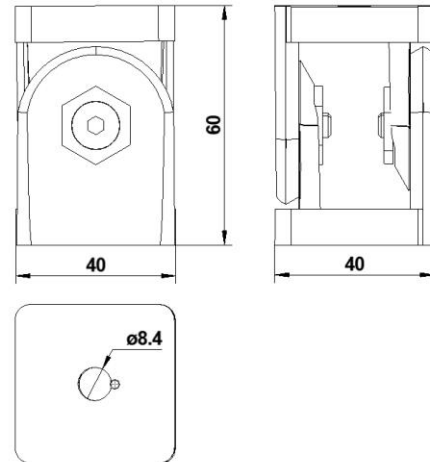

Fig.:2 Aluminium joint 8 40x40

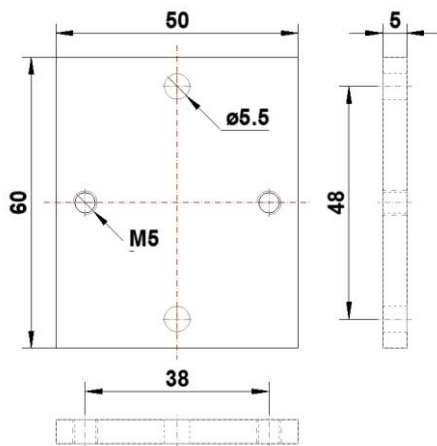

Fig.:3 Adapter plate 90° for FK18



NOTE!

It is recommended that for MDLs with sizes larger than 300mm, either **two** flange clamping pieces or **two** aluminium joints should be installed!

6 Maintenance and repair



NOTE!

To ensure a consistent lighting, unwanted dirt should be wiped off the module lamp with a dry cloth at regular intervals. The frequency of such checks depends on the cleanliness of the environment.

6.1 Recommended Spare Parts

Article-no.	Product
08K0903G	replacement lens MDL450 diffuse
10B0006A	Alu-joint 8 40x40
10A0008A	Flange clamp FK 18
10A0008B	Flange clamp FK 18 with elongated hole
08K0101A	Adapter plate 90° for FK18
09E0003B	Power cabel M12 4pos. female-connector 5m open end
09E0003C	Power cabel M12 4pos. female-connector 10m open end
09E0003E	Power cabel M12 4pos. female-connector 15m open end
09E0003D	Power cabel M12 4pos. female-connector 20m open end
09E0003F	Power cabel M12 4pos. female-connector 25m open end

7 Product versions

The following versions of the MDL are available for linking:

MDL sizes (mm)	Colours	Replacement lenses	Diffusing lenses	Special
<ul style="list-style-type: none"> • 75 • 150 • 300 • 450 • 600 	<ul style="list-style-type: none"> • Red • White • Blue 	<ul style="list-style-type: none"> • Diffuse • Clear 	<ul style="list-style-type: none"> • 10° • 25° 	<ul style="list-style-type: none"> • Infra-red

8

Disposal

Dispose special waste and garbage according to internal provisions and regulations. These must be brought to the correct collection stations.

Your responsible administrative authority can give you more specific information on where authorized collection stations can be found.



NOTE!

Observe national regulations and internal operational solutions!

Dispose of the packaging of production materials (including in the product cycle of the system) appropriately!

Ensure appropriate separation and disposal.

9 Notes

10 Attachment

10.1 Declaration of conformity



EG-Konformitätserklärung

Original

Hersteller:

Firmenname: VisionTools
Bildanalyse Systeme GmbH
Straße: Goethestraße 63
Ort: 68753 Waghäusel
Land: Deutschland

Bevollmächtigte Person,
für die Zusammenstellung der technischen
Unterlagen:

Name: Josef Djulic
Funktion: Geschäftsführer

Produkte:

„Modulleuchten“

Artikel-Nr.:

08K0001A, 08K0001B, 08K0001C, 08K0002A, 08K0002B, 08K0002C, 08K0003A, 08K0003B,
08K0003C, 08K0004A, 08K0004B, 08K0004C, 08K0005A, 08K0005B, 08K0005C, 08K0006A,
08K0006B, 08K0006C, 08K0007A, 08K0007B, 08K0007C, 08K0008A, 08K0008B, 08K0008C,
08K0009A, 08K0009B, 08K0009C, 08K0011A, 08K0011B, 08K0011C, 08K0017C

Hiermit erklären wir, dass die bezeichneten Produkte aufgrund ihrer Konzipierung und Bauart in der von uns in Verkehr gebrachten Ausführung den grundlegenden Sicherheits- und Gesundheitsanforderungen der nachfolgend aufgeführten EG-Richtlinien entsprechen.

Angewandte Richtlinien:

- EMV-Richtlinie 2014/30/EU

Angewandte harmonisierte Normen:

- DIN EN 61000-6-2; VDE 0839-6-2:2006-03
Elektromagnetische Verträglichkeit (EMV) - Störfestigkeit für Industriebereiche
- DIN EN 61000-6-4; VDE 0839-6-4:2011-09
Elektromagnetische Verträglichkeit (EMV) - Störaussendung für Industriebereiche

Hinweis:

Die Produkte sind keine Maschinen im Sinne der Maschinenrichtlinie.

Waghäusel, den 05.08.2016

Vorname, Name

